

Lavabo rigole en inox type mural pour 2 personnes , avec plaque anti-éclaboussures , équipé de tuyauteries prémontées et de robinets eau froide

1200 mm x 490 mm x 430 mm

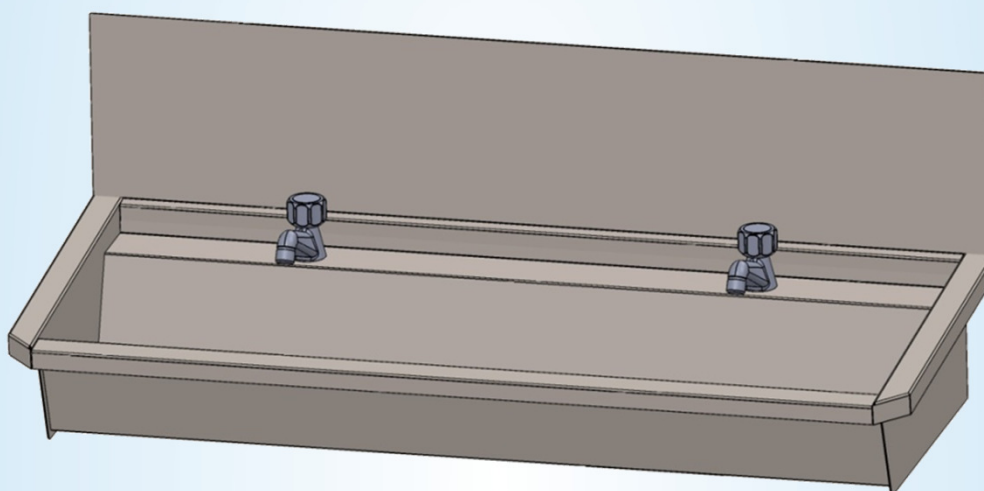

3.0-2-L1

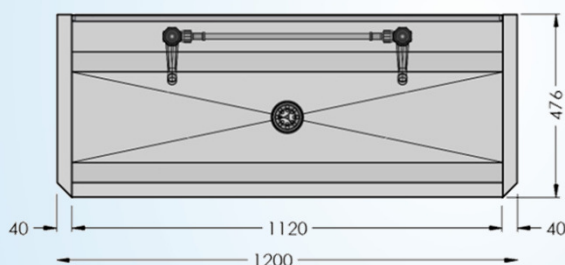
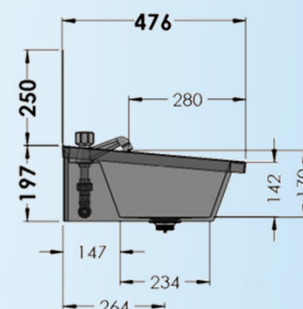
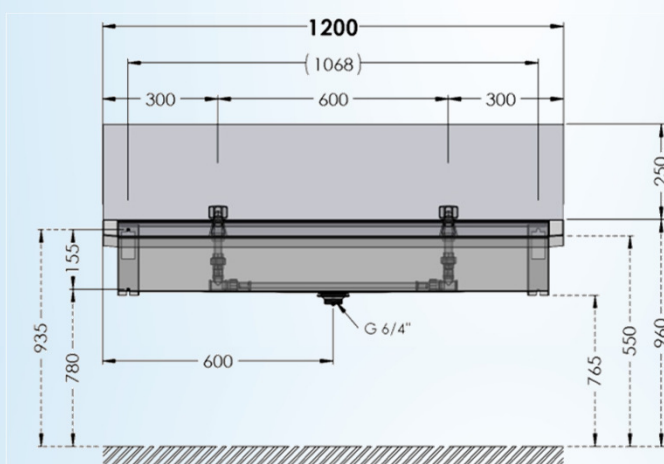

Information logistique :

poids:
1 colli

netto: 15,11 kg

bruto: 17,11 kg

Sanilav®

Fiche Technique

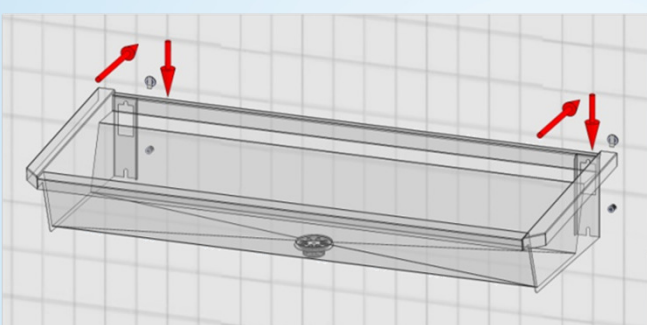
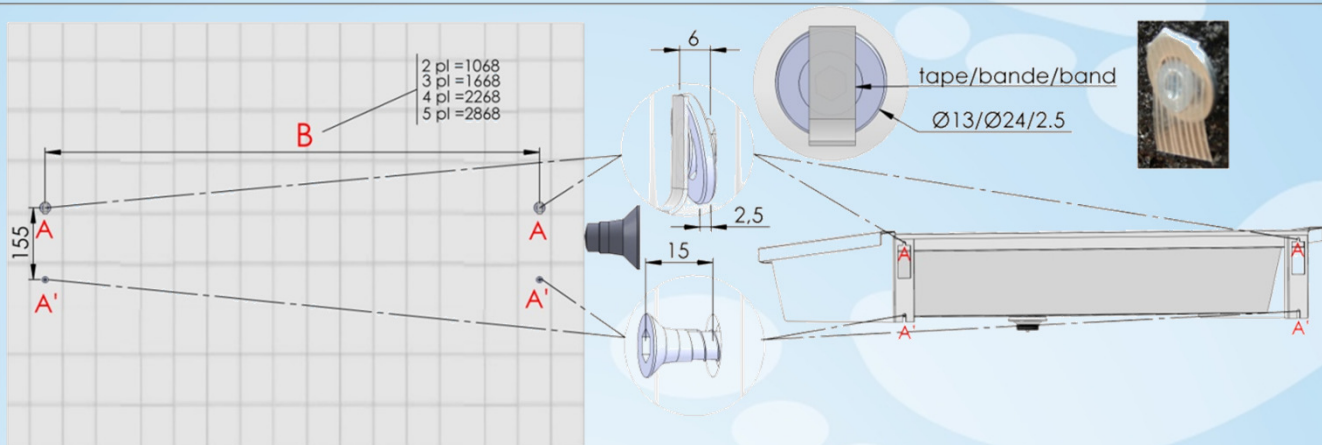

Bevestigingsgaten - I trous de fixation
 Fixation – Befestigung

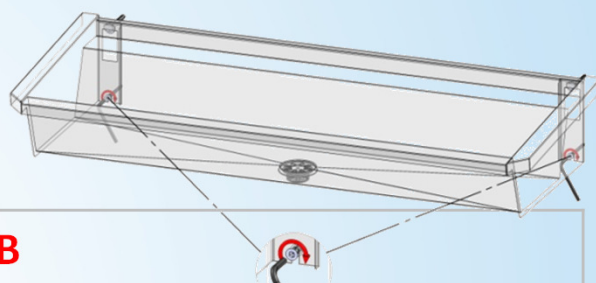

B Na te meten – A mesurer
 To measure - Nachmessen

Aansluitingschema – Instructions de raccordement Water connection Instructions – Wasseranschluss Anleitung

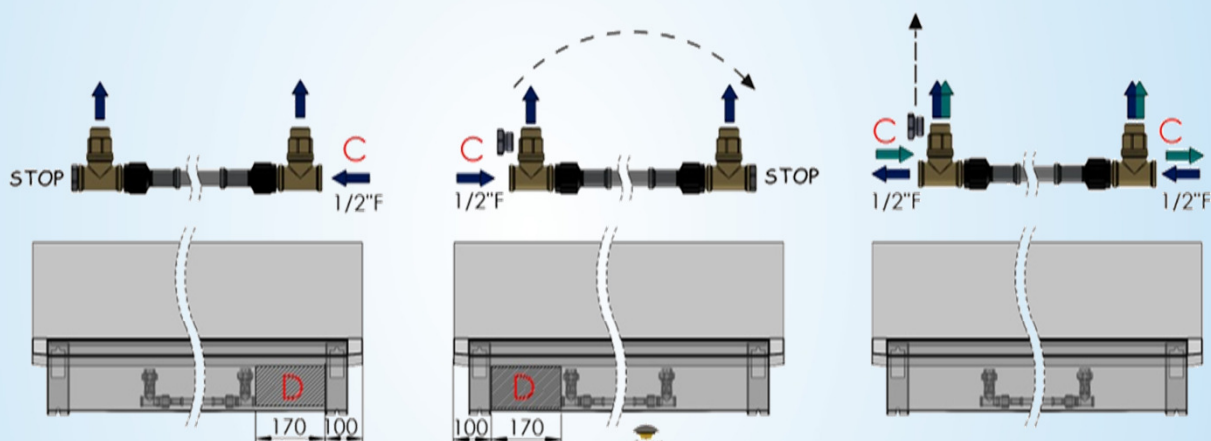

D : ZONE WATERAANSLUITING / ZONE RACCORDEMENT D'EAU / WATERCONNECTION ZONE / WASSERANSCHLUSSZONE

Intersan adviseert om een filter te monteren vóór de wateraansluiting (C) van elke wasgoot .
 Intersan conseille à monter un filtre avant le raccordement d'eau (C) de chaque lavabo rigole .
 Intersan advises to install a filter before the water connection (C) of every wash trough .
 Intersan empfiehlt einen Filter zu installieren vor jedem Wasseranschluss (C) jeder Waschrinnen .