

PIVOT DOOR & LUXURY PIVOT DOOR

SUPREME

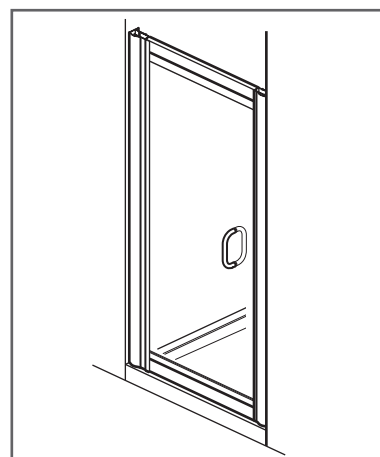

LUXURY PIVOT DOOR

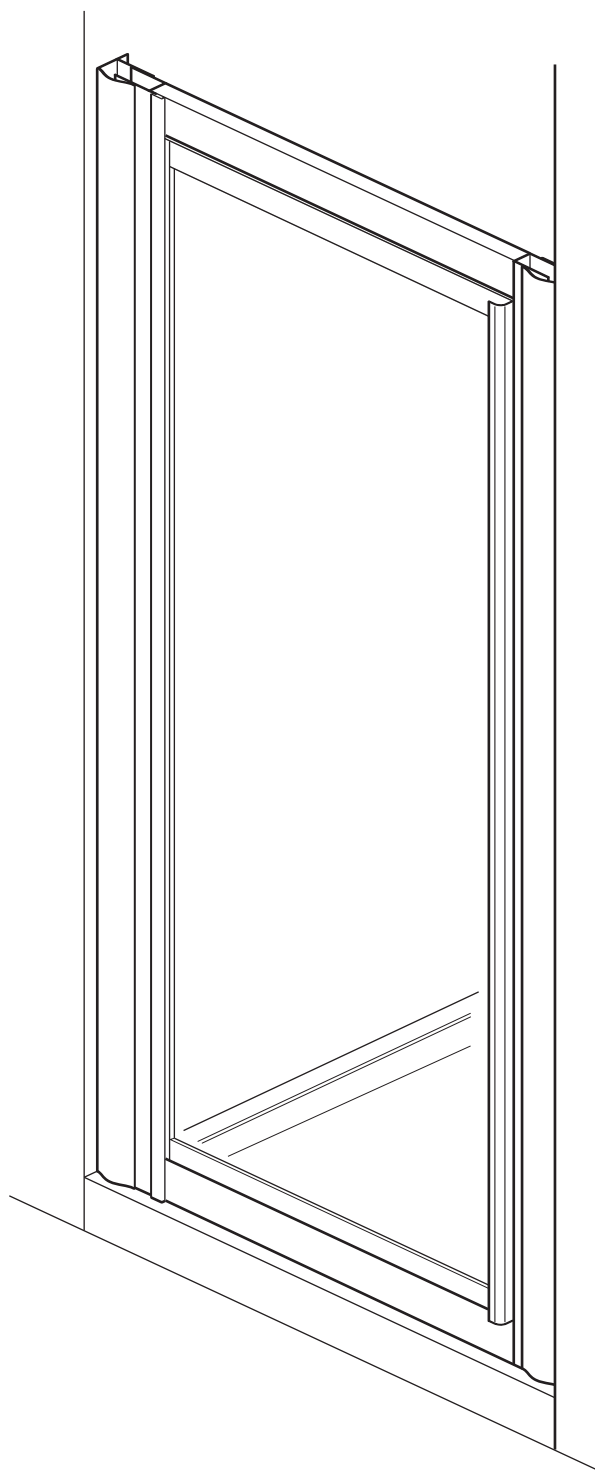
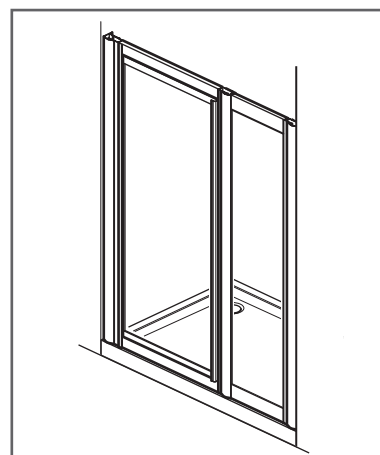

PIVOT DOOR & INLINE PANEL

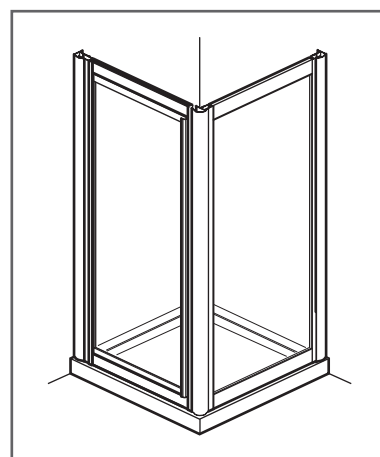

PIVOT DOOR & SIDE PANEL

INSTALLATION INSTRUCTIONS

simpsons 

IMPORTANT - Please read before installation

Please read these instructions carefully before starting installation and keep in a safe place for future reference.

Check the contents of the pack carefully before installation. Simpsons will not be held responsible for any de-ft / re-ft costs where faulty product has been fitted.

If any fault is found with materials or workmanship, it must be reported immediately to the manufacturer. Remedial action will be taken, based on information received, on condition that: 1. Full details are supplied to the manufacturer; 2. The enclosure has not been modified or tampered with; 3. The manufacturer is informed of any damage/shortages prior to installation.

We do not accept responsibility for any problems that may occur through incorrect installation.

The success of the installation and operation of any shower enclosure is, of course, dependant on the squareness, alignment and construction of the walls to which fixing is to be carried out.

VERY IMPORTANT

You must complete all tiling and grouting, and the shower tray **MUST** be level and fully sealed to the tiles before installation. If you do not fit the enclosure onto a tiled surface, or seal the tiles to the tray before installation, water may soak into the wall behind the wall channels.

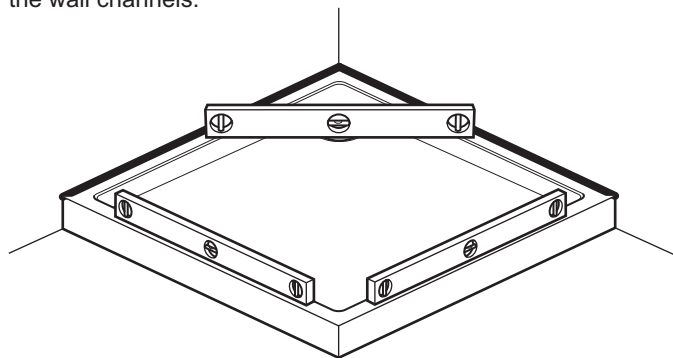

INSTALLATION - Advice and safety

All Supreme shower doors and panels are fully assembled and are reversible for left or right hand fitting, simply turn the door or panel up side down.

The Supreme doors come with the two wall channels pushed onto each side of the door frame. The side panels and inline panels do **NOT** come with wall channels, you must use one of the channels from the door.

The installation instructions are based on typical use and conditions.

The pivot doors are designed to open outwards only.

Please follow the installation instructions relevant to your enclosure.

These hints have been prepared for your guidance, you must exercise due care at all times.

It is recommended that 2 people carry out the installation of this enclosure.

Handle glass with care. Although the glass supplied is toughened

safety glass (to EN12150), impacts can damage both the glass and the frame.

Warning! Please check for any hidden pipes or cables before drilling holes in the wall.

To stop the drill bit slipping, masking tape can be applied to the tiles when preparing the holes.

When using power tools always follow the manufacturers user instructions.

Do not sit the enclosure on a bed of silicone, as this will also stop any water from draining back into the tray.

DO NOT SEAL THE ENCLOSURE TO THE TRAY ON THE INSIDE

If the enclosure is sealed to the tray on the inside, any water that may get into the framework will not be able to drain back into the tray, this may cause the enclosure to leak.

Leave the silicone sealant to dry for 24 hours before using the enclosure.

CARE AND CLEANING

Do not use solvents or abrasive materials or chemicals to clean the enclosure.

Only clean using soapy water and a soft cloth, rinse thoroughly afterwards.

CONTENTS

DOOR IN ALCOVE

See pages 3 - 5

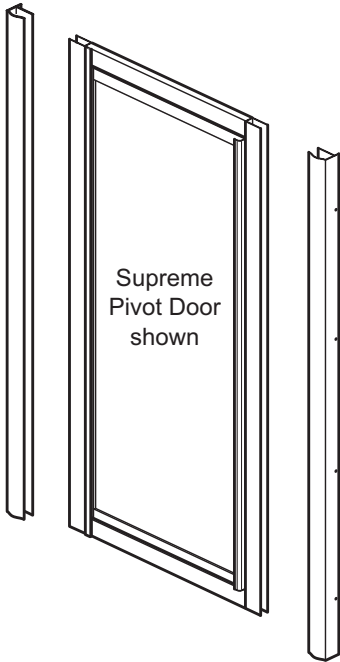

A  10mm Screw x 6

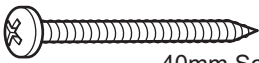
B  40mm Screw x 8

C  Wall plug x 8

D  Screw cover x 14

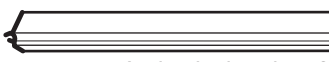
E  Anti splash strip x 2

WITH LUXURY PIVOT DOOR ONLY

F  Door handle x 1

DOOR & INLINE PANEL

See pages 6 - 9

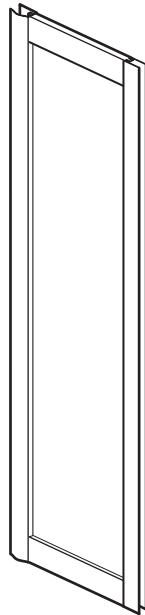

A  10mm Screw x 3

D  Screw cover x 3

G  Brace bar x 1

H  16mm Screw x 2

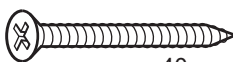
I  40mm Screw x 1

C  Wall plug x 1

DOOR & SIDE PANEL

See pages 10 - 11

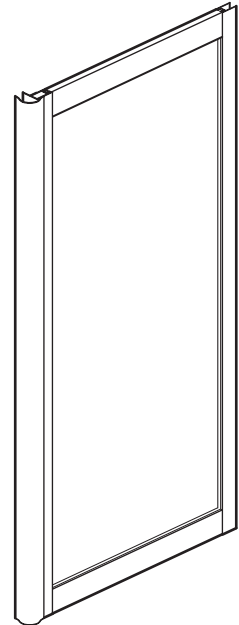

A  10mm Screw x 6

D  Screw cover x 6

RECOMMENDED WHEN 2 SIDE PANELS ARE USED

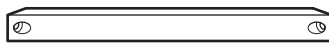
G  Brace bar x 2

H  16mm Screw x 4

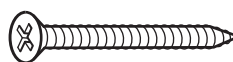
I  40mm Screw x 2

C  Wall plug x 2

Tools and equipment needed

Drill, 6.5mm Masonry drill bit, 3.2mm General drill bit, Phillips screwdriver, Spirit level, Pencil, Scissors, Silicone sealant.

PIVOT DOOR IN ALCOVE

Step 1

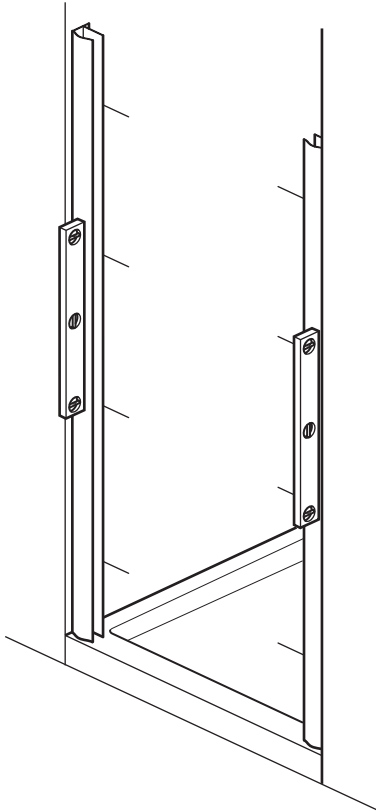

Remove both wall channels from the door frame. Place each wall channel in position on the tray (10 - 15mm in from the outer edge of the tray), use a spirit level to ensure they are vertical and mark all 8 fixing holes onto the walls (holes inside).

Drill holes in the positions marked using a 6.5mm masonry drill bit. Insert wall plugs (C) into all of the holes (beyond the thickness of the tile).

On pivot side only: Fix the wall channel to the wall using 4 x 40mm screws (B) and push on the screw covers (D).

Note: Inject silicone sealant into the holes before inserting the screws to seal the holes.

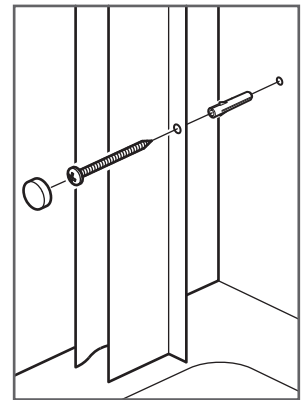
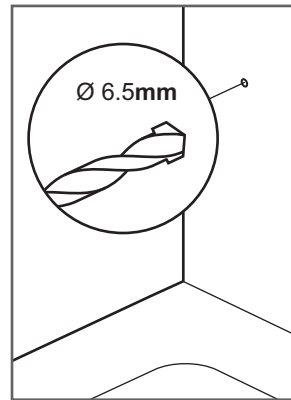
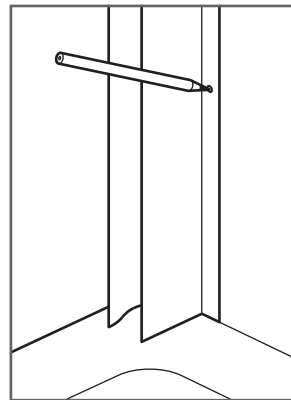

Option

Luxury pivot door only:

Fit the door handle (F) with the grub screws under the outside handle. First dismantle the handle using the hexagonal key supplied. Attach the inner handle tightening the screws (*) onto the door. Re-attach the outer handle as shown.

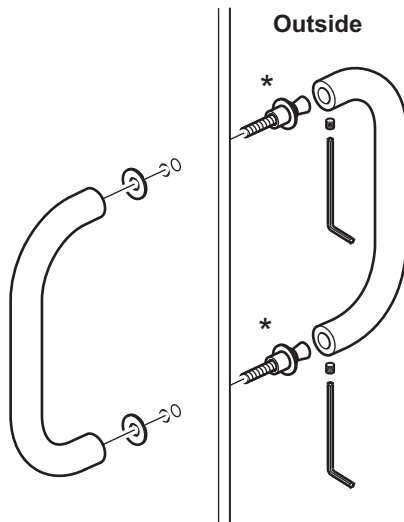

Step 2

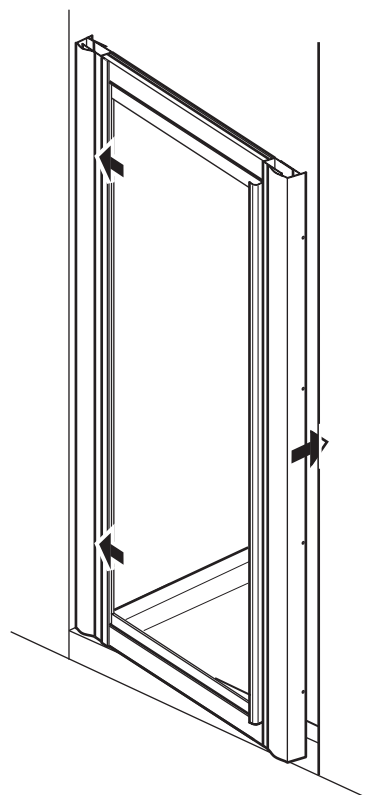

Push the remaining wall channel back onto the door frame on the opening/handle side of the door.

Insert the door into the 'fixed' wall channel and swing the free end into position on the opposite wall. Line up the fixing holes on the second wall channel with those on the wall and fix using 4 x 40mm screws (B) and push on the screw covers (D). **Note:** Inject silicone sealant into the holes before inserting the screws to seal the holes.

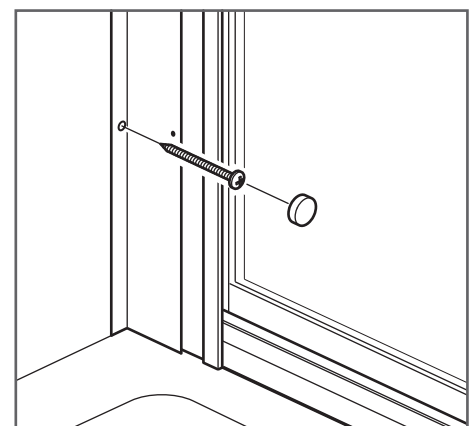

PIVOT DOOR IN ALCOVE

Step 3

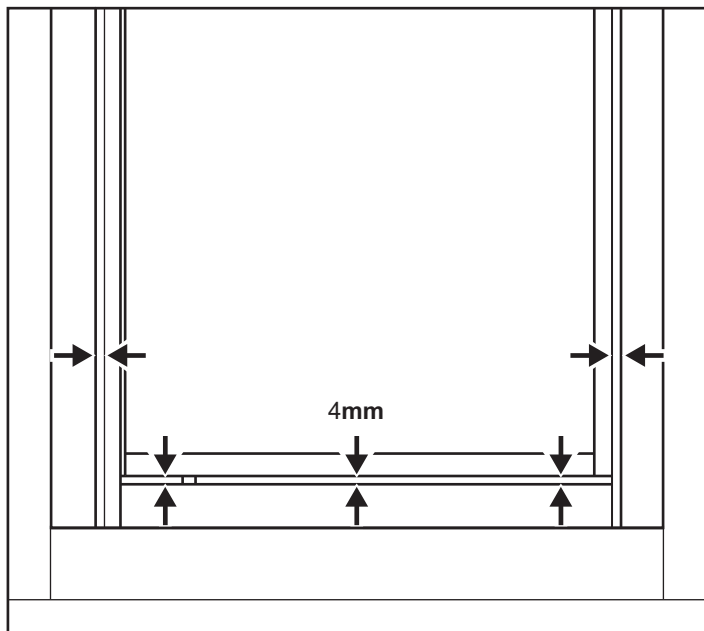

Before fixing the door to the wall channels you must make sure that the door is square within its outer frame.

First, centre the door frame between the wall channels. Next, with the door closed the 4mm gap between the bottom of the door and the frame **MUST** be parallel all the way across. If the gap is not parallel, push the top of the door frame to the left or right so the door hangs squarely within its outer frame.

Step 4

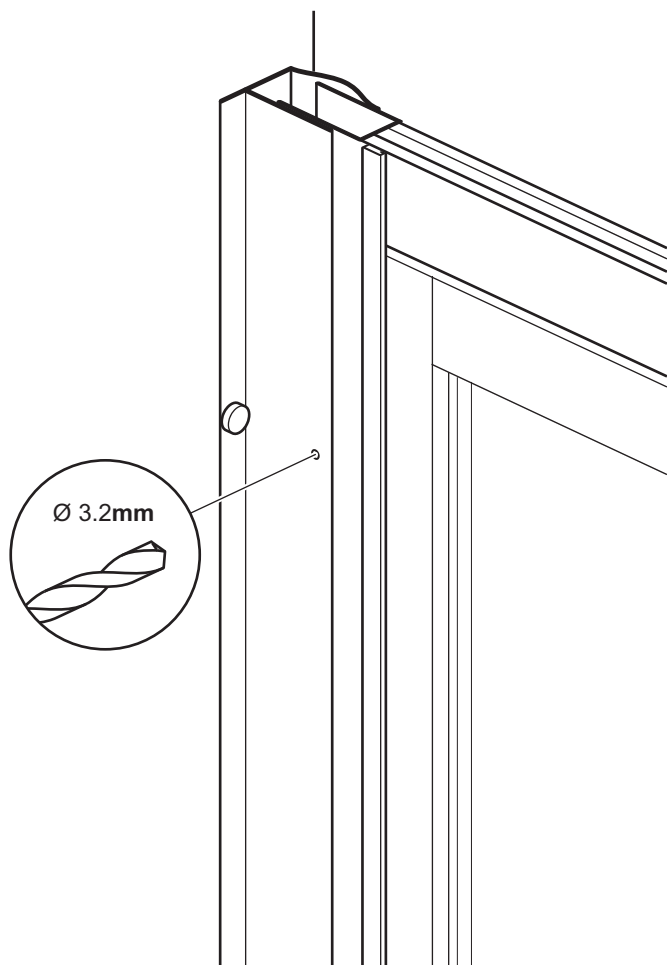

Once you have checked that the door opens and closes correctly fix the door to the wall channels.

From inside, drill 3 holes through each wall channel (in the marked positions) into the door frame using a 3.2mm drill bit. Fix using 6 x 10mm screws (A) and push on the screw covers (D).

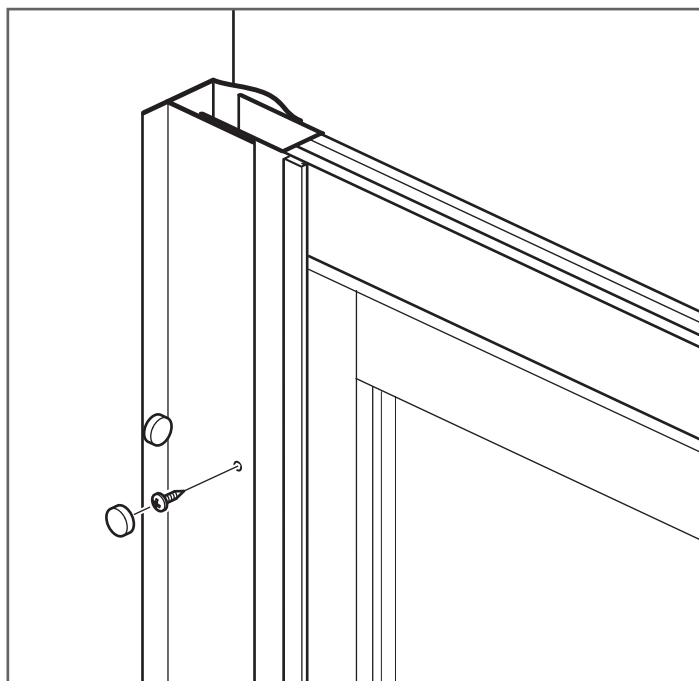

PIVOT DOOR IN ALCOVE

Step 5

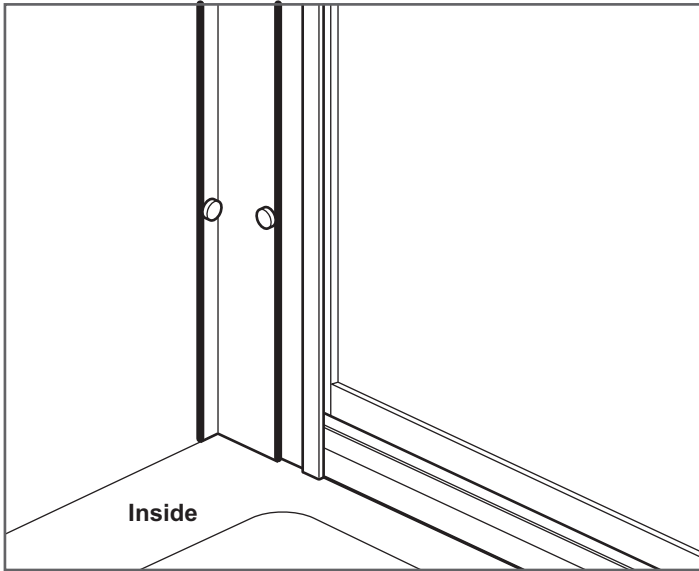

Sealing inside: Run a line of silicone sealant from top to bottom down the joint between the wall channels and tiles, also down the joint where the door slots into the wall channels.

Do not seal the enclosure to the tray on the inside.

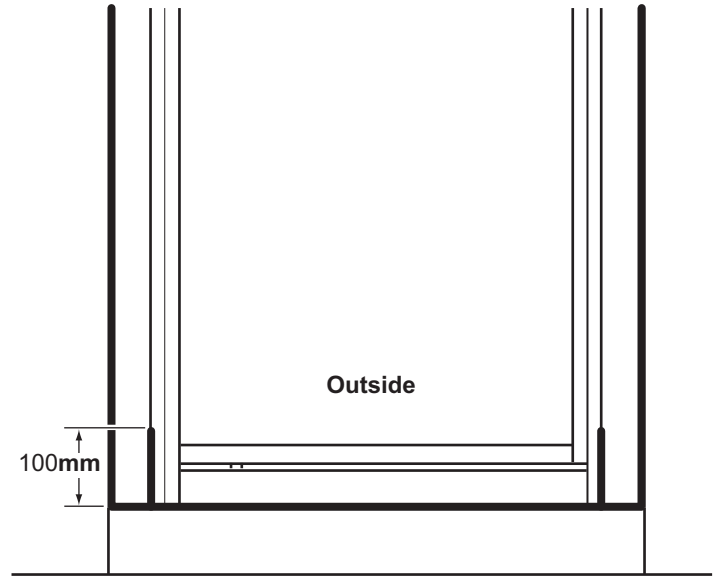

Sealing outside: Run a line of silicone sealant from top to bottom down the joint between the wall channels and tiles. Run a line of silicone sealant 100mm up the joint where the door slots into the wall channels. Run a line of sealant along the base in the joint between the bottom of the enclosure and the tray, from wall to wall.

Step 6 - Optional

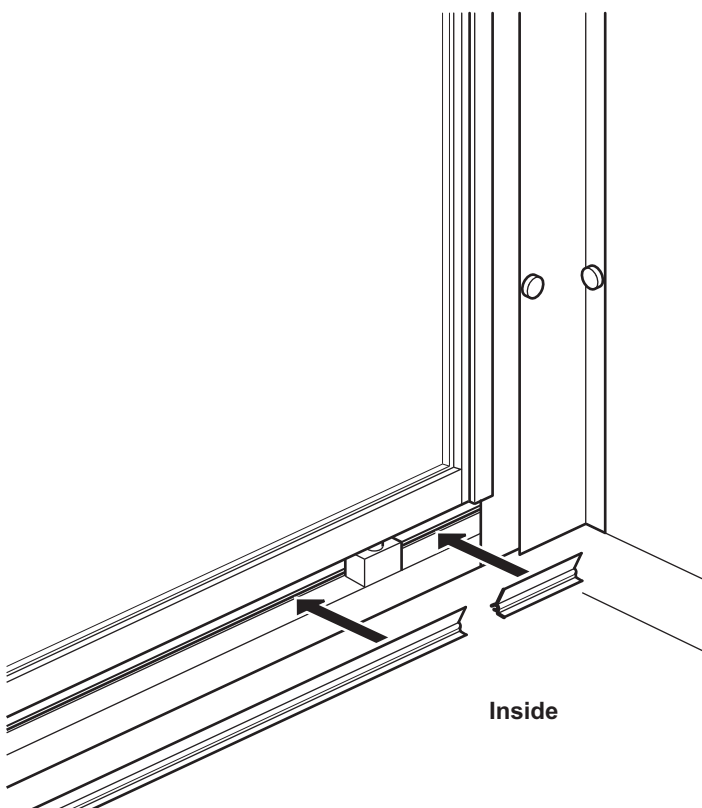

Optional: It is only necessary to fit the plastic Anti splash strip (E) if water splashes out through the gap under the door. Cut the strip to size (using scissors) and push it onto the lug shown on the bottom door frame as shown. **Note:** If the anti splash strip catches on the door, simply trim to fit.

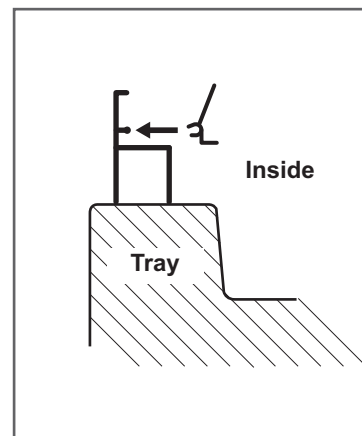

PIVOT DOOR & INLINE PANEL

Step 1

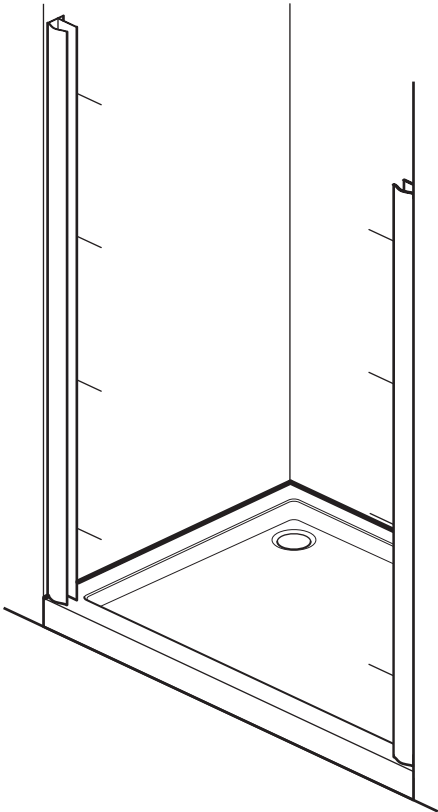

Remove both wall channels from the door frame. Place each wall channel in position on the tray (10 - 15mm in from the outer edge of the tray), ensure they are vertical and mark all 8 fixing holes onto the walls (holes inside).

Drill holes in the positions marked using a 6.5mm masonry drill bit. Insert wall plugs (C) into all of the holes (beyond the thickness of the tile).

On pivot side only: Fix the wall channel to the wall using 4 x40mm screws (B) and push on the screw covers (D).

Note: Inject silicone sealant into the holes before inserting the screws to seal the holes.

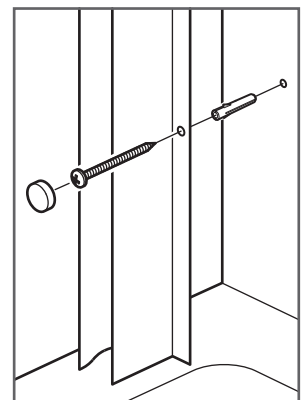
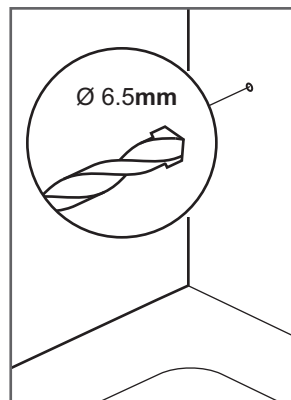
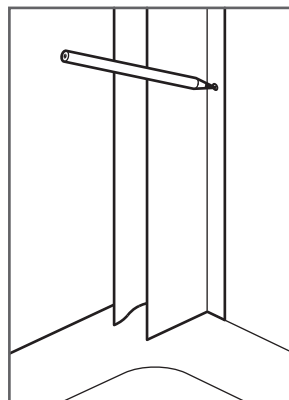

Option

Luxury pivot door only:

Fit the door handle (F) with the grub screws under the outside handle. First dismantle the handle using the hexagonal key supplied. Attach the inner handle tightening the screws (*) onto the door. Re-attach the outer handle as shown.

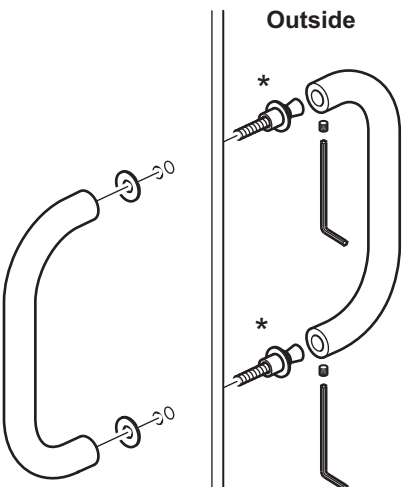

Step 2

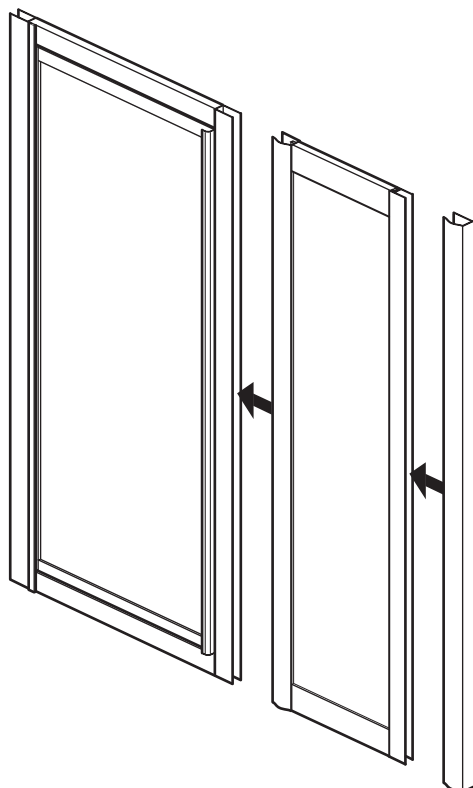

Push the remaining wall channel onto the fat side of the inline panel, then fully push the other side of the inline panel onto the opening/handle side of the door.

Note: The drain slot running across the top and bottom of the inline panel **MUST** be on the inside of the enclosure.

PIVOT DOOR & INLINE PANEL

Step 3

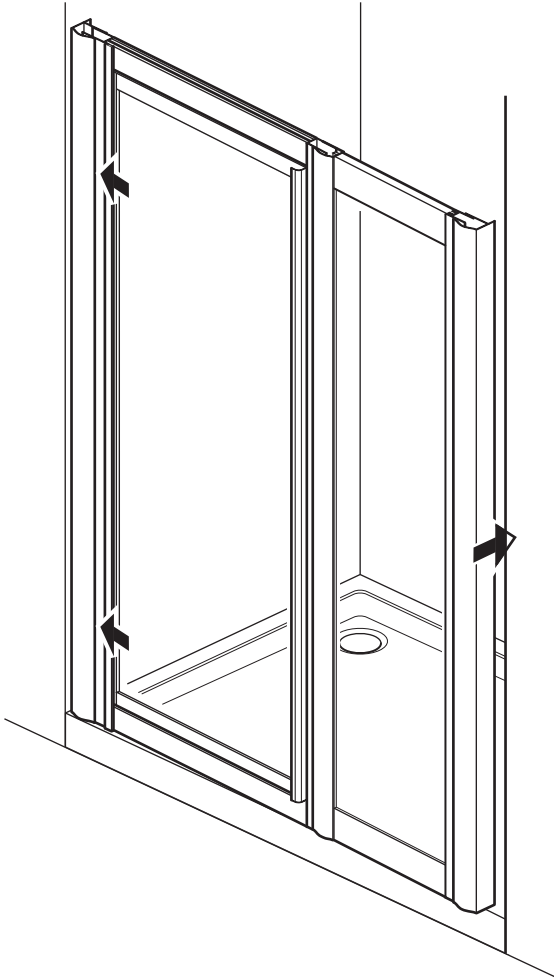

Carefully insert the door/inline panel into the 'fixed' wall channel and swing the free end into position on the opposite wall.

Line up the fixing holes on the second wall channel with those on the wall and fix using 4 x 40mm screws (B) and push on the screw covers (D).

Note: Inject silicone sealant into the holes before inserting the screws to seal the holes.

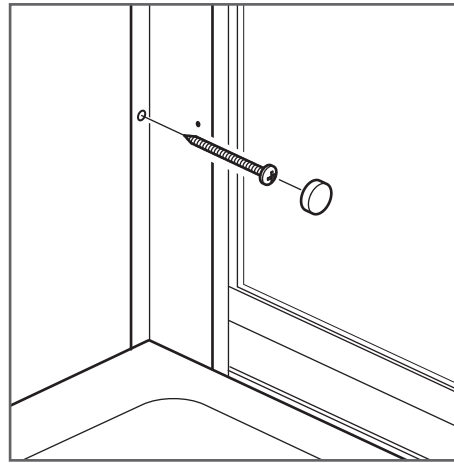

Step 4

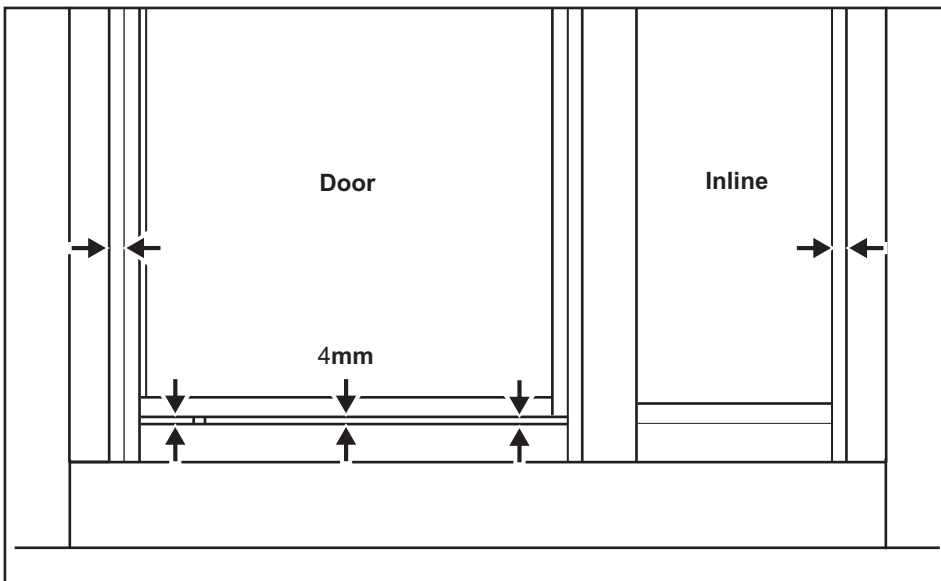

Centre the door/inline panel between the wall channels.

Before fixing the door and inline panel, you must make sure that the door is square within its outer frame.

With the door closed the 4mm gap between the bottom of the door and the frame **MUST** be parallel all the way across. If the gap is not parallel, push the top of the door frame to the left or right so the door hangs squarely within its outer frame.

PIVOT DOOR & INLINE PANEL

Step 5

Once you have checked that the door opens and closes correctly, fix the inline panel and the door to the wall channels, and fix the inline panel to the door.

From inside, drill 3 holes through each wall channel into the inline panel and door (in the marked positions) using a 3.2mm drill bit.

Drill 3 more holes through the inline panel into the door (in the marked positions) using a 3.2mm drill bit.

Note: Stop drilling as soon as you feel the drill break through the first 2 layers of aluminium. Fix using 9 x 10mm screws (A) and push on the screw covers (D).

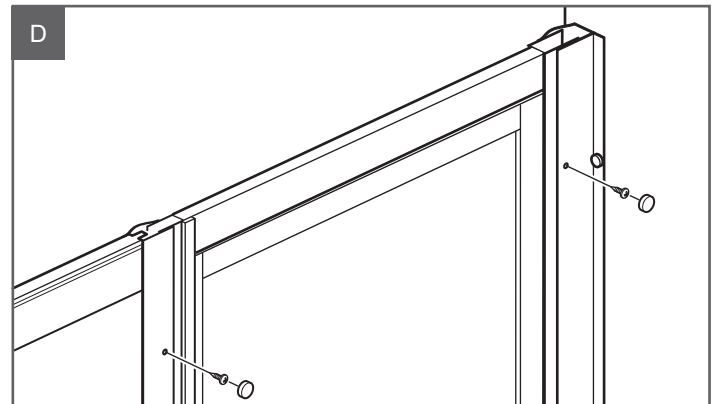
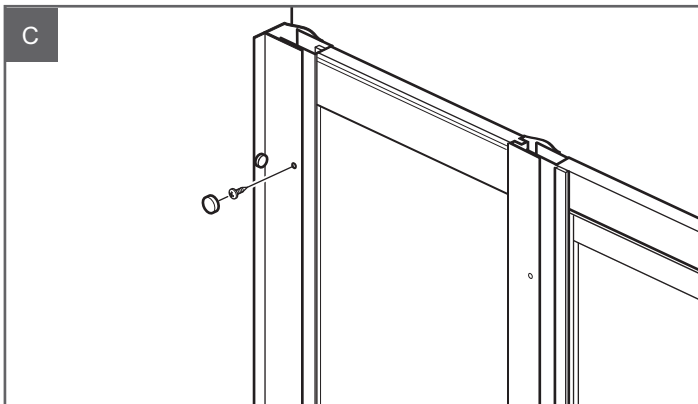
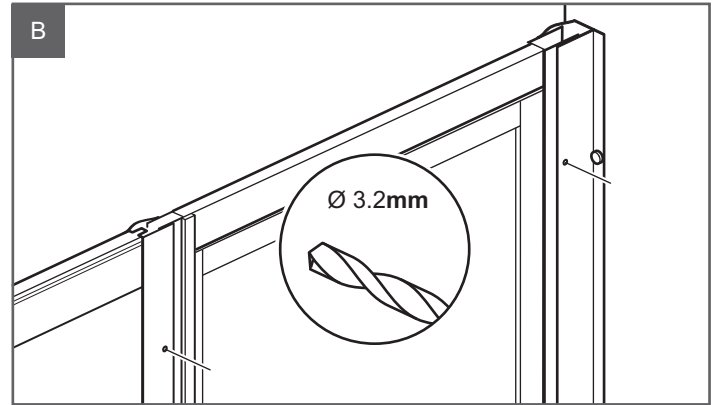
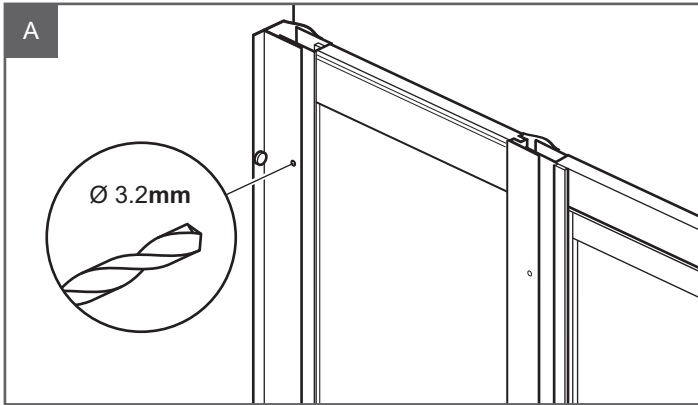

Step 6

Fit the brace bar (G). Position the brace bar in the corner with one end on the inline panel and the other against the wall. Use a spirit level to ensure it is level and mark the screw hole positions onto the inline panel and wall.

Drill a hole in the position marked on the wall using a 6.5mm masonry drill bit. Insert a wall plug (C) into the hole (beyond the thickness of the tile). Drill a 3.2mm hole in the position marked on the inline panel.

Note: Stop drilling as soon as you feel the drill break through the first layer

of aluminium. Fix the brace bar to the wall using a 40mm counter sunk screw (I).

Note: Inject silicone sealant into the hole before inserting the screw to seal the hole.

Fix to the inline panel using a 16mm counter sunk screw (H).

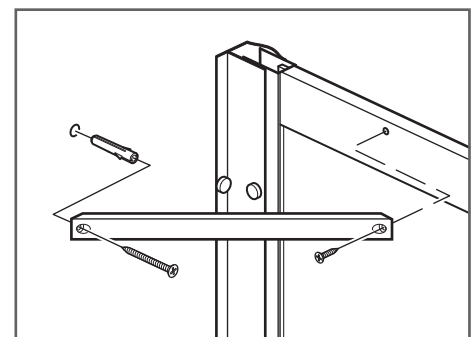
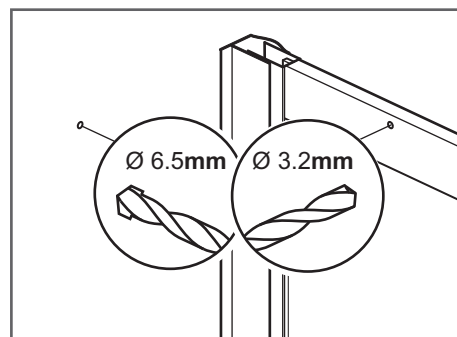
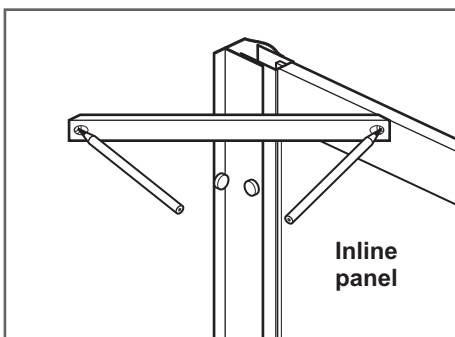

PIVOT DOOR & INLINE PANEL

Step 7

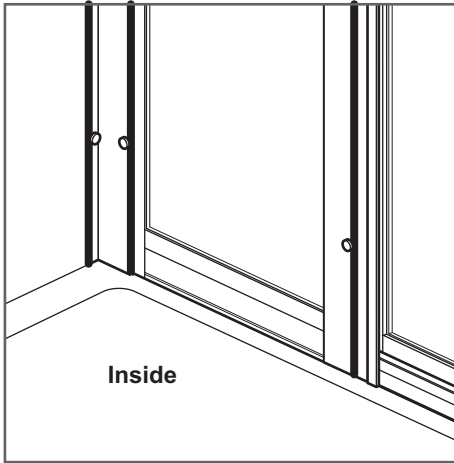

Sealing inside: Run a line of silicone sealant from top to bottom down the joint between the wall channels and tiles. Run a line of silicone sealant from top to bottom down the joint where the door/inline panel slots into the wall channels and where the door slots into the inline panel. **Do not seal the enclosure to the tray on the inside.**

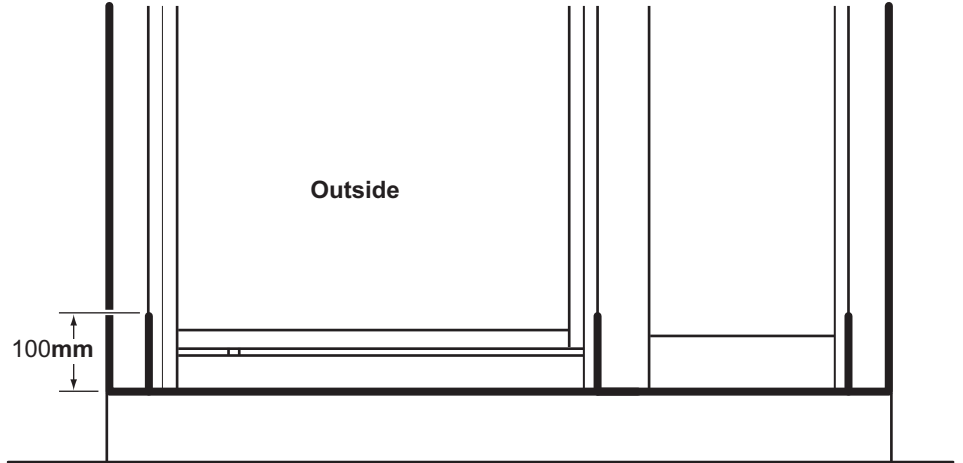

Sealing outside: Run a line of silicone sealant from top to bottom down the joint between the wall channels and tiles. Run a line of silicone sealant 100mm up the joint where the door/inline panel slots into the wall channels and where the door slots into the inline panel. Run a line of sealant along the base in the joint between the bottom of the enclosure and the tray, from wall to wall.

Step 8 - Optional

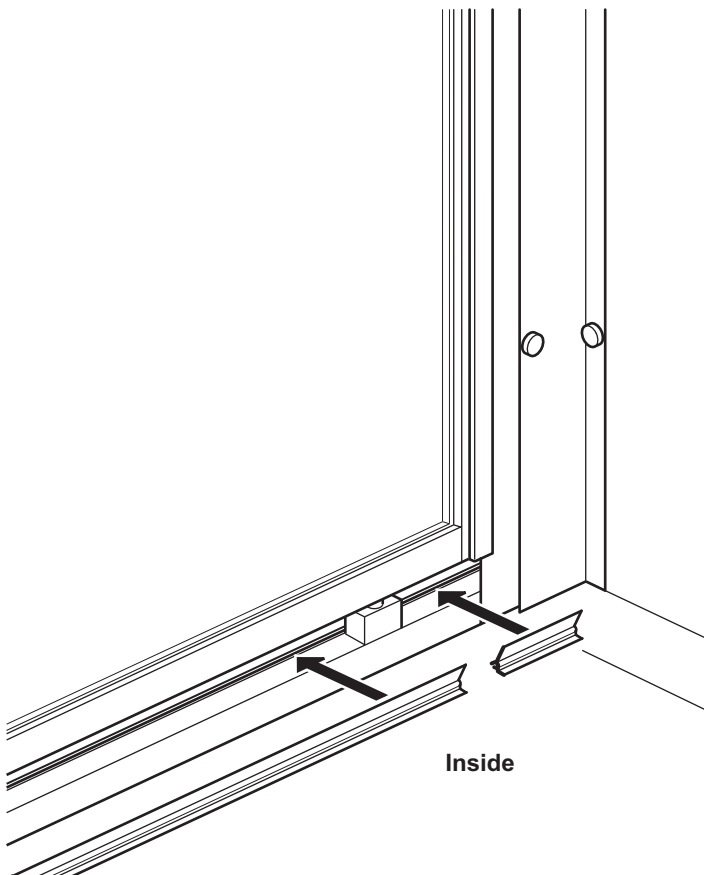

Optional: It is only necessary to fit the plastic Anti splash strip (E) if water splashes out through the gap under the door. Cut the strip to size (using scissors) and push it onto the lug shown on the bottom door frame as shown. **Note:** If the anti splash strip catches on the door, simply trim to fit.

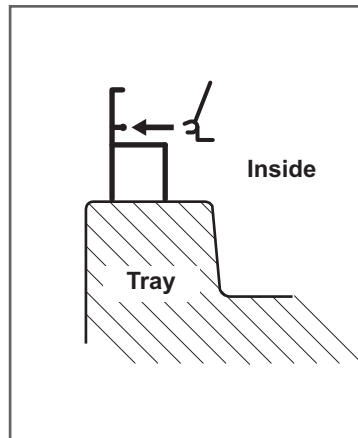

PIVOT DOOR & SIDE PANEL

Step 1

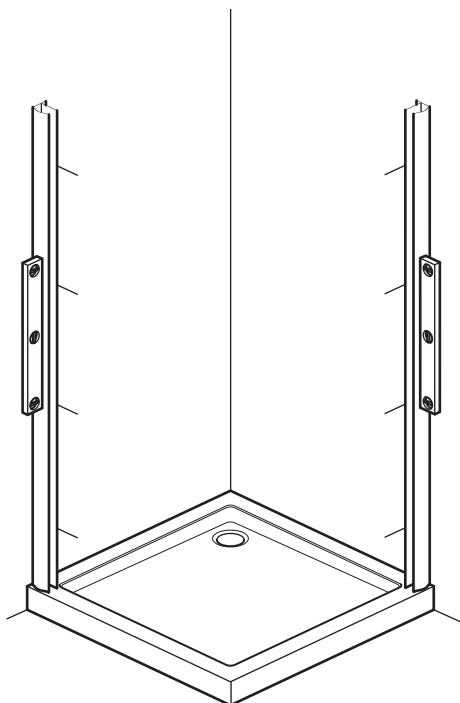

Remove both wall channels from the door frame. Place each wall channel in position on the tray (10 - 15mm in from the outer edges of the tray), use a spirit level to ensure they are vertical and mark all 8 fixing holes onto the walls (holes inside).

Drill holes in the positions marked using a 6.5mm masonry drill bit. Insert wall plugs (C) into all of the holes (beyond the thickness of the tile). Fix the wall channels to the wall using 8 x 40mm screws (B) and push on the screw covers (D).

Note: Inject silicone sealant into the holes before inserting the screws to seal the holes.

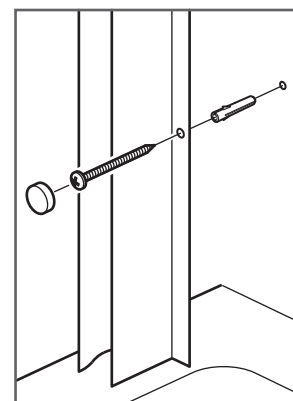
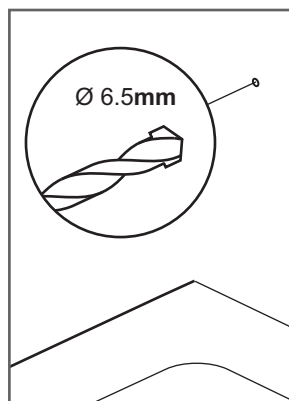
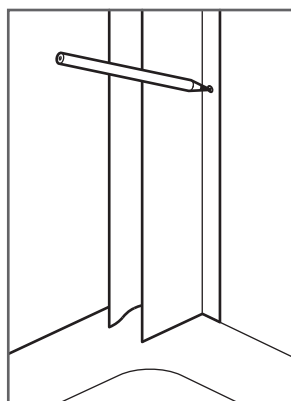

Option

Luxury pivot door only:

Fit the door handle (F) with the grub screws under the outside handle. First dismantle the handle using the hexagonal key supplied. Attach the inner handle tightening the screws (*) onto the door. Re-attach the outer handle as shown.

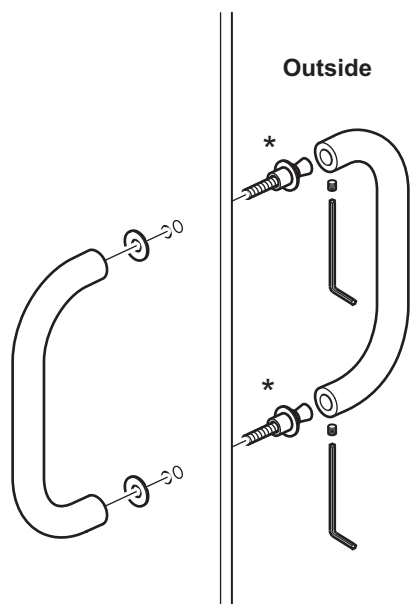

Step 2

Insert the side panel into the wall channel and position correctly on the tray. **Note:** The drain slot running across the top and bottom of the side panel **MUST** be on the inside of the enclosure.

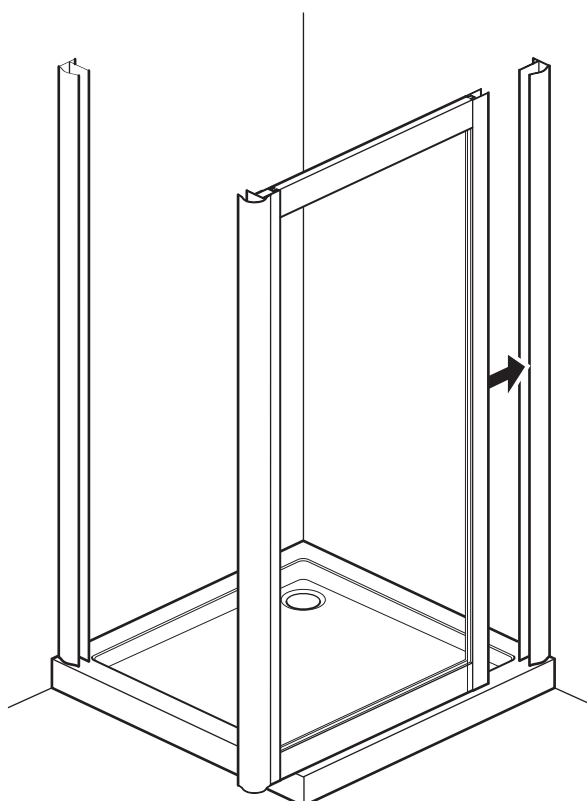

PIVOT DOOR & SIDE PANEL

Step 3

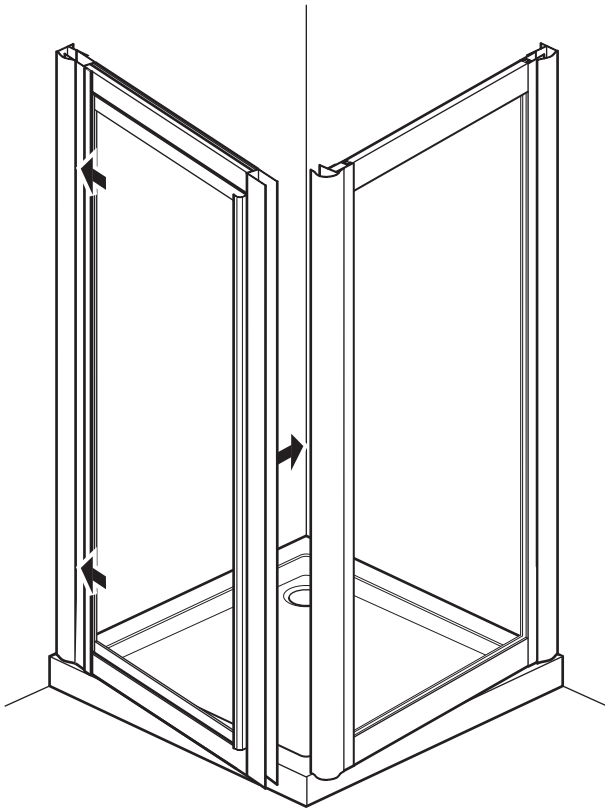

Insert the door into the other wall channel and swing the free end into position on the tray. Push the corner post, fixed to the side panel, onto the side of the door.

Before fixing the door and side panel to the wall channels and corner post you must make sure that the door is square within its outer frame.

First, centre the door between the wall channel and centre post. Next, with the door closed the 4mm gap between the bottom of the door and the frame **MUST** be parallel all the way across. If the gap is not parallel, push the top of the door frame to the left or right so the door hangs squarely within its outer frame.

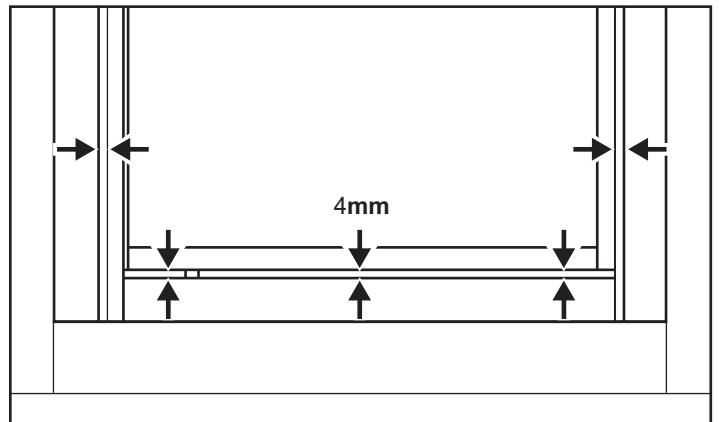

Step 4

Once you have checked that the door opens and closes correctly and the corner post is vertical, fix the door and side panel to the wall channels and corner post.

From inside, drill 3 holes through each wall channel into the door and side panel (in the marked positions) using a 3.2mm drill bit.

Note: Stop drilling as soon as you feel the drill break through the first 2 layers of aluminium. Fix using 6 x 10mm screws (A) and push on the screw covers (D).

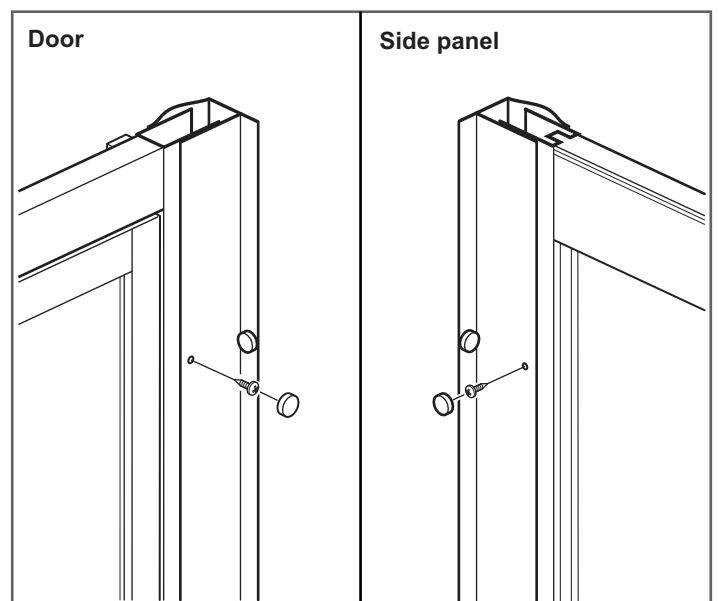
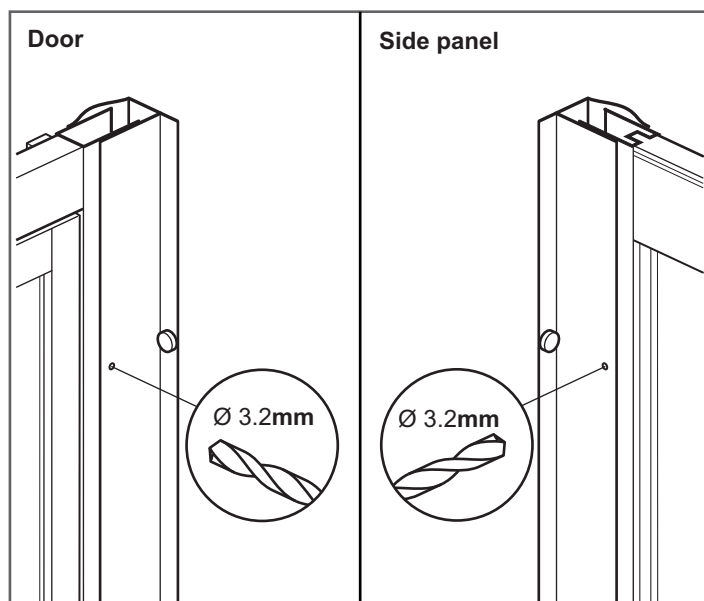

PIVOT DOOR & SIDE PANEL

Step 4 continued

Check again that the corner post is vertical, and drill 6 more holes through the corner post into the door and side panel (in the marked positions) using a 3.2mm drill bit.

Note: Stop drilling as soon as you feel the drill break through the first 2 layers of aluminium. Fix using 6 x 10mm screws (A) and push on the screw covers (D).

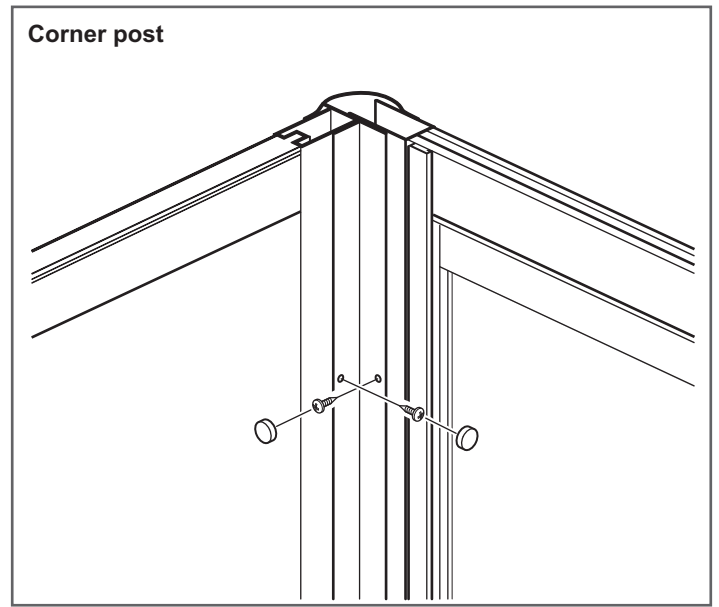
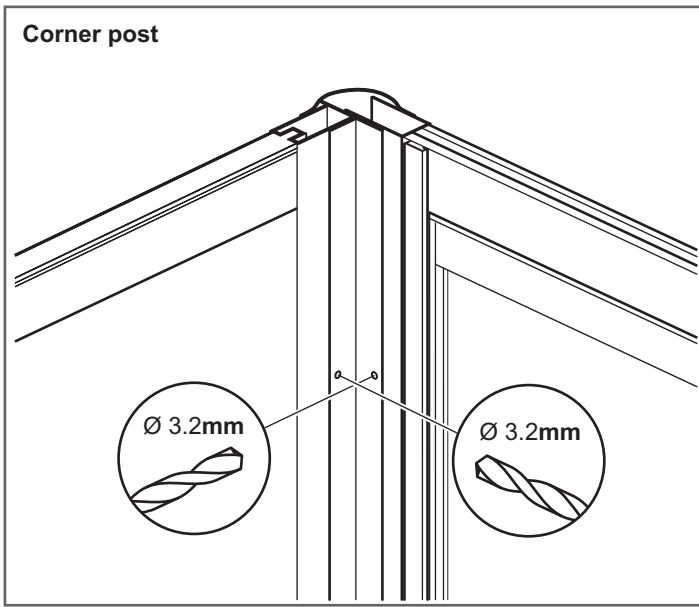

Step 5 - Recommended with the two side panel option only

The brace bars are recommended when there are two side panels in the assembly.

Fit the brace bar (G). Position the brace bar in the corner with one end on the side panel and the other against the wall. Use a spirit level to insure it is level as shown and mark the screw hole positions onto the side panel and wall.

Drill a hole in the position marked on the wall using a 6.5mm masonry drill bit. Insert a wall plug (C) into the hole (beyond the thickness of the tile). Drill a 3.2mm hole in the position marked on the side panel
Note: Stop drilling as soon as you feel the drill break through the first layer of

aluminium. Fix the brace bar to the wall using a 40mm counter sunk screw (I).

Note: Inject silicone sealant into the hole before inserting the screw to seal the hole.

Fix to the side panel using a 16mm counter sunk screw (H).

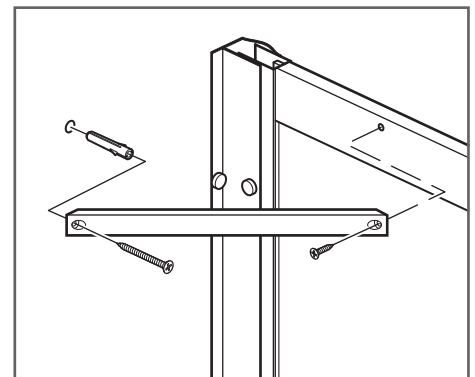
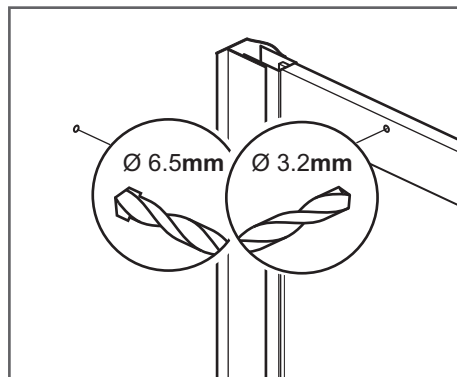
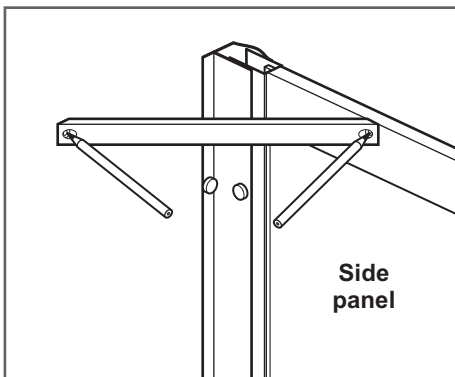

PIVOT DOOR & SIDE PANEL

Step 6

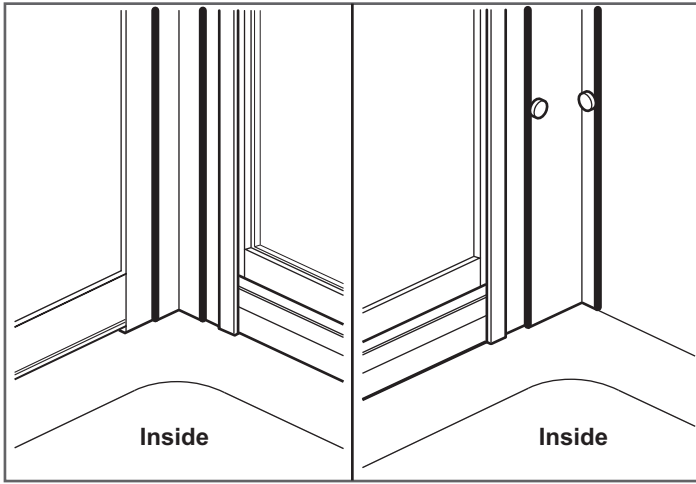

Sealing inside: Run a line of silicone sealant from top to bottom down the joint between the wall channels and tiles. Run a line of silicone sealant from top to bottom down the joint where the door and side panel slot into the wall channels and the door slots into the centre post.

Do not seal the enclosure to the tray on the inside.

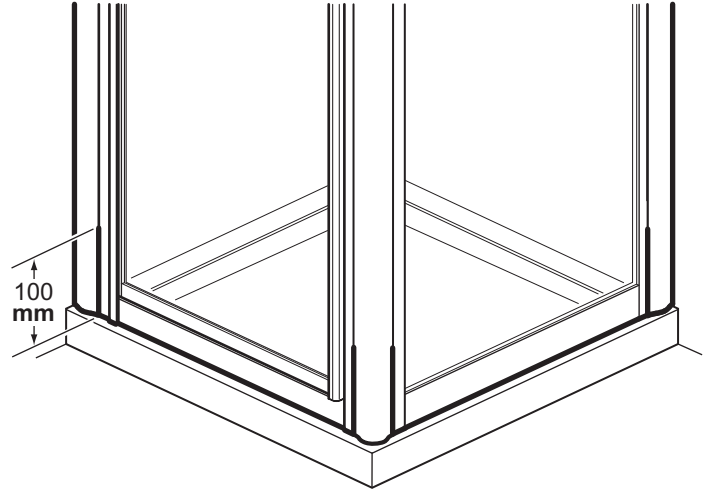

Sealing outside: Run a line of silicone sealant from top to bottom down the joint between the wall channels and tiles. Run a line of silicone sealant 100mm up the joint where the door slots into the wall channels and centre post. Run a line of sealant around the base in the joint between the bottom of the enclosure and the tray, from wall to wall.

Step 7 - Optional

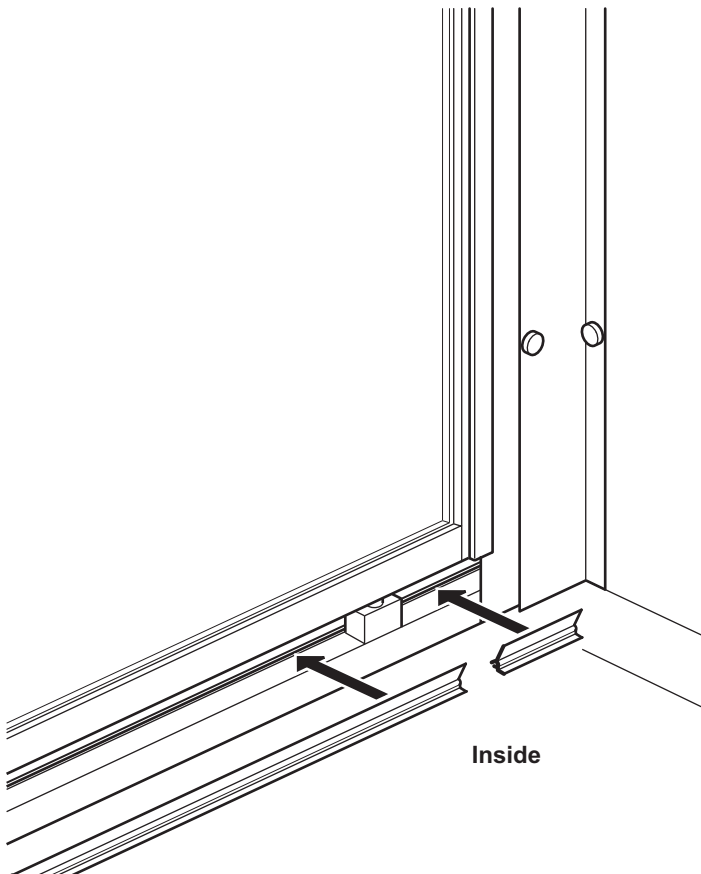

Optional: It is only necessary to fit the plastic Anti splash strip (E) if water splashes out through the gap under the door. Cut the strip to size (using scissors) and push fit onto the lug shown on the bottom door frame as shown.

Note: If the anti splash strip catches on the door, simply trim to fit.

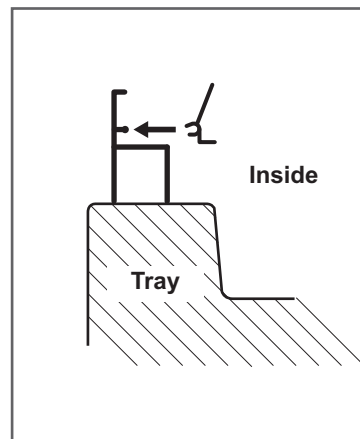

simpsons 

For any further information please contact
Simpsons on: 0845 873 5808

Or visit our web-site at:
www.simpsons-enclosures.co.uk

The manufacturer reserves the right to make technical
modifications without prior notice.