

DE	Gebrauchsanleitung / Montageanleitung	2
FR	Mode d'emploi / Instructions de montage	2
EN	Instructions for use / Assembly instructions	3
IT	Istruzioni per l'uso / Istruzioni per Installazione	3
ES	Modo de empleo / Instrucciones de montaje	4
NL	Gebruiksaanwijzing / Handleiding	4
DK	Brugsanvisning / Monteringsvejledning	5
PT	Instruções para uso / Manual de Instalação	5
PL	Instrukcja obsługi / Instrukcja montażu	6
CS	Návod k použití / Montážní návod	6
SK	Návod na použitie / Montážny návod	7
ZH	用户手册 / 组装说明	7
RU	Руководство пользователя / Инструкция по монтажу	8
FI	Käyttöohje / Asennusohje	8
SV	Bruksanvisning / Monteringsanvisning	9
LT	Vartotojo instrukcija / Montavimo instrukcijos	9
HR	Upute za uporabu / Uputstva za instalaciju	10
RO	Manual de utilizare / Instrucțiuni de montare	10
EL	Οδηγίες χρήσης / Οδηγία συναρμολόγησης	11
SL	Navodilo za uporabo / Navodila za montažo	11
ET	Kasutusjuhend / Paigaldusjuhend	12
LV	Lietošanas pamācība / Montāžas instrukcija	12
SR	Uputstvo za upotrebu / Uputstvo za montažu	13
NO	Bruksanvisning / Montasjeveiledning	13
BG	Инструкция за употреба / Ръководство за монтаж	14
JP	取扱説明書 / 施工説明書	14
SQ	Udhëzuesi i përdorimit / Udhëzime rreth montimit	15
AR	دليل الاستخدام / تعليمات التجميع	15
TR	Kullanım kılavuzu / Montaj kılavuzu	16
HU	Használati útmutató / Szerelési útmutató	17

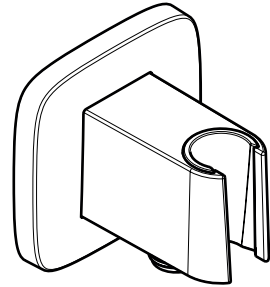

FixFit Q
26887XXX

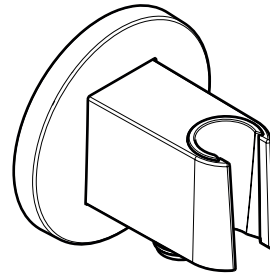

FixFit S
26888XXX

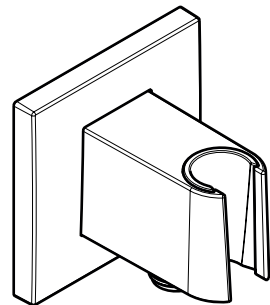

FixFit E
26889XXX



Sicherheitshinweise

Bei der Montage müssen zur Vermeidung von Quetsch- und Schnittverletzungen Handschuhe getragen werden.

Montagehinweise

- Vor der Montage muss das Produkt auf Transportschäden untersucht werden. Nach dem Einbau werden keine Transport- oder Oberflächenschäden anerkannt.
- Die Leitungen und die Armatur müssen nach den gültigen Normen montiert, gespült und geprüft werden.
- Die in den Ländern jeweils gültigen Installationsrichtlinien sind einzuhalten.

Technische Daten

Betriebsdruck:	max. 1 MPa
Empfohlener Betriebsdruck:	0,1 - 0,5 MPa
Prüfdruck:	1,6 MPa (1 MPa = 10 bar = 147 PSI)
Heißwassertemperatur:	max. 60 °C
Freier Durchfluss bei 0,3 MPa::	25,2 l/min
Thermische Desinfektion:	70 °C / 4 min

Das Produkt ist ausschließlich für Trinkwasser konzipiert!

Symbolerklärung



Kein essigsäurehaltiges Silikon verwenden!



Wartung (siehe Seite 21)

Rückflussverhinderer müssen gemäß EN 806-5 regelmäßig in Übereinstimmung mit nationalen oder regionalen Bestimmungen auf ihre Funktion geprüft werden (mindestens einmal jährlich).



Maße (siehe Seite 20)



Serviceteile (siehe Seite 23)

XXX = Farbcodierung
 000 = Chrom
 140 = Brushed Bronze
 340 = Brushed Black Chrome
 670 = Mattschwarz
 700 = Mattweiß



Reinigung (siehe Seite 22)



Montagebeispiele (siehe Seite 21)



Consignes de sécurité

Lors du montage, porter des gants de protection pour éviter toute blessure par écrasement ou coupure.

Instructions pour le montage

- Avant son montage, s'assurer que le produit n'a subi aucun dommage pendant le transport. Après le montage, tout dommage de transport ou de surface ne pourra pas être reconnu.
- Les conduites et la robinetterie doivent être montés, rincés et contrôlés selon les normes en vigueur.
- Les directives d'installation en vigueur dans le pays concerné doivent être respectées.

Informations techniques

Pression de service autorisée:	max. 1 MPa
Pression de service conseillée:	0,1 - 0,5 MPa
Pression maximum de contrôle:	1,6 MPa (1 MPa = 10 bar = 147 PSI)
Température d'eau chaude:	max. 60 °C
Débit libre à 0,3 MPa::	25,2 l/min
Désinfection thermique:	70 °C / 4 min

Le produit est exclusivement conçu pour de l'eau potable!

Description du symbole



Ne pas utiliser de silicone contenant de l'acide acétique!



Entretien (voir pages 21)

Les clapets anti-retour doivent être examinés régulièrement conformément à la norme EN 806-5 ou conformément aux dispositions nationales ou régionales quant à leur fonction (au moins une fois par an).



Dimensions (voir pages 20)



Pièces détachées (voir pages 23)

XXX = Couleurs
 000 = Chromé
 140 = Brushed Bronze
 340 = Brushed Black Chrome
 670 = Matt Black
 700 = Matt White



Nettoyage (voir pages 22)



Exemples de montage (voir pages 21)





Safety Notes

⚠ Gloves should be worn during installation to prevent crushing and cutting injuries.

Installation Instructions

- Prior to installation, inspect the product for transport damages. After it has been installed, no transport or surface damage will be honoured.
- The pipes and the fixture must be installed, flushed and tested as per the applicable standards.
- The plumbing codes applicable in the respective countries must be observed.

Technical Data

Operating pressure: max. 1 MPa

Recommended operating pressure: 0,1 - 0,5 MPa

Test pressure: 1,6 MPa

(1 MPa = 10 bar = 147 PSI)

Hot water temperature: max. 60 °C

Rate of flow by 0,3 MPa:: 25,2 l/min

Thermal disinfection: 70 °C / 4 min

The product is exclusively designed for drinking water!

Symbol description



Do not use silicone containing acetic acid!



Maintenance (see page 21)

The check valves must be checked regularly according to EN 806-5 in accordance with national or regional regulations (at least once a year).



Dimensions (see page 20)



Spare parts (see page 23)

XXX = Colors

000 = Chrome Plated

140 = Brushed Bronze

340 = Brushed Black Chrome

670 = Matt Black

700 = Matt White



Cleaning (see page 22)



Installation example (see page 21)

Indicazioni sulla sicurezza

⚠ Durante il montaggio, per evitare ferite da schiacciamento e da taglio bisogna indossare guanti protettivi.

Istruzioni per il montaggio

- Prima del montaggio è necessario controllare che non ci siano stati danni durante il trasporto. Una volta eseguito il montaggio, non verranno riconosciuti eventuali danni di trasporto o delle superfici.
- Montare, lavare e controllare tubature e rubinetteria rispettando le norme correnti.
- Vanno rispettate le direttive di installazione nazionali vigenti nel rispettivo paese.

Dati tecnici

Pressione d'uso: max. 1 MPa

Pressione d'uso consigliata: 0,1 - 0,5 MPa

Pressione di prova: 1,6 MPa

(1 MPa = 10 bar = 147 PSI)

Temperatura dell'acqua calda: max. 60 °C

Portata a 0,3 MPa:: 25,2 l/min

Disinfezione termica: 70 °C / 4 min

Il prodotto è concepito esclusivamente per acqua potabile!

Descrizione simbolo



Non utilizzare silicone contenente acido acetico!



Manutenzione (vedi pagg. 21)

La valvola di non ritorno deve essere controllata regolarmente come da EN 806-5, secondo le normative nazionali e regionali (almeno una volta all'anno).



Ingombri (vedi pagg. 20)



Parti di ricambio (vedi pagg. 23)

XXX = Trattamento

000 = Cromato

140 = Brushed Bronze

340 = Brushed Black Chrome

670 = Matt Black

700 = Matt White



Pulitura (vedi pagg. 22)



Esempio di installazione

(vedi pagg. 21)

Assembly
(see page 18)



Montaggio
(vedi pagg. 18)





Indicaciones de seguridad

⚠ Durante el montaje deben utilizarse guantes para evitar heridas por aplastamiento o corte.

Indicaciones para el montaje

- Antes del montaje se debe examinar el producto contra daños de transporte. Después de la instalación no se reconoce ningún daño de transporte o de superficie.
- Los conductos y la grifería deben montarse, lavarse y comprobarse según las normas vigentes.
- Es obligatorio el cumplimiento de las directrices de instalación vigentes en el país respectivo.

Datos técnicos

Presión en servicio:	max. 1 MPa
Presión recomendada en servicio:	0,1 - 0,5 MPa
Presión de prueba:	1,6 MPa (1 MPa = 10 bar = 147 PSI)
Temperatura del agua caliente:	max. 60 °C
Caudal con 0,3 MPa:	25,2 l/min
Desinfección térmica:	70 °C / 4 min

El producto ha sido concebido exclusivamente para agua potable.

Descripción de símbolos



No utilizar silicona que contiene ácido acético!



Mantenimiento (ver página 21)

Las válvulas anti-retorno tienen que ser controladas regularmente según la norma EN 806-5, en acuerdo con las regulaciones nacionales o regionales (una vez al año, por lo menos).



Dimensiones (ver página 20)



Repuestos (ver página 23)

- XXX = Acabados
- 000 = Cromado
- 140 = Brushed Bronze
- 340 = Brushed Black Chrome
- 670 = Matt Black
- 700 = Matt White



Limpiar (ver página 22)



Ejemplos de montaje (ver página 21)



Veiligheidsinstructies

⚠ Bij de montage moeten ter voorkoming van kniel- en snijwonden handschoenen worden gedragen.

Montage-instructies

- Vóór de montage moet het product gecontroleerd worden op transportschade. Na de inbouw wordt geen transport- of oppervlakteschade meer aanvaard.
- De leidingen en armaturen moeten gemonteerd, gespoeld en gecontroleerd worden volgens de geldige normen.
- De in de overeenkomstige landen geldende installatierichtlijnen moeten nageleefd worden.

Technische gegevens

Werkdruk: max.	max. 1 MPa
Aanbevolen werkdruk:	0,1 - 0,5 MPa
Getest bij:	1,6 MPa (1 MPa = 10 bar = 147 PSI)
Temperatuur warm water:	max. 60 °C
Vrije doorstroom bij 0,3 MPa::	25,2 l/min
Thermische desinfectie:	70 °C / 4 min

Het product is uitsluitend ontworpen voor drinkwater!

Symboolbeschrijving



Gebruik geen zuurhoudende siliconen!



Onderhoud (zie blz. 21)

Keerleppen moeten volgens EN 806-5 regelmatig en volgens plaatselijk geldende eisen op het functioneren gecontroleerd worden. (Tenminste een keer per jaar)



Maten (zie blz. 20)



Service onderdelen (zie blz. 23)

- XXX = Kleuren
- 000 = Verchroomd
- 140 = Brushed Bronze
- 340 = Brushed Black Chrome
- 670 = Matt Black
- 700 = Matt White



Reinigen (zie blz. 22)



Montagevoorbeelden (zie blz. 21)



Sikkerhedsanvisninger

⚠ Ved monteringen skal der bruges handsker for at undgå kvæstelser og snitsår.

Monteringsanvisninger

- Før monteringen skal produktet kontrolleres for transportskader. Efter monteringen godkendes transportskader eller skader på overfladen ikke længere.
- Ledningerne og armaturerne skal monteres, skylles og kontrolleres iht. de gældende standarder.
- Installationsbestemmelserne, der gælder i det enkelte land, skal overholdes.

Tekniske data

Driftstryk:	max. 1 MPa
Anbefalet driftstryk:	0,1 - 0,5 MPa
Prøvetryk:	1,6 MPa (1 MPa = 10 bar = 147 PSI)
Varmtvandstemperatur:	max. 60 °C
Fri gennemstrømning ved 0,3 MPa::	25,2 l/min
Termisk desinfektion:	70 °C / 4 min

Produktet er udelukkende beregnet til drikkevand!

Symbolbeskrivelse

 Der må ikke benyttes eddikesyreholdig silikone!

Service (se s. 21)

Ifølge EN 806-5 skal gennemstrømningsbegrænsere i overensstemmelse med nationale regler afprøves regelmæssigt (mindst en gang om året).

Målene (se s. 20)

Reservedele (se s. 23)

XXX = Overflade
000 = Krom
140 = Brushed Bronze
340 = Brushed Black Chrome
670 = Matt Black
700 = Matt White

Rengøring (se s. 22)

Monteringsseksempler (se s. 21)

Avisos de segurança

⚠ Durante a montagem devem ser utilizadas luvas de protecção, de modo a evitar ferimentos resultantes de entalamentos e de cortes.

Avisos de montagem

- Antes da montagem deve-se controlar o produto relativamente a danos de transporte. Após a montagem não são aceites quaisquer danos de transporte ou de superfície.
- As tubagens e a torneira têm que ser montadas, enxaguadas e verificadas de acordo com as normas em vigor.
- A prescrições de instalação válidas nos respetivos países devem ser respeitadas.

Dados Técnicos

Pressão de funcionamento:	max. 1 MPa
Pressão de func. recomendada:	0,1 - 0,5 MPa
Pressão testada:	1,6 MPa (1 MPa = 10 bar = 147 PSI)
Temperatura da água quente:	max. 60 °C
Caudal a 0,3 MPa::	25,2 l/min
Desinfecção térmica:	70 °C / 4 min

Este produto foi única e exclusivamente concebido para água potável!

Descrição do símbolo

 Não utilizar silicone que contenha ácido acético!

Manutenção (ver página 21)

As válvulas anti-retorno devem ser verificadas regularmente de acordo com a EN 806-5 segundo os regulamentos nacionais ou regionais (pelo menos uma vez por ano).

Medidas (ver página 20)

Peças de substituição (ver página 23)

XXX = Acabamentos
000 = Cromado
140 = Brushed Bronze
340 = Brushed Black Chrome
670 = Matt Black
700 = Matt White

Limpeza (ver página 22)

Exemplos de montagem (ver página 21)

Montering

(se s. 18) 

Montagem

(ver página 18) 

**Wskazówki bezpieczeństwa**

△ Aby uniknąć zranień na skutek zgniecenia lub przecięcia, podczas montażu należy nosić rękawice ochronne.

Wskazówki montażowe

- Przed montażem należy skontrolować produkt pod kątem szkód transportowych. Po montażu nie widać żadnych szkód transportowych ani szkód na powierzchni.
- Przewody i armatura muszą być montowane, płukane i kontrolowane według obowiązujących norm.
- Należy przestrzegać wytycznych instalacyjnych obowiązujących w danym kraju.

Dane techniczne

Ciśnienie robocze:	maks. 1 MPa
Zalecane ciśnienie robocze:	0,1 - 0,5 MPa
Ciśnienie próbne:	1,6 MPa (1 MPa = 10 bary = 147 PSI)
Temperatura wody gorącej:	maks. 60 °C
Swobodny przepływ przy 0,3 MPa::	25,2 l/min
Dezynfekcja termiczna:	70 °C / 4 min

Produkt przeznaczony wyłącznie do wody pitnej!

Opis symbolu

Nie stosować silikonów zawierających kwas octowy!

**Konserwacja (patrz strona 21)**

Zgodnie z normą EN 806-5, krajowymi i miejscowymi przepisami, działanie zabezpieczeń przed przepływem zwrótnym musi być kontrolowane (przynajmniej raz w roku).

**Wymiary (patrz strona 20)****Części serwisowe (patrz strona 23)**

XXX = Kody kolorów
000 = Chrom
140 = Brushed Bronze
340 = Brushed Black Chrome
670 = Matt Black
700 = Matt White

**Czyszczenie (patrz strona 22)****Przykłady montażowe (patrz strona 21)****Bezpečnostní pokyny**

△ Pro zabránění řezným zraněním a pohmožděním je nutné při montáži nosit rukavice.

Pokyny k montáži

- Před montáží je třeba produkt zkontrolovat, zda nebyl při transportu poškozen. Po zabudování nebudou uznaný žádné škody způsobené transportem nebo poškození povrchu.
- Vedení a armatura musí být namontovány, propláchnuty a otestovány podle platných norem.
- Je třeba dodržovat montážní pravidla platná v dané zemi.

Technické údaje

Provozní tlak:	max. 1 MPa
Doporučený provozní tlak:	0,1 - 0,5 MPa
Zkušební tlak:	1,6 MPa (1 MPa = 10 bar = 147 PSI)
Teplota horké vody:	max. 60 °C
Volný průtok při 0,3 MPa:	25,2 l/min
Teplná desinfekce:	70 °C / 4 min

Výrobky Hansgrohe jsou vhodné pro přímý kontakt s pitnou vodou.

Popis symbolů

Nepoužívat silikon s obsahem kyseliny octové!

**Údržba (viz strana 21)**

U zpětných ventilů se musí podle EN 806-5 v souladu s národními nebo regionálními předpisy testovat jejich funkčnost (alespoň jednou ročně).

**Rozměry (viz strana 20)****Servisní díly (viz strana 23)**

XXX = Kód povrchové úpravy
000 = Chrom
140 = Brushed Bronze
340 = Brushed Black Chrome
670 = Matt Black
700 = Matt White

**Čištění (viz strana 22)****Příklady montáže (viz strana 21)**

**! Bezpečnostné pokyny**

△ Pri montáži musíte nosiť rukavice, aby ste predišli pomliaždeninám a rezným poraneniam.

Pokyny pre montáž

- Pred montážou musíte produkt skontrolovať, či nebol počas transportu poškodený. Po zabudovaní nebudú uznané žiadne škody spôsobené transportom alebo poškodenia povrchu.
- Potrubia a vybavenie musia byť namontované, prepláchnuté a vybavené v platnom normami.
- Je potrebné dodržiavať smernice o inštalácii, ktoré sú práve teraz platné v krajinách.

Technické údaje

Prevádzkový tlak:	max. 1 MPa
Doporučený prevádzkový tlak:	0,1 - 0,5 MPa
Skúšobný tlak:	1,6 MPa (1 MPa = 10 bar = 147 PSI)
Teplota teplej vody:	max. 60°C
Volný prietok pri 0,3 MPa:	25,2 l/min
Termická dezinfekcia:	70°C / 4 min

Výrobok je koncipovaný výhradne pre pitnú vodu!

Popis symbolov

 Nepoužívať silikón s obsahom kyseliny octovej!

Údržba (viď strana 21)

Pri spätných ventiloch sa musí podľa EN 806-5 v súlade s národnými alebo regionálnymi predpismi testovať ich funkčnosť (aspoň raz ročne).

Rozmery (viď strana 20)**Servisné diely** (viď strana 23)

XXX = Farebné označenie
000 = Chróm
140 = Brushed Bronze
340 = Brushed Black Chrome
670 = Matt Black
700 = Matt White

Čistenie (viď strana 22)**i Príklady montáže** (viď strana 21)**! 安全技巧**

△ 装配时为避免挤压和切割受伤，必须戴上手套。

安装提示

- 安装前必须检查产品是否受到运输损害。安装后将不认可运输损害或表面损伤。
- 管道和阀门必须根据通用标准进行安装、冲洗和检查。
- 请遵守当地国家现行的安装规定。

技术参数

工作压力:	最大 1 MPa
推荐工作压力:	0,1 - 0,5 MPa
测试压力:	1,6 MPa (1 MPa = 10 bar = 147 PSI)
热水温度:	最大 60°C
0,3 MPa时的流速: :	25,2 升/分钟
热力消毒:	70°C / 4 分钟

该产品专为饮用水设计！

符号说明

 请勿使用含有乙酸的硅胶！

 保养 (参见第页 21)

单向阀必须在符合国家或当地的法律的情况下按照EN 806-5定期检查 (至少一年一次)。

 大小 (参见第页 20)

 备用零件 (参见第页 23)

XXX = 颜色代码
000 = 镀铬
140 = Brushed Bronze
340 = Brushed Black Chrome
670 = Matt Black
700 = Matt White

 清洗 (参见第页 22)

i 安装示意 (参见第页 21)



Указания по технике безопасности

Во время монтажа следует надеть перчатки во избежание прищемления и порезов.

Указания по монтажу

- Перед монтажом следует проверить изделие на предмет повреждений при перевозке. После монтажа претензии о возмещении ущерба за повреждения при перевозке или повреждения поверхностей не принимаются.
- Трубы и арматура должны быть установлены, промыты и проверены в соответствии с действующими нормами.
- Необходимо соблюдать требования по монтажу, действующие в соответствующих странах.

Технические данные

Рабочее давление: не более. 1 МПа
 Рекомендуемое рабочее давление: 0,1 - 0,5 МПа
 Давление: 1,6 МПа
 (1 МПа = 10 bar = 147 PSI)
 Температура горячей воды: не более. 60 °C
 Свободное истечение при 0,3 МПа: 25,2 л/мин
 Термическая дезинфекция: 70 °C / 4 мин
 Изделие предназначено исключительно для питьевой воды!

Описание символов



Не применяйте силикон, содержащий уксусную кислоту.



Техническое обслуживание (см. стр. 21)

Защита обратного тока должна регулярно проверяться (минимум один раз в год) по стандарту EN 806-5 или в соответствии с национальными или региональными нормативами



Размеры (см. стр. 20)



Комплект (см. стр. 23)

XXX = Цветная кодировка
 000 = Хром
 140 = Brushed Bronze
 340 = Brushed Black Chrome
 670 = Matt Black
 700 = Matt White



Очистка (см. стр. 22)



варианты установки (см. стр. 21)



Turvallisuusohjeet

Asennuksessa on käytettävä käsineitä puristumien ja viiltojen aiheuttamien tapaturmien estämiseksi.

Asennusohjeet

- Ennen asennusta on tarkastettava tuotteen mahdolliset kuljetusvahingot. Asennuksen jälkeen kuljetus- ja pintavaurioita ei hyväksytä.
- Putket ja hana on asennettava, huuhdeltava ja tarkastettava voimassa olevien standardien mukaisesti.
- Jokaisessa maassa on noudatettava siellä päteviä asennusohjeita.

Tekniset tiedot

Käyttöpaine: maks. 1 МПа
 Suositeltu käyttöpaine: 0,1 - 0,5 МПа
 Koestuspaine: 1,6 МПа
 (1 МПа = 10 bar = 147 PSI)
 Kuuman veden lämpötila: maks. 60 °C
 Vapaa läpivirtaus 0,3 МПа paineella: 25,2 л/мин
 Lämpödesinfektio: 70 °C / 4 min
 Tuote on suunniteltu käytettäväksi ainoastaan juomaveden kanssa!

Merkin kuvaus



Älä käytä etikahappopitoista silikonia!



Huolto (katso sivu 21)

Vastaventtiilien toiminta on tarkastettava säännöllisesti paikallisten ja kansallisten määräysten mukaisesti (EN 806-5, vähintään kerran vuodessa).



Mitat (katso sivu 20)



Varaosat (katso sivu 23)

XXX = Värikoodaus
 000 = Kromi
 140 = Brushed Bronze
 340 = Brushed Black Chrome
 670 = Matt Black
 700 = Matt White



Puhdistus (katso sivu 22)



Asennusesimerkkejä (katso sivu 21)



Säkerhetsanvisningar

⚠ Handskar ska bäras under monteringsarbetet så att man kan undvika kläm- och skärskador.

Monteringsanvisningar

- Det måste undersökas om produkten har transportskador innan den monteras. Efter monteringen accepteras inga transport- eller ytskiktskador.
- Ledningarna och blandaren måste monteras, spolas igenom och kontrolleras enligt de gällande normerna.
- De installationsriktlinjer som gäller i länderna ska följas.

Tekniska data

Driftstryck:	max. 1 MPa
Rek. driftstryck:	0,1 - 0,5 MPa
Tryck vid provtryckning:	1,6 MPa (1 MPa = 10 bar = 147 PSI)

Varmvattentemperatur: max. 60°C

Fri genomströmning vid 0,3 MPa:: 25,2 l/min

Termisk desinfektion: 70°C / 4 min

Produkten är enbart avsedd för dricksvatten!

Symbolförklaring



Använd inte silikon som innehåller ättiksyra!



Skötsel (se sidan 21)

Backventilens funktion måste kontrolleras regelbundet enligt nationella eller regionala bestämmelser i enlighet med EN 806-5 (minst en gång per år).



Måtten (se sidan 20)



Reservdelar (se sidan 23)

XXX = Färgkodning

000 = Krom

140 = Brushed Bronze

340 = Brushed Black Chrome

670 = Matt Black

700 = Matt White



Rengöring (se sidan 22)



Monteringsexempel (se sidan 21)



Saugumo technikos nurodymai

⚠ Apsaugai nuo užspaudimo ir įsijiovimo montavimo metu mūvėkite pirštines.

Montavimo instrukcija

- Prieš montuojant būtina patikrinti, ar gaminys nebuvo pažeistas transportavimo metu. Sumontavus pretenzijos dėl transportavimo ir paviršiaus pažeidimų nepriimamos.
- Vamzdžiai ir sujungimai turi būti montuojami, plaunami ir tikrinami pagal galiojančias normas.
- Laikykites atitinkamoje šalyje galiojančių direktyvų dėl įrengimo.

Techniniai duomenys

Darbinis slėgis:	ne daugiau kaip 1 MPa
Rekomenduojamas slėgis:	0,1 - 0,5 MPa
Bandomasis slėgis:	1,6 MPa (1 MPa = 10 bar = 147 PSI)

Karšto vandens temperatūra: ne daugiau kaip 60°C

Laisvas vandens pralaidumas esant 0,3 MPa slėgiui::

25,2 l/min

Terminis dezinfekavimas: 70°C / 4 min

Produkta skirtas tik geriamajam vandeniui!

Simbolio aprašymas



Nenaudokite silikono, kurio sudėtyje yra acto rūgšties!



Techninis aptarnavimas (žr. psl. 21)

Atbulinio vožtuvo apsauga privalo būti tikrinama reguliariai (mažiausiai kartą per metus) pagal EN 806-5 arba pagal galiojančias nacionalines arba regionines normas.



Įšmatavimai (žr. psl. 20)



Atsarginės dalys (žr. psl. 23)

XXX = Spalvos

000 = Chrom

140 = Brushed Bronze

340 = Brushed Black Chrome

670 = Matt Black

700 = Matt White



Valymas (žr. psl. 22)



Montavimo pavyzdžiai (žr. psl. 21)





Sigurnosne upute

⚠ Prilikom montaže se radi sprječavanja prignječenja i posjekotina moraju nositi rukavice.

Upute za montažu

- Prije montaže mora se provjeriti je li proizvod oštećen prilikom transporta. Nakon ugradnje se ne priznaju nikakve reklamacije koje se odnose na površinska i transportna oštećenja.
- Cijevi i armatura moraju biti postavljeni, isprani i testirani prema važećim normama.
- Obvezno se moraju uvažiti propisi o instalacijama koji vrijede u dotičnoj zemlji.

Tehnički podatci

Najveći dopušteni tlak:	tlak 1 MPa
Preporučeni tlak:	0,1 - 0,5 MPa
Probni tlak:	1,6 MPa
	(1 MPa = 10 bar = 147 PSI)
Temperatura vruće vode:	tlak 60°C
Slobodan protok na 0,3 MPa::	25,2 l/min
Termička dezinfekcija:	70°C / 4 min

Proizvod je koncipiran isključivo za pitku vodu!

Opis simbola



Nemojte koristiti silikon koji sadrži octenu kiselinu!



Održavanje (pogledaj stranicu 21)

Ispravnost nepovratnog ventila mora se redovito provjeravati prema standardu EN 806-5 i u skladu sa važećim propisima (najmanje jednom godišnje).



Mjere (pogledaj stranicu 20)



Rezervni djelovi (pogledaj stranicu 23)

XXX = Boje
 000 = Krom
 140 = Brushed Bronze
 340 = Brushed Black Chrome
 670 = Matt Black
 700 = Matt White



Čišćenje (pogledaj stranicu 22)



Primjeri instalacija (pogledaj stranicu 21)



Instrucțiuni de siguranță

⚠ La montare utilizați mănuși pentru evitarea contuziunilor și tăierii mâinilor.

Instrucțiuni de montare

- Înainte de instalare verificați, dacă produsul prezintă deteriorări de transport. După instalare garanția nu acoperă deteriorările de transport și cele de suprafață.
- Conductele și bateriile trebuie montate, spălate și verificate conform normelor în vigoare.
- Respectați reglementările referitoare la instalare valabile în țara respectivă.

Date tehnice

Presiune de funcționare:	max. 1 MPa
Presiune de funcționare recomandată:	0,1 - 0,5 MPa
Presiune de verificare:	1,6 MPa
	(1 MPa = 10 bar = 147 PSI)
Temperatura apei calde:	max. 60°C
Debit cu curgere liberă la 0,3 MPa::	25,2 l/min
Dezinfecție termică:	70°C / 4 min

Produsul este destinat exclusiv pentru apă potabilă.

Descrierea simbolurilor



Nu utilizați silicon cu conținut de acid acetic!



Întreținere (vezi pag. 21)

Supapele antiretur trebuie verificate regulat conform EN 806-5 și standardele naționale sau regionale (cel puțin o dată pe an).



Dimensiuni (vezi pag. 20)



Piese de schimb (vezi pag. 23)

XXX = Coduri de culori
 000 = Crom
 140 = Brushed Bronze
 340 = Brushed Black Chrome
 670 = Matt Black
 700 = Matt White



Curățare (vezi pag. 22)



Exemple de montare (vezi pag. 21)

Sastavljanje

(pogledaj stranicu 18) 

Montare

(vezi pag. 18) 



Υποδειξεις ασφαλείας

⚠ Για να αποφύγετε τραυματισμούς κατά τη συναρμο-
λόγηση πρέπει να φοράτε γάντια.

Οδηγίες συναρμολόγησης

- Πριν τη συναρμολόγηση πρέπει να εξεταστεί το προϊόν για ζημιές μεταφοράς. Μετά την εγκατάσταση δεν αναγνωρίζονται ζημιές από τη μεταφορά ή επιφανειακές ζημιές.
- Οι σπλήνες και η μπαταρία πρέπει να τοποθετηθούν σύμφωνα με τα ισχύοντα πρότυπα, να τεθούν υπό πίεση και να δοκιμαστούν.
- Θα πρέπει να τηρούνται οι οδηγίες εγκατάστασης που ισχύουν σε κάθε κράτος.

Τεχνικά Χαρακτηριστικά

Λειτουργία πίεσης:	έως 1 MPa
Συνιστώμενη λειτουργία πίεσης:	0,1 - 0,5 MPa
Πίεση ελέγχου:	1,6 MPa
	(1 MPa = 10 bar = 147 PSI)
Θερμοκρασία ζεστού νερού:	έως 60 °C
Ελεύθερη ροή στα 0,3 MPa::	25,2 l/min
Θερμική απολύμανση:	70 °C / 4 min

Το προϊόν έχει σχεδιαστεί αποκλειστικά για πόσιμο νερό!

Περιγραφή συμβόλων



Μην χρησιμοποιείτε σιλικόνη που περιέχει οξικό οξύ!



Συντήρηση (βλ. Σελίδα 21)

Οι βαλβίδες αντεπιστροφής πρέπει να ελέγχονται τακτικά ως προς τη λειτουργία τους, σύμφωνα με το πρότυπο EN 806-5, σε σχέση με τους ισχύοντες εθνικούς ή τοπικούς κανόνες (το ελάχιστο μια φορά το χρόνο).



Διαστάσεις (βλ. Σελίδα 20)



Ανταλλακτικά (βλ. Σελίδα 23)

XXX = Χρώματα
000 = ΕπιχρΩμιΩμένο
140 = Brushed Bronze
340 = Brushed Black Chrome
670 = Matt Black
700 = Matt White



Καθαρισμός (βλ. Σελίδα 22)



Παραδείγματα συναρμολόγησης
(βλ. Σελίδα 21)

Συναρμολόγηση

(βλ. Σελίδα 18)

Varnostna opozorila

⚠ Pri montaži je treba nositi rokavice, da se preprečijo poškodbe zaradi zmečkanja ali urezov.

Navodila za montažo

- Pred montažo je treba izdelek preveriti glede morebitnih transportnih poškodb. Po vgradnji transportne ali površinske poškodbe ne bodo več priznane.
- Cevi in armaturo je treba montirati, izprati in preveriti po veljavnih standardih.
- Upoštevati je treba pravilnike o inštalacijah, ki veljajo v posamezni državi.

Tehnični podatki

Delovni tlak:	maks. 1 MPa
Priporočeni delovni tlak:	0,1 - 0,5 MPa
Preskusni tlak:	1,6 MPa
	(1 MPa = 10 bar = 147 PSI)
Temperatura tople vode:	maks. 60 °C
Prost pretok pri 0,3 MPa::	25,2 l/min
Termična dezinfekcija:	70 °C / 4 min
Proizvod je zasnovan izključno za sanitarno vodo!	

Opis simbola



Ne smete uporabiti silikona, ki vsebuje ocetno kislino!



Vzdrževanje (glejte stran 21)

Delovanje protipovratnega ventila je potrebno v skladu z EN 806-5 in skladno z državnimi in regionalnimi določili redno testirati (najmanj enkrat letno).



Mere (glejte stran 20)



Rezervni deli (glejte stran 23)

XXX = Barve
000 = Krom
140 = Brushed Bronze
340 = Brushed Black Chrome
670 = Matt Black
700 = Matt White



Čiščenje (glejte stran 22)



Primeri montaže (glejte stran 21)

Montaža

(glejte stran 18)



Ohutusjuhised

△ Kandke paigaldamisel muljumis- ja löikevigastuste vältimiseks kindaid.

Paigaldamisjuhised

- Enne paigaldamist tuleb toodet kontrollida transportikahjustuste osas. Pärast paigaldamist ei tunnustata enam transporti- või pinnakahjustuste kaebuseid.
- Voolikute ja segisti paigaldamisel, loputamisel ja kontrollimisel tuleb lähtuda kehtivatest normatiividest.
- Vastavas riigis kehtivaid paigalduseeskirju tuleb järgida.

Tehnilised andmed

Töörõhk maks. 1 MPa
 Soovitav töörõhk: 0,1 - 0,5 MPa
 Kontrollsurve: 1,6 MPa
 (1 MPa = 10 baari = 147 PSI)

Kuuma vee temperatuur: maks. 60 °C
 Äravoolu surve 0,3 MPa: 25,2 l/min
 Termiline desinfitatsioon: 70 °C / 4 min
 Toode on ette nähtud eranditult joogivee jaoks!

Sümbolite kirjeldus



Ärge kasutage äädikhapet sisaldavat silikooni!



Hooldus (vt lk 21)

Tagasilöögiklappide toimimist tuleb kooskõlas riiklike ja regionaalsete määrustega regulaarselt kontrollida vastavalt standardile EN 806-5 (vähemalt kord aastas).



Mõõtude (vt lk 20)



Varuosad (vt lk 23)

XXX = Värvid
 000 = Kroom
 140 = Brushed Bronze
 340 = Brushed Black Chrome
 670 = Matt Black
 700 = Matt White



Puhastamine (vt lk 22)



Paigalduse näited (vt lk 21)



Drošības norādes

△ Montāžas laikā, lai izvairītos no saspiedumiem un iegriezumiem, nepieciešams nēsāt cimdus.

Norādījumi montāžai

- Pirms montāžas nepieciešams pārbaudīt, vai produktam transportēšanas laikā nav radušies bojājumi. Pēc iebūvēšanas bojājumi, kas radušies transportēšanas laikā, vai virsmas bojājumi netiek atzīti.
- Cauruļvadi un armatūra ir jāuzstāda, jāizskalo un jāpārbauda saskaņā ar spēkā esošajiem standartiem.
- Jāievēro attiecīgās valstīs spēkā esošās montāžas prasības.

Tehniskie dati

Darba spiediens: maks. 1 MPa
 Ieteicamais darba spiediens: 0,1 - 0,5 MPa
 Pārbaudes spiediens: 1,6 MPa
 (1 MPa = 10 bar = 147 PSI)

Karstā ūdens temperatūra: maks. 60 °C
 Brīva caurplūde, ja ir 0,3 MPa: 25,2 l/min
 Termiskā dezinfekcija: 70 °C / 4 min

Izstrādājums ir paredzēts tikai dzeramajam ūdenim!

Simbolu nozīme



Neizmantojot silikonu, kas satur etiķskābi!



Apkope (skat. lpp. 21)

Regulāri jāpārbauda pretvārsta funkcija saskaņā ar EN 806-5 saistībā ar nacionālajiem vai vietējiem noteikumiem (vismaz vienreiz gadā).



Izmērus (skat. lpp. 20)



Rezerves daļas (skat. lpp. 23)

XXX = Krāsu kodi
 000 = Hroma
 140 = Brushed Bronze
 340 = Brushed Black Chrome
 670 = Matt Black
 700 = Matt White



Tīrīšana (skat. lpp. 22)



Montāžas piemēri (skat. lpp. 21)



Sigurnosne napomene

- ⚠ Prilikom montaže se radi sprečavanja prignječenja i posekotina moraju nositi rukavice.

Instrukcije za montažu

- Pre montaže se mora proveriti da li je proizvod oštećen pri transportu. Nakon ugradnje se ne priznaju nikakve reklamacije koje se odnose na površinska i transportna oštećenja.
- Vodovi i armatura moraju biti postavljeni, isprani i testirani prema važećim normama.
- Treba se pridržavati propisa koji u određenim zemljama važe za instalacije.

Tehnički podaci

Radni pritisak:	maks. 1 MPa
Preporučeni radni pritisak:	0,1 - 0,5 MPa
Probni pritisak:	1,6 MPa

(1 MPa = 10 bar = 147 PSI)

Temperatura vruće vode: maks. 60°C

Slobodan protok na 0,3 MPa:: 25,2 l/min

Termička dezinfekcija: 70°C / 4 min

Proizvod je koncipiran isključivo za pijaću vodu!

Opis simbola

-  Nemojte koristiti silikon koji sadrži sircetnu kiselinu!

Održavanje (vidi stranu 21)

Ispravno funkcionisanje nepovratnog ventila se mora redovno proveravati prema standardu EN 806-5 i u skladu s važećim nacionalnim ili regionalnim propisima (najmanje jednom godišnje).

Mere (vidi stranu 20)

Rezervni delovi (vidi stranu 23)

XXX = Oznake boja
000 = Hrom
140 = Brushed Bronze
340 = Brushed Black Chrome
670 = Matt Black
700 = Matt White

Čišćenje (vidi stranu 22)

Primeri montaže (vidi stranu 21)

Sikkerhetshenvisninger

- ⚠ Bruk hansker under montasjen for å unngå klem- og kuttskader.

Montagehenvisninger

- Før montasjen skal produktet sjekkes for transportskader. Etter monteringen aksepteres ikke noen transport- eller overflateskader.
- Ledningene og armaturen skal monteres, spyles og sjekkes iht. de gyldige normer.
- Gjeldende retningslinjer for rørleggerarbeid i de enkelte land skal følges.

Tekniske data

Driftstrykk	maks. 1 MPa
Anbefalt driftstrykk:	0,1 - 0,5 MPa
Prøvetrykk	1,6 MPa

(1 MPa = 10 bar = 147 PSI)

Varmtvannstemperatur maks. 60°C

Fri gjennomstrømning ved 0,3 MPa:: 25,2 l/min

Termisk desinfisering: 70°C / 4 min

Produktet er utelukkende designet for drikkevann!

Symbolbeskrivelse

-  Ikke bruk silikon som inneholder eddiksyre!

Vedlikehold (se side 21)

Funksjonen til returløpssperren skal iht. EN 806-5 og i samsvar med de nasjonale og lokale forskrifter sjekkes regelmessig (minst en gang i året).

Mål (se side 20)

Servicedeler (se side 23)

XXX = Fargekode
000 = Krom
140 = Brushed Bronze
340 = Brushed Black Chrome
670 = Matt Black
700 = Matt White

Rengjøring (se side 22)

Montasje-eksempel (se side 21)



Указания за безопасност

△ При монтажа трябва да се носят ръкавици, за да се избегнат наранявания поради притискане или порязване.

Указания за монтаж

- Преди монтажа продуктът трябва да се провери за транспортни щети. След монтажа не се признават транспортни или повърхностни щети.
- Тръбопроводите и арматурата трябва да се монтира, промият и проверят в съответствие с валидните норми.
- Трябва да бъдат спазвани валидните в съответните страни предписания за инсталиране.

Технически данни

Работно налягане: макс. 1 МПа
 Препоръчително работно налягане: 0,1 - 0,5 МПа
 Контролно налягане: 1,6 МПа
 (1 МПа = 10 bar = 147 PSI)
 Температура на горещата вода: макс. 60°C
 Свободен поток при 0,3 МПа: 25,2 л/мин
 Термична дезинфекция: 70°C / 4 мин
 Продуктът е разработен само за питейна вода!

Описание на символите



Не използвайте силикон, съдържащ оцетна киселина!



Поддръжка (вижте стр. 21)

Съгласно EN 806-5 функционирането на приспособленията за предотвратяване на обратния поток трябва редовно да се проверява в съответствие с националните или регионални изисквания (поне веднъж годишно).



Размери (вижте стр. 20)



Сервизни части (вижте стр. 23)

XXX = Цветово кодиране
 000 = Хром
 140 = Brushed Bronze
 340 = Brushed Black Chrome
 670 = Matt Black
 700 = Matt White



Почистване (вижте стр. 22)



Примери за монтаж (вижте стр. 21)



安全上の注意

△ 施工の際は手を挟んだり怪我をしないように、手袋をはめてください。

施工上の注意

- 製品の施工前に輸送でのダメージがないか確認してください。施工後のキズ等のお申し出はお断りさせていただきます。
- 配管と水栓は、関連法規に従って施工、洗浄、および試験を行ってください。
- 施工行う地域に適用される関連法規をお守りください。

技術資料

使用圧力: 最大 1 МПа
 推奨使用水圧: 0,1 - 0,5 МПа
 耐圧試験圧力: 1,6 МПа
 (1 МПа = 10 bar = 147 PSI)
 給湯温度: 最大 60°C
 0.3 МПаで何も接続しない時の流量: 25,2 リットル/分
 お湯による高温消毒: 70°C / 4 分
 この製品は飲料水での使用が前提となっています (日本においては水道法に適合する飲料水)!

アイコンの説明



酢酸系シリコンをご使用にならないでください!



メンテナンス (次のページを参照 21)

逆止弁は、EN 806-5に従って定期的 (少なくとも年に1回) に確認をしてください (日本においては関連法規に従ってください)。



寸法 (次のページを参照 20)



スペアパーツ (次のページを参照 23)

XXX = 仕上げ色
 000 = Chrome
 140 = Brushed Bronze
 340 = Brushed Black Chrome
 670 = Matt Black
 700 = Matt White



お手入れ方法 (次のページを参照 22)



施工例 (次のページを参照 21)

**⚠ Udhëzime sigurie**

⚠ Për të evituar lëndimet e pickimeve ose të prerjeve gjatë procesit të montimit duhet që të vishni doreza.

Udhëzime për montimin

- Përpara montimit duhet që produkti të kontrollohet për dëmtim nga transporti. Pas instalimit nuk do të njihet asnjë dëmtim nga transporti ose dëmtim i sipërfaqes.
- Tubacionet dhe rubinetet duhet që të montohen, të shpëlahen dhe të kontrollohen sipas standardeve në fuqi
- Duhet të respektohen linjat udhëzuese të instalimit, të vlefshme për vendet respektive.

Të dhëna teknike

Presioni gjatë punës	maks. 1 MPa
Presioni i rekomanduar:	0,1 - 0,5 MPa
Presioni për provë:	1,6 MPa
	(1 MPa = 10 bar = 147 PSI)
Temperatura e ujit të ngrohtë	maks. 60 °C
Rrjedhja e lirë me 0,3 Mpa::	25,2 l/min
Dezinfektim Termik:	70 °C / 4 min
Produkti është projektuar ekskluzivisht për ujë të pijshëm!	

Përshkrimi i simbolit

Mos përdorni silikon që në përbërje ka acid acetik.

**Mirëmbajtja (shih faqen 21)**

Penguesit e rrjedhjes në drejtim të kundërt duhen kontrolluar rregullisht në bazë të normave EN 806-5 konform normave nacionale dhe regjionale (së paku një herë në vit).

**Përmasat (shih faqen 20)****Pjesët e servisit (shih faqen 23)**

XXX = Kodimi me anë të ngjyrave
000 = Krom
140 = Brushed Bronze
340 = Brushed Black Chrome
670 = Matt Black
700 = Matt White

**Pastrimi (shih faqen 22)****Shembuj të montimit (shih faqen 21)****⚠ تنبيهات الأمان**

⚠ يجب ارتداء قفازات لليد أثناء التركيب لتجنب حدوث أضرار الإنحشار أو الجروح.

تعليمات التركيب

- قبل القيام بعملية التركيب، يجب فحص المنتج للتأكد من خلوّه من أية تلفيات ناتجة عن النقل. بعد القيام بعملية التركيب، لن يتم الاعتراف بوجود أية تلفيات سطحية أو تلفيات ناتجة عن عملية النقل.
- يجب تركيب وغسيل واختبار التوصيلات وخلطات المياه طبقاً للمعايير السارية.
- يجب مراعاة القواعد الخاصة بالتركيب وأعمال السباكة وفقاً للوائح الخاصة بكل بلد.

المواصفات الفنية

ضغط التشغيل:
ضغط التشغيل الموصى به: 0,1 - 0,5 ميغاباسكال
ضغط الاختبار: 1,6 ميغاباسكال
(1 ميغاباسكال = 10 بار = 147 PSI)
الحد الأقصى 60 °C
درجة حرارة الماء الساخن: الحد الأقصى 60 °C
معدل تدفق 0,3 ميغاباسكال:: 25,2 لتر / الدقيقة
تعقيم حراري: 70 °C / 4 دقيقة
المنتج مخصص فقط لماء الشرب!

وصف الرمز

هام! لا تستخدم السليكون الذي يحتوي على أمحاض!

الصيانة (راجع صفحة 21)

يجب فحص صمام عدم الرجوع بصفة منتظمة حسب المواصفة 5-EN 806 وذلك طبقاً للوائح الوطنية أو الإقليمية (مرة واحد سنوياً على الأقل).

أبعاد (راجع صفحة 20)**قطع الغيار (راجع صفحة 23)**

XXX = الألوان
000 = كروم
Brushed Bronze = 140
Brushed Black Chrome = 340
Matt Black = 670
Matt White = 700

التنظيف (راجع صفحة 22)

مثال على التركيب (راجع صفحة 21)

Montimi

(shih faqen 18)

التركيب

(راجع صفحة 18)



Türkçe



Güvenlik uyarıları

⚠ Montaj esnasında ezilme ve kesilme gibi yaralanmaları önlemek için eldiven kullanılmalıdır.

Montaj açıklamaları

- Montaj işleminden önce ürün nakliye hasarları yönünden kontrol edilmelidir. Montaj işleminden sonra nakliye veya yüzey hasarları için sorumluluk üstlenilmemektedir.
- Boruların ve armatürün montajı, yıkanması ve kontrolü geçerli normlara göre yapılmalıdır.
- Ülkelerde geçerli kurulum yönetmeliklerine riayet edilmelidir.

Teknik bilgiler

İşletme basıncı:	azami 1 MPa
Tavsiye edilen işletme basıncı:	0,1 - 0,5 MPa
Kontrol basıncı:	1,6 MPa
	(1 MPa = 10 bar = 147 PSI)
Sıcak su sıcaklığı:	azami 60°C
0,3 MPa serbest akış:	25,2 l/dak
Termik dezenfeksiyon:	70°C / 4 dak
Ürün sadece şebeke suyu için tasarlanmıştır!	

Simge açıklaması



Asetik asit içeren silikon kullanmayın!



Bakım (bakınız sayfa 21)

EN 806-5 ve ulusal standartlar doğrultusunda Çek valfler düzenli olarak kontrol edilmelidir. (en az yılda bir kez)



Ölçüleri (bakınız sayfa 20)



Yedek Parçalar (bakınız sayfa 23)

XXX = Renkler
000 = Krom
140 = Brushed Bronze
340 = Brushed Black Chrome
670 = Matt Black
700 = Matt White



Temizleme (bakınız sayfa 22)



Montaj Örneği (bakınız sayfa 21)

Garanti Belgesi

Üretici veya İthalatçı Firmasının

Unvanı: Hansgrohe Armatür Ltd. Şti
Adresi: Fulya Mahallesi Bahçeler Sokak Efe han 20/C
Mecidiyeköy Şişli İstanbul
Telefonu: (0-212) 273 07 30
Faks: (0-212) 273 07 40
web adresi: www.hansgrohe.com.tr

Malın

Markası: Hansgrohe
Cinsi: Sıhhi tesisat malzemesi
Garanti Süresi: 2 YIL
Azami Tamir Süresi: 20 İş günü

Genel Müdür

Albert Emlek

Satıcı Firmasının:

Unvanı:
Adresi:
Telefonu:
Faks:
e-posta:
Fatura Tarih ve Sayısı:
Marka ve Modeli:
Teslim Tarihi ve Yeri:
Yetkilinin İmzası:
Firmasının Kaşesi:
Bu bölümü, ürünü aldığınız Yetkili Satıcı imzalayacak ve kaşeleyecektir.

Montajı

(bakınız sayfa 18)



Biztonsági utasítások

△ A szerelésnél a zúzódások és vágási sérülések elkerülése érdekében kesztyűt kell viselni.

Szerelési utasítások

- A szerelés előtt ellenőrizni kell, hogy a terméknek nincs-e szállítási sérülése. Beépítés után a szállítási- vagy felületi sérüléseket nem ismerik el.
- A vezetékeket és a csaptelepet az érvényes szabványoknak megfelelően kell felszerelni, öblíteni és ellenőrizni
- Az egyes országokban érvényes installációs irányelveket be kell tartani.

Műszaki adatok

Üzemi nyomás: max. 1 MPa

Ajánlott üzemi nyomás: 0,1 - 0,5 MPa

Nyomáspróba: 1,6 MPa

(1 MPa = 10 bar = 147 PSI)

Forróvíz hőmérséklet: max. 60 °C

Szabad átfolyás 0,3 MPa nyomás esetén: 25,2 l/perc

Termikus fertőtlenítés: 70 °C / 4 perc

A terméket kizárólag ivóvízhez tervezték!

Szimbólumok leírása



Ne használjon ecetsavtartalmú szilikont!



Karbantartás (lásd a oldalon 21)

A visszafolyásgátlók működése a EN 806-5 szabványnak megfelelően, a nemzeti vagy területi rendelkezésekkel összhangban, évente egyszer ellenőrizendő!



Méretet (lásd a oldalon 20)



Tartozékok (lásd a oldalon 23)

XXX = Színkódolás

000 = Króm

140 = Brushed Bronze

340 = Brushed Black Chrome

670 = Matt Black

700 = Matt White



Tisztítás (lásd a oldalon 22)



Szerelési példák (lásd a oldalon 21)

Szerelés

(lásd a oldalon 18) 

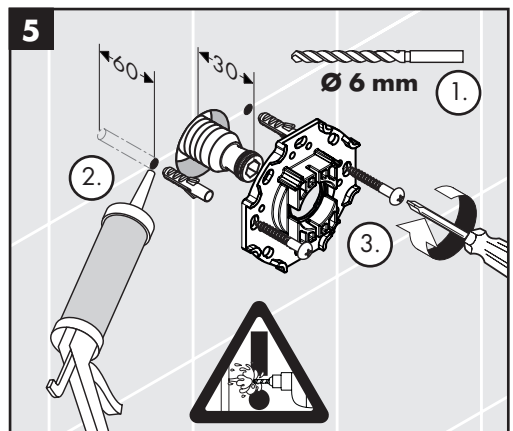
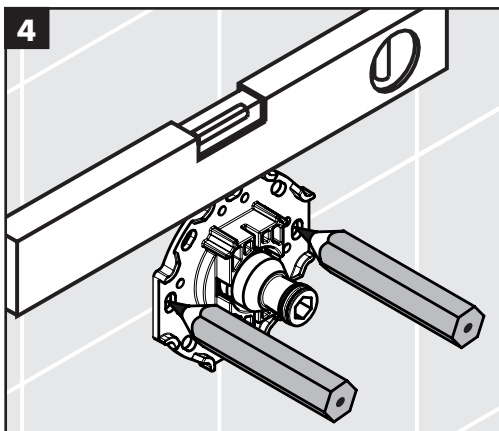
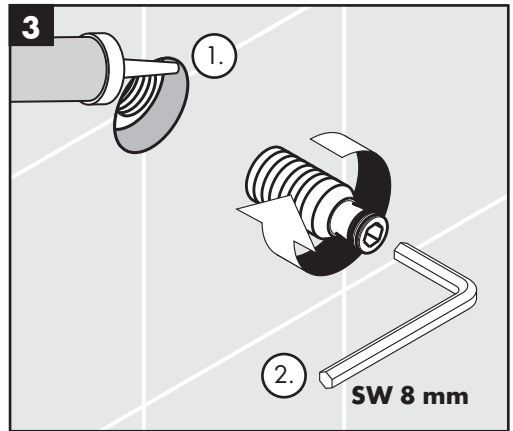
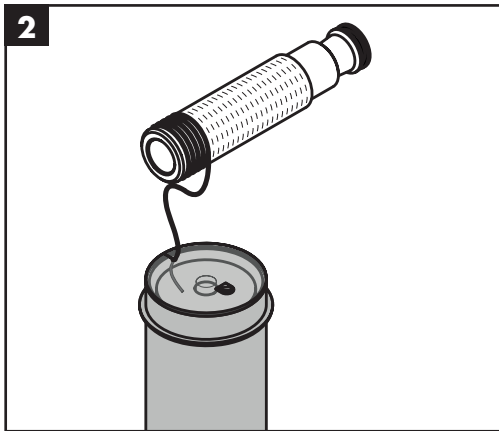
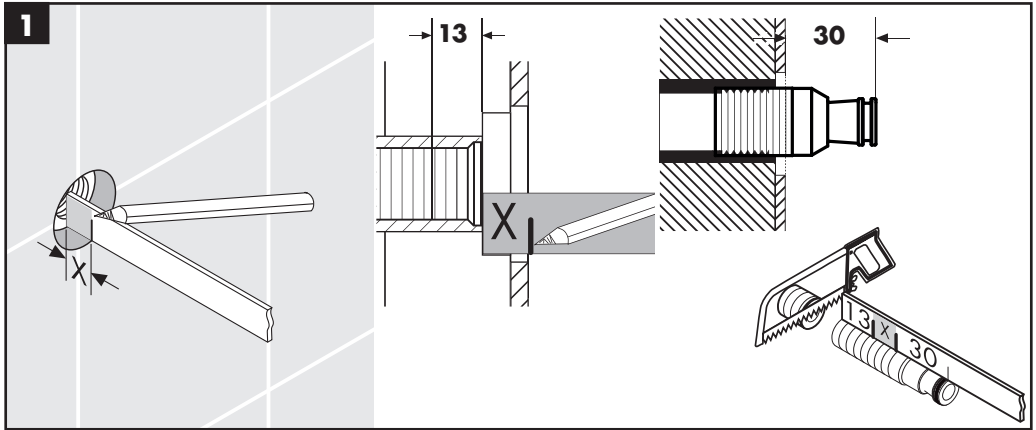

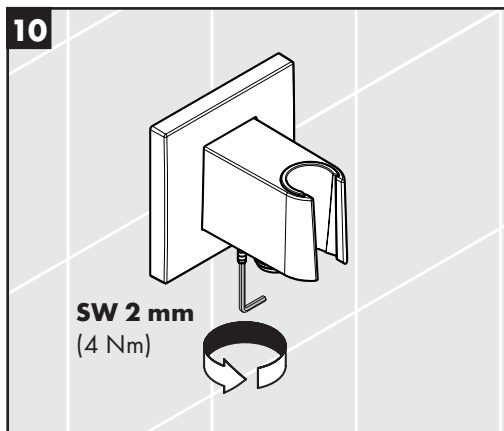
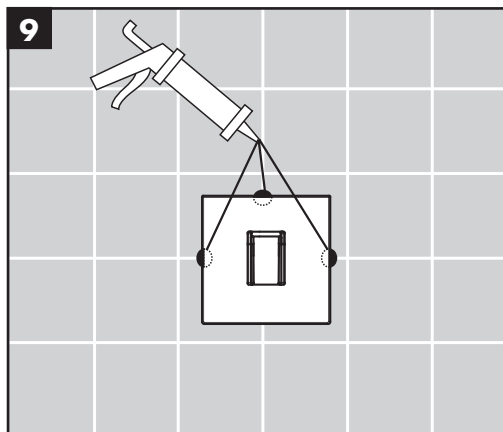
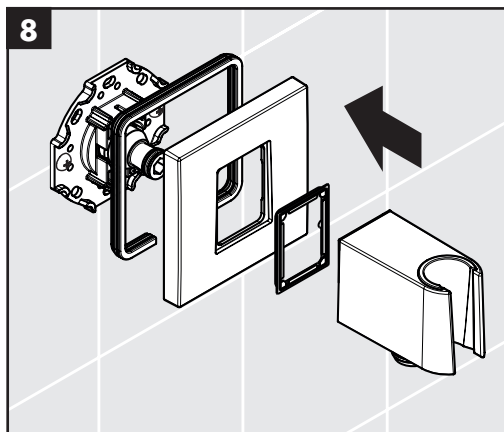
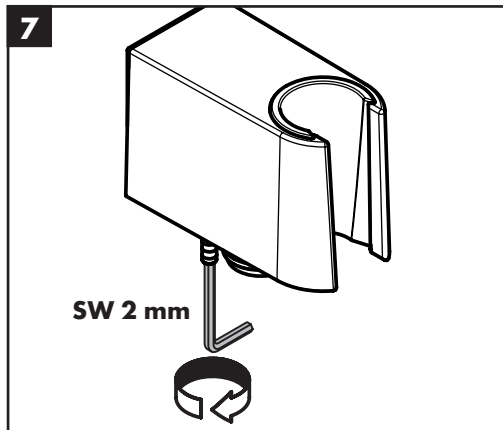
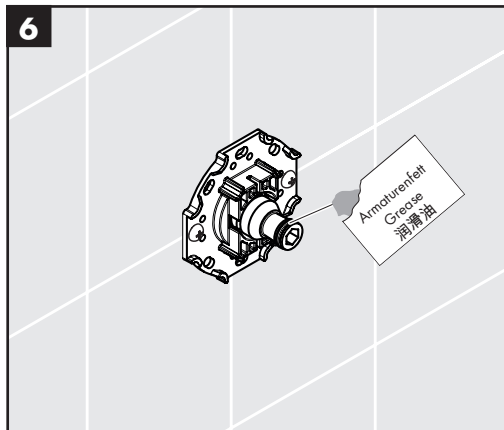



FixFit Q
26887XXX

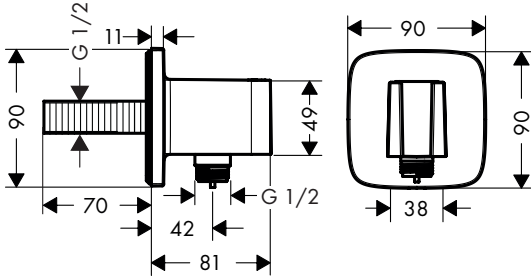

FixFit S
26888XXX

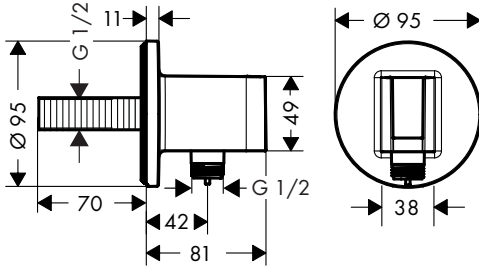

FixFit E
26889XXX

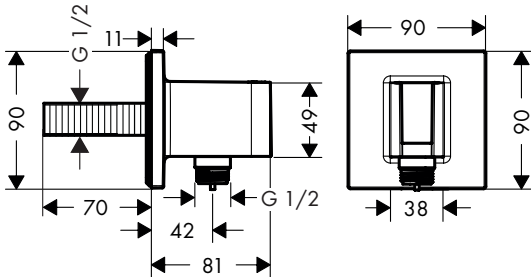

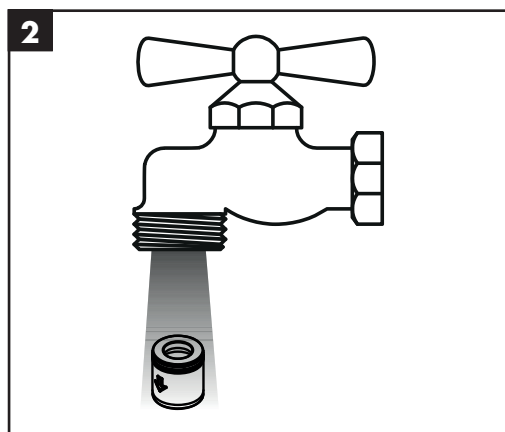
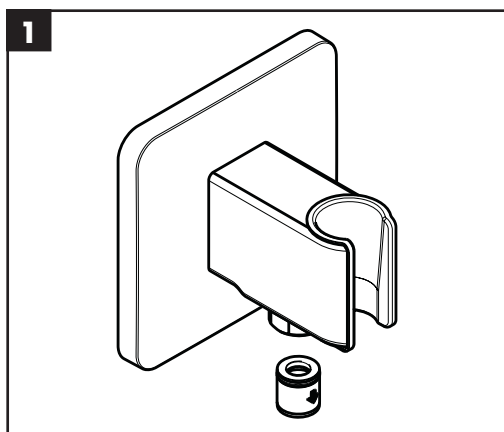
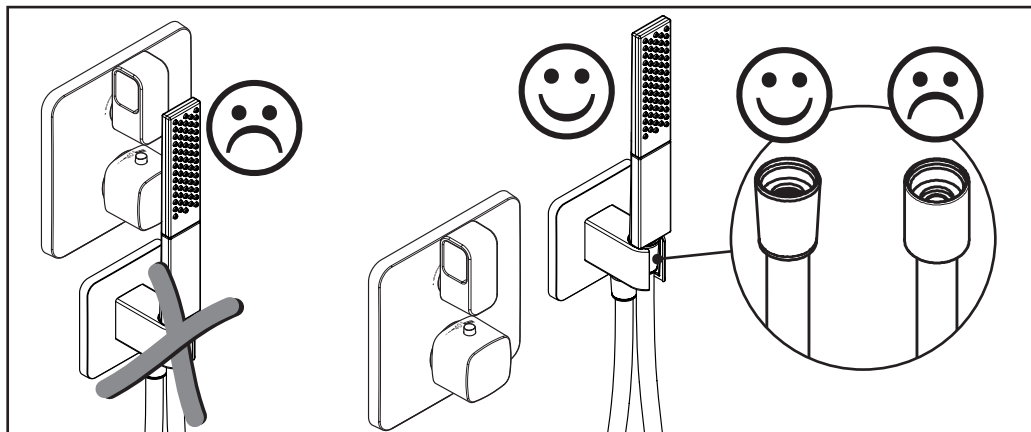



- DE** Reinigungsempfehlung / Garantie / Kontakt
- FR** Recommandation pour le nettoyage / Garanties / Contact
- EN** Cleaning recommendation / Warranty / Contact
- IT** Raccomandazione di pulizia / Garanzia / Contatto
- ES** Recomendaciones para la limpieza / Garantía / Contacto
- NL** Aanbevelingen inzake reiniging / Garantie / Contact
- DK** Rengøringsvejledning / Garanti / Kontakt
- PT** Recomendações de limpeza / Garantia / Contacto
- PL** Zalecenie dotyczące pielęgnacji / Gwarancja / Kontakt
- CS** Doporučení k čištění / Záruka / Kontakt
- SK** Odporúčania pre čistenie / Záruka / Kontakt
- ZH** 清洁指南 / 担保 / 接触
- RU** Рекомендации по очистке / Гарантия / Контакты
- FI** Puhdistussuositus / Takuu / Kosketus
- SV** Rengöringsrekommendationer / Garanti / Contacto
- LT** Valymo rekomendacijos / Garantija / Kontaktai
- HR** Preporuke za čišćenje / Garancija / Kontakt
- TR** Temizleme önerisi / Garanti / Temas
- RO** Recomandări pentru curățare / Garanție / Contact
- EL** Σύσταση καθαρισμού / Εγγύηση / επαφή
- SL** Priporočilo za čiščenje / Garancija / Kontakt
- ET** Puhastussoovitused / Garantii / Kontakt
- LV** Tīrīšanas ieteikumi / Garantija / Kontakti
- SR** Preporuke za čišćenje / Garancija / Kontakt
- NO** Anbefaling for rengjøring / Garanti / Kontakt
- BG** Препоръка за почистване / Гаранция / Контакт
- SQ** Këshilla rreth pastrimit / Garancia / Kontakt
- KO** 세정시 권장사항 / 품질보증 / 접촉
- AR** توصيات التنظيف / الضمان / اتصال
- HU** Tisztítási tanácsok / Garancia / érintkezés
- JP** お手入れの方法 / 保証について / ご連絡先



[www.hansgrohe.com/
cleaning-recommendation](http://www.hansgrohe.com/cleaning-recommendation)

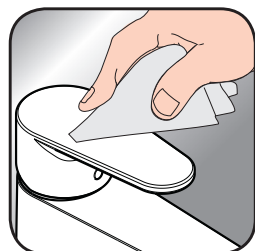

[www.hansgrohe.com/
cleaning-recommendation](http://www.hansgrohe.com/cleaning-recommendation)



[www.hansgrohe.com/
cleaning-recommendation](http://www.hansgrohe.com/cleaning-recommendation)



[www.hansgrohe.com/
cleaning-recommendation](http://www.hansgrohe.com/cleaning-recommendation)

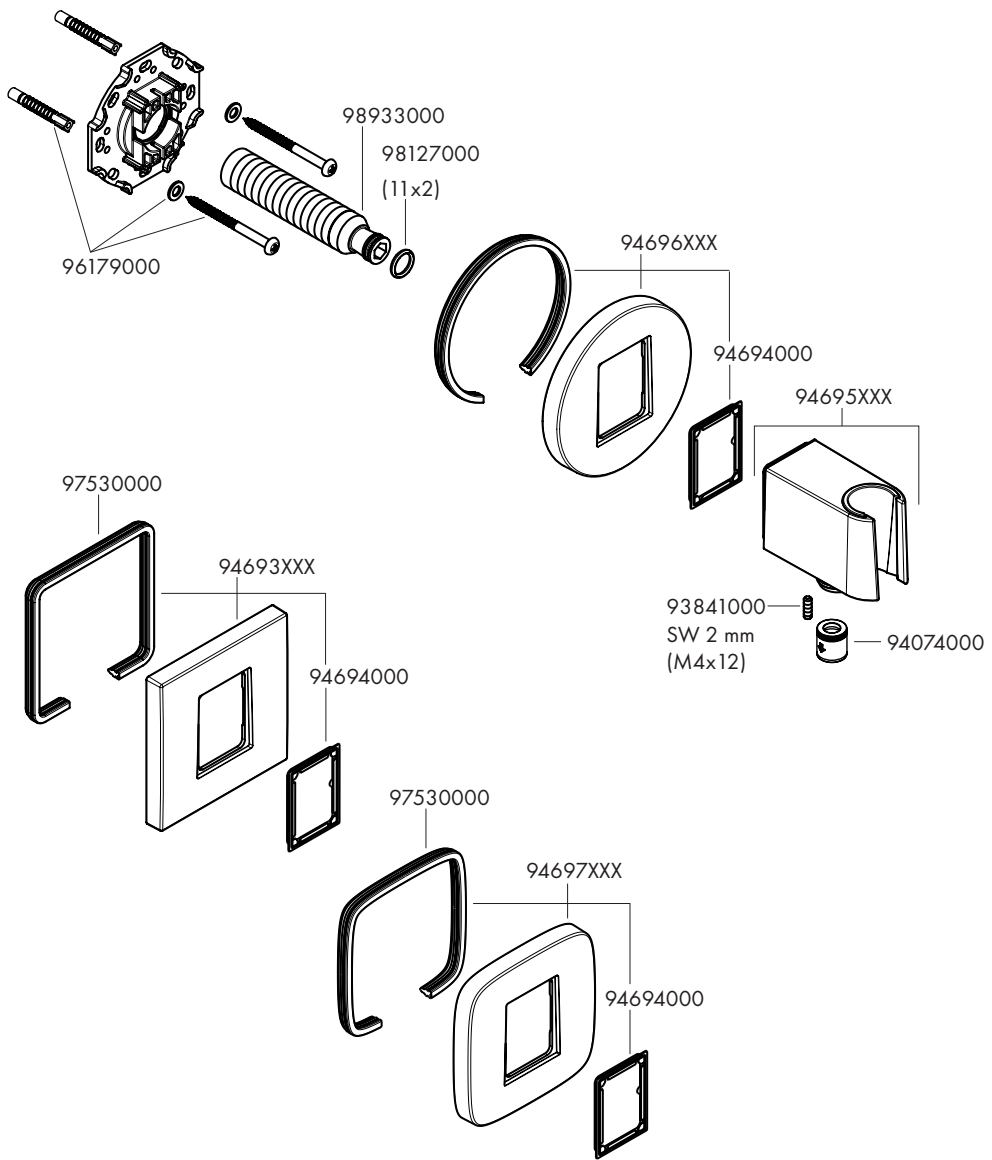

hansgrohe

Hansgrohe · AuestraÙe 5 · 9 · D-77761 Schiltach · Telefon +49 (0) 78 36/51-1282 · Telefax +49 (0) 7836/511440
E-Mail: info@hansgrohe.com · Internet: www.hansgrohe.com

05/2022
9.091.800.01