

# KHDS2

Shut-off kit with mixer, push-button metal hand shower and 100 cm flexible hose

Kit doccia con miscelatore Shut-off, doccia a pulsante in metallo e flessibile 100 cm

Kit de douche Shut-off avec mitigeur, douchette push-button en métal et flexible 100 cm

Shut-off Brauseset mit Mischer, Push-Button Metall-Handbrause und 100 cm Brauseschlauch

# hotbath

italian bathroomware

Hotbath Srl

Via Marco Polo 135/D • I-55049 • Viareggio • Italy  
info@hotbath.it • www.hotbath.it

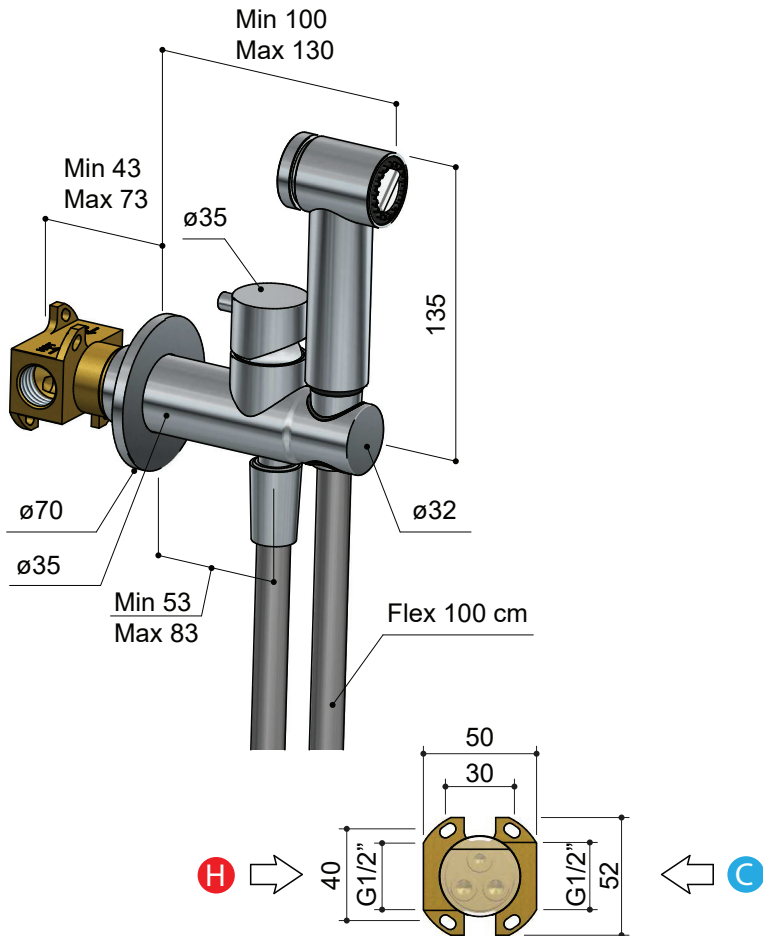

## BEFORE STARTING / PRIMA DI INIZIARE / AVANT DE COMMENCER / VOR DEM START

|                         |                        |                  |            |            |            |                                |
|-------------------------|------------------------|------------------|------------|------------|------------|--------------------------------|
| <p><b>P</b><br/>bar</p> | <p>MAX 5<br/>1 MIN</p> | <p>3<br/>1</p>   | <p>ON</p>  | <p>15s</p> | <p>OFF</p> | <p>FILTER TAPS RECOMMENDED</p> |
| <p><b>T</b><br/>°C</p>  | <p>MAX 80</p>          | <p>60<br/>45</p> | <p>OFF</p> |            |            |                                |

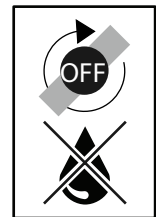
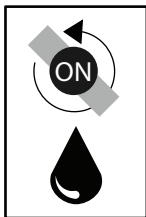
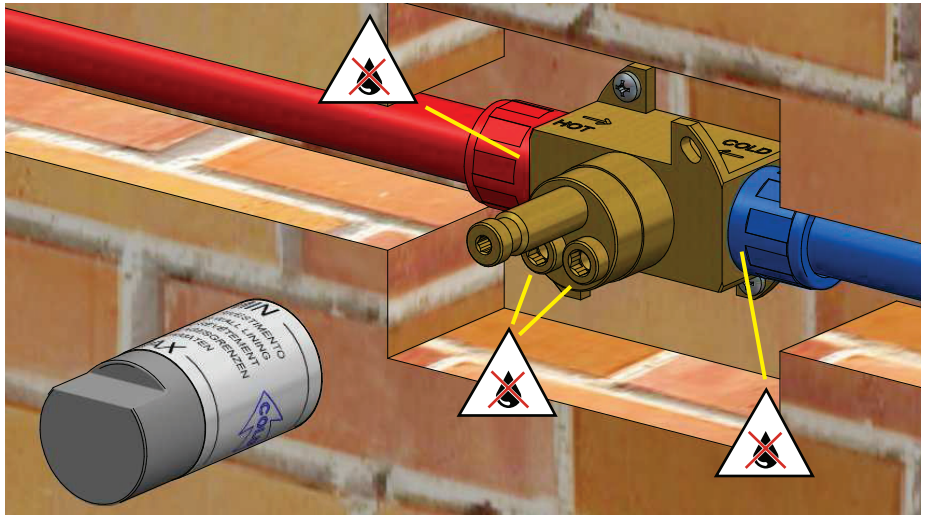
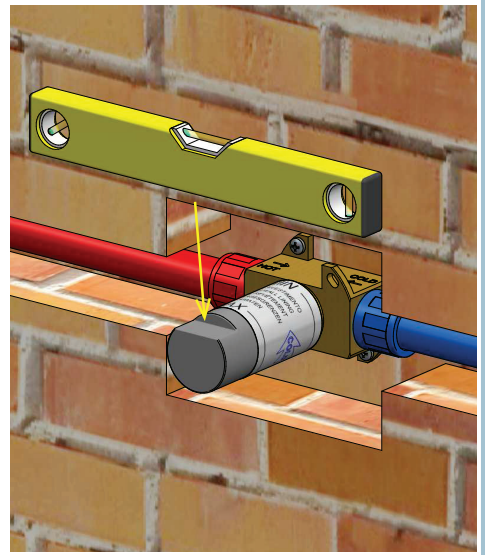
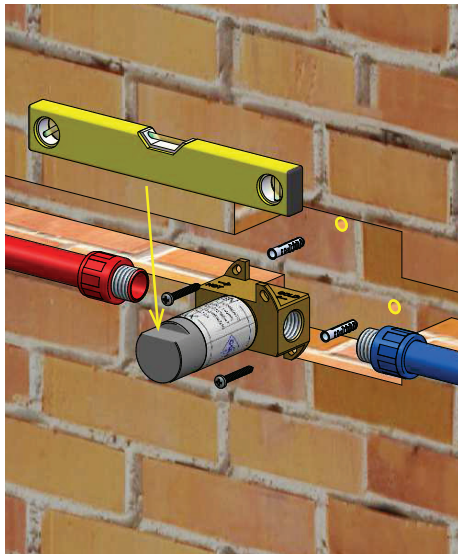

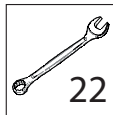
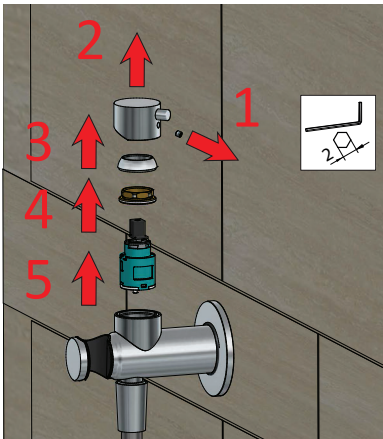
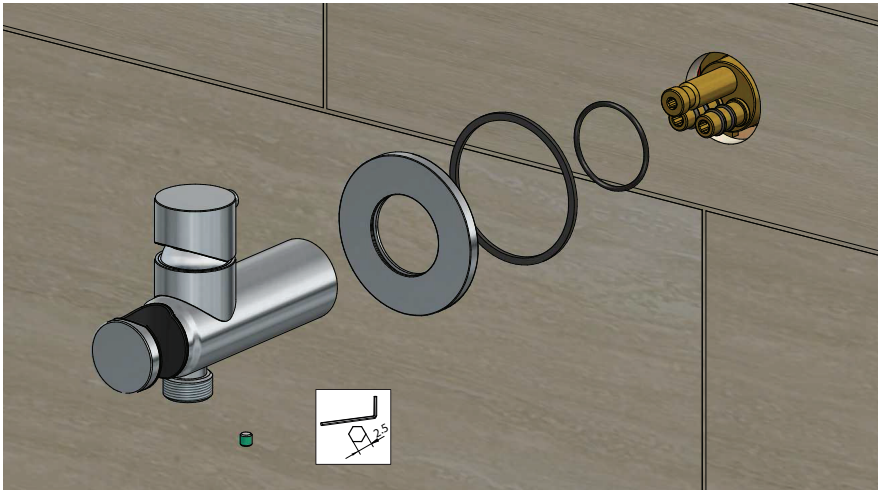
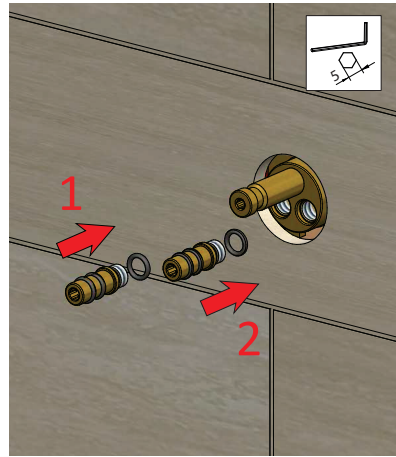
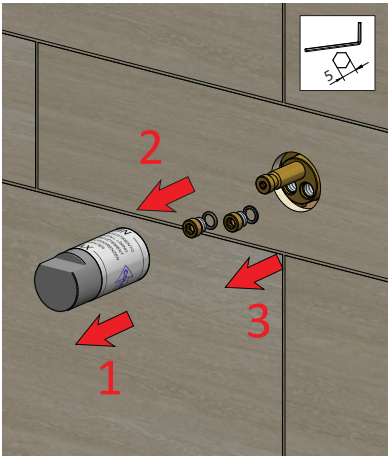

MAX TIGHTENING  
TORQUE  
**10-12 Nm**

# CLEANING / PULIZIA / NETTOYAGE / REINIGUNG

**MAINTENANCE** - Never use for any reason cleaning solutions containing abrasive substances, chloric acids, ammonia, vinegar, bleach, domestic acids, disinfectants, or any type of abrasive pad. Warning: Incorrect cleaning may permanently ruin the surface of the products and in such case the manufacturer may not be held liable for damage.

**MANUTENZIONE** - Non usare mai per qualsiasi motivo soluzioni detergenti contenenti sostanze abrasive, acido clorico, ammoniaca, aceto, candeggina, acidi domestici, disinfettanti o qualsiasi tipo di spugna o panno abrasivo. Attenzione! Una pulizia errata può rovinare in modo permanente la superficie dei prodotti e in tal caso il Produttore non può essere ritenuto responsabile per danni.

**ENTRETIEN** - N'utilisez jamais des solutions de nettoyage contenant substances abrasives, acide chlorique, ammoniac, vinaigre, eau de javel, acides domestiques, désinfectants ou tout type de tissu abrasif. Attention! Un nettoyage in correcte peut endommager de manière permanente la surface des produits et dans ce cas, le Fabricant ne pourra être tenu responsable des dommages.

**WARTUNG** - Verwenden Sie niemals Reinigungslösungen, die Schleifmittel, Hausnatronsaure, Desinfektionsmittel oder andere Arten von Schleifmitteln enthalten. Warnung! Durch eine falsche Reinigung kann die Oberfläche der Produkte dauerhaft beschädigt werden. In diesem Fall ist der Hersteller nicht für Schäden haftbar.

Warning: Incorrect cleaning may permanently ruin the surface of the products and in such case the manufacturer may not be held liable for damage.

|                                  | ✓       |               |                |                   | ✗                         |   | WARNING |
|----------------------------------|---------|---------------|----------------|-------------------|---------------------------|---|---------|
| <b>CR</b><br>CHROME              | WATER ✓ | LIQUID SOAP ✓ | SMOOTH CLOTH ✓ | ABRASIVE SPONGE ✗ | ACID/ABRASIVE DETERGENT ✗ | Inoxidizable plated finish<br>Finitura placcata inossidabile<br>Finition plaquée inoxydable<br>Inoxidierbare plattierte Ausführung  |         |
| <b>GN</b><br>BRUSHED NICKEL      | WATER ✓ | LIQUID SOAP ✓ | SMOOTH CLOTH ✓ | ABRASIVE SPONGE ✗ | ACID/ABRASIVE DETERGENT ✗ | Inoxidizable plated finish<br>Finitura placcata inossidabile<br>Finition plaquée inoxydable<br>Inoxidierbare plattierte Ausführung  |         |
| <b>NI</b><br>BRIGHT NICKEL       | WATER ✓ | LIQUID SOAP ✓ | SMOOTH CLOTH ✓ | ABRASIVE SPONGE ✗ | ACID/ABRASIVE DETERGENT ✗ | Oxidizable plated finish<br>Finitura placcata ossidabile<br>Finition plaquée oxydable<br>Oxidierbare plattierte Ausführung  |         |
| <b>NB</b><br>NATURAL BRASS       | WATER ✓ | LIQUID SOAP ✓ | SMOOTH CLOTH ✓ | ABRASIVE SPONGE ✗ | ACID/ABRASIVE DETERGENT ✗ | Natural metal finish: patina will form over time<br>Finitura di metallo naturale: si formerà una patina nel tempo<br>Finition en métal naturel: une patine se formera avec le temps<br>Natürliche Metallausführung: eine Patina wird sich mit der Zeit bilden                       |         |
| <b>BB</b><br>BRUSHED BRASS       | WATER ✓ | LIQUID SOAP ✓ | SMOOTH CLOTH ✓ | ABRASIVE SPONGE ✗ | ACID/ABRASIVE DETERGENT ✗ | Natural metal finish: patina will form over time<br>Finitura di metallo naturale: si formerà una patina nel tempo<br>Finition en métal naturel: une patine se formera avec le temps<br>Natürliche Metallausführung: eine Patina wird sich mit der Zeit bilden                       |         |
| <b>AB</b><br>AGED BRASS          | WATER ✓ | LIQUID SOAP ✓ | SMOOTH CLOTH ✓ | ABRASIVE SPONGE ✗ | ACID/ABRASIVE DETERGENT ✗ | Aged metal finish: patina will form over time<br>Finitura di metallo invecchiato: si formerà una patina nel tempo<br>Finition en métal vieilli: une patine se formera avec le temps<br>Gealterte Metallausführung: eine Patina wird sich mit der Zeit bilden                        |         |
| <b>WH</b><br>MATT WHITE          | WATER ✓ | LIQUID SOAP ✓ | SMOOTH CLOTH ✓ | ABRASIVE SPONGE ✗ | ACID/ABRASIVE DETERGENT ✗ | Varnished finish: subject to scratches if not properly handled<br>Finitura verniciata: soggetta a deterioramento se non trattata correttamente<br>Finition vernie: sujette aux rayures si ne pas traitée correctement<br>Lackierte Ausführung: Kratzer bei unsachgemäßer Behandlung |         |
| <b>BC</b><br>BRUSHED COPPER      | WATER ✓ | LIQUID SOAP ✓ | SMOOTH CLOTH ✓ | ABRASIVE SPONGE ✗ | ACID/ABRASIVE DETERGENT ✗ | Oxidizable plated finish<br>Finitura placcata ossidabile<br>Finition plaquée oxydable<br>Oxidierbare plattierte Ausführung  |         |
| <b>RG</b><br>ROSE GOLD           | WATER ✓ | LIQUID SOAP ✓ | SMOOTH CLOTH ✓ | ABRASIVE SPONGE ✗ | ACID/ABRASIVE DETERGENT ✗ | Plated finish: subject to scratches if not properly handled<br>Finitura placcata: soggetta a deterioramento se non trattata correttamente<br>Finition plaquée: sujette aux rayures si ne pas traitée correctement<br>Plattierte Ausführung: Kratzer bei unsachgemäßer Behandlung    |         |
| <b>BL</b><br>MATT BLACK          | WATER ✓ | LIQUID SOAP ✓ | SMOOTH CLOTH ✓ | ABRASIVE SPONGE ✗ | ACID/ABRASIVE DETERGENT ✗ | Varnished finish: subject to scratches if not properly handled<br>Finitura verniciata: soggetta a deterioramento se non trattata correttamente<br>Finition vernie: sujette aux rayures si ne pas traitée correctement<br>Lackierte Ausführung: Kratzer bei unsachgemäßer Behandlung |         |
| <b>AI</b><br>AGED IRON           | WATER ✓ | LIQUID SOAP ✓ | SMOOTH CLOTH ✓ | ABRASIVE SPONGE ✗ | ACID/ABRASIVE DETERGENT ✗ | Plated finish: subject to scratches if not properly handled<br>Finitura placcata: soggetta a deterioramento se non trattata correttamente<br>Finition plaquée: sujette aux rayures si ne pas traitée correctement<br>Plattierte Ausführung: Kratzer bei unsachgemäßer Behandlung    |         |
| <b>BK</b><br>BLACK CHROME        | WATER ✓ | LIQUID SOAP ✓ | SMOOTH CLOTH ✓ | ABRASIVE SPONGE ✗ | ACID/ABRASIVE DETERGENT ✗ | Plated finish: subject to scratches if not properly handled<br>Finitura placcata: soggetta a deterioramento se non trattata correttamente<br>Finition plaquée: sujette aux rayures si ne pas traitée correctement<br>Plattierte Ausführung: Kratzer bei unsachgemäßer Behandlung    |         |
| <b>BBP</b><br>BRUSHED BRASS PVD  | WATER ✓ | LIQUID SOAP ✓ | SMOOTH CLOTH ✓ | ABRASIVE SPONGE ✗ | ACID/ABRASIVE DETERGENT ✗ | Inoxidizable PVD finish<br>Finitura inossidabile in PVD<br>Finition PVD inoxydable<br>Inoxidierbare PVD-Ausführung  |         |
| <b>BCP</b><br>BRUSHED COPPER PVD | WATER ✓ | LIQUID SOAP ✓ | SMOOTH CLOTH ✓ | ABRASIVE SPONGE ✗ | ACID/ABRASIVE DETERGENT ✗ | Inoxidizable PVD finish<br>Finitura inossidabile in PVD<br>Finition PVD inoxydable<br>Inoxidierbare PVD-Ausführung  |         |
| <b>NBP</b><br>NATURAL BRASS PVD  | WATER ✓ | LIQUID SOAP ✓ | SMOOTH CLOTH ✓ | ABRASIVE SPONGE ✗ | ACID/ABRASIVE DETERGENT ✗ | Inoxidizable PVD finish<br>Finitura inossidabile in PVD<br>Finition PVD inoxydable<br>Inoxidierbare PVD-Ausführung  |         |