

<b>DE</b>	Gebrauchsanleitung / Montageanleitung	<b>2</b>
<b>FR</b>	Mode d'emploi / Instructions de montage	<b>3</b>
<b>EN</b>	Instructions for use / assembly instructions	<b>4</b>
<b>IT</b>	Istruzioni per l'uso / Istruzioni per Installazione	<b>5</b>
<b>ES</b>	Modo de empleo / Instrucciones de montaje	<b>6</b>
<b>NL</b>	Gebruiksaanwijzing / Handleiding	<b>7</b>
<b>DK</b>	Brugsanvisning / Monteringsvejledning	<b>8</b>
<b>PT</b>	Instruções para uso / Manual de Instalação	<b>9</b>
<b>PL</b>	Instrukcja obsługi / Instrukcja montażu	<b>10</b>
<b>CS</b>	Návod k použití / Montážní návod	<b>11</b>
<b>SK</b>	Návod na použitie / Montážny návod	<b>12</b>
<b>ZH</b>	用户手册 / 组装说明	<b>13</b>
<b>RU</b>	Руководство пользователя / Инструкция по монтажу	<b>14</b>
<b>HU</b>	Használati útmutató / Szerelési útmutató	<b>15</b>
<b>FI</b>	Käyttöohje / Asennusohje	<b>16</b>
<b>SV</b>	Bruksanvisning / Monteringsanvisning	<b>17</b>
<b>LT</b>	Vartotojo instrukcija / Montavimo instrukcijos	<b>18</b>
<b>HR</b>	Upute za uporabu / Uputstva za instalaciju	<b>19</b>
<b>TR</b>	Kullanım kılavuzu / Montaj kılavuzu	<b>20</b>
<b>RO</b>	Manual de utilizare / Instrucțiuni de montare	<b>21</b>
<b>EL</b>	Οδηγίες χρήσης / Οδηγία συναρμολόγησης	<b>22</b>
<b>SL</b>	Navodilo za uporabo / Navodila za montažo	<b>23</b>
<b>ET</b>	Kasutusjuhend / Paigaldusjuhend	<b>24</b>
<b>LV</b>	Lietošanas pamācība / Montāžas instrukcija	<b>25</b>
<b>SR</b>	Uputstvo za upotrebu / Uputstvo za montažu	<b>26</b>
<b>NO</b>	Bruksanvisning / Montasjeveiledning	<b>27</b>
<b>BG</b>	Инструкция за употреба / Ръководство за монтаж	<b>28</b>
<b>SQ</b>	Udhëzuesi i përdorimit / Udhëzime rreth montimit	<b>29</b>
<b>AR</b>	دليل الاستخدام / تعليمات التجميع	<b>30</b>

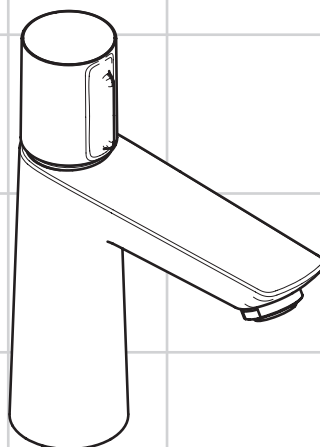

**Talis Select E 110**  
71750000 / 71751000



## Veiligheidsinstructies

- ⚠ Bij de montage moeten ter voorkoming van knel- en snijwonden handschoenen worden gedragen.
- ⚠ Het douchesysteem mag alleen voor het wassen, hygiënische doeleinden en voor de lichaamreiniging worden gebruikt.
- ⚠ Grote drukverschillen tussen de koud- en warmwater-toevoer dienen vermeden te worden.

## Montage-instructies

- Vóór de montage moet het product gecontroleerd worden op transportschade. Na de inbouw wordt geen transport- of oppervlakteschade meer aanvaard.
- De leidingen en armaturen moeten gemonteerd, gespoeld en gecontroleerd worden volgens de geldige normen.
- De in de overeenkomstige landen geldende installatie-richtlijnen moeten nageleefd worden.
- De uitlaatklep mag enkel gebruikt worden voor het reglementaire gebruik. Het bevestigen van andere voorwerpen, bv. een halfzuil op de uitlaatklep is niet toegestaan.
- Wanneer problemen optreden bij doorloopgeisers of wanneer een grotere waterdoorvoer gewenst is, kan de EcoSmart® (doorstroombegrenzer) die achter de perlator is gemonteerd, makkelijk verwijderd worden.

## Technische gegevens

**Armatuur standaard met EcoSmart®** (doorstroombegrenzer)

Werkdruk: max.	max. 1 MPa
Aanbevolen werkdruk:	0,1 - 0,5 MPa
Getest bij:	1,6 MPa
(1 MPa = 10 bar = 147 PSI)	
Temperatuur warm water:	max. 70 °C
Aanbevolen warm water temp.:	65 °C
Thermische desinfectie:	max. 70 °C / 4 min

Het product is uitsluitend ontworpen voor drinkwater!

## Symboolbeschrijving



Gebruik geen zuurhoudende silicone!



**Instellen** (zie blz. 34)

Instellen van de warmwaterbegrenzing. In combinatie met een doorstromer is een warmwaterblokkering niet aanbevelenswaardig.



**Maten** (zie blz. 36)



**Doorstroomdiagram**

(zie blz. 36)



**Bediening** (zie blz. 37)

Hansgrohe raadt aan om 's morgens na langere stagnatietijden de eerste halve liter niet als drinkwater te gebruiken.



**Onderhoud** (zie blz. 38)



**Service onderdelen** (zie blz. 39)



**Toebehoren** (behoort niet tot het leveringspakket)

montagesleutel #58085000



Kit



dichting #98996000



**Reinigen** (zie bijgevoegde brochure)

 **Montage zie blz. 31**

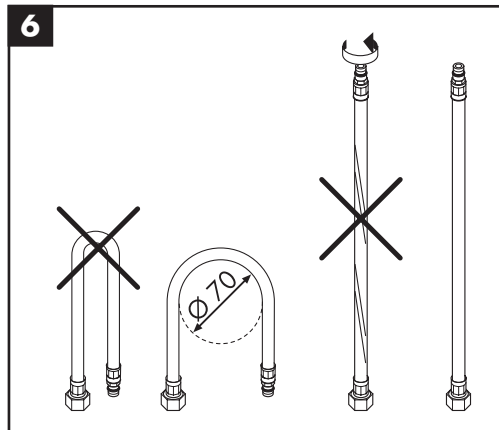
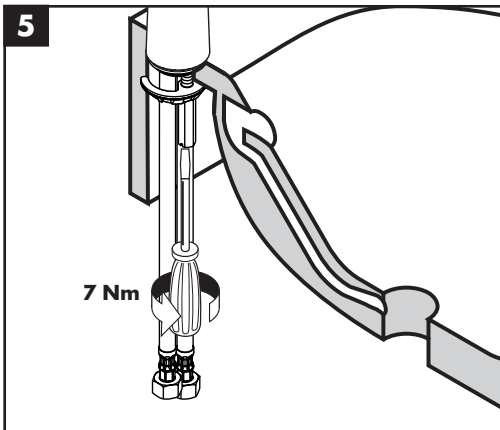
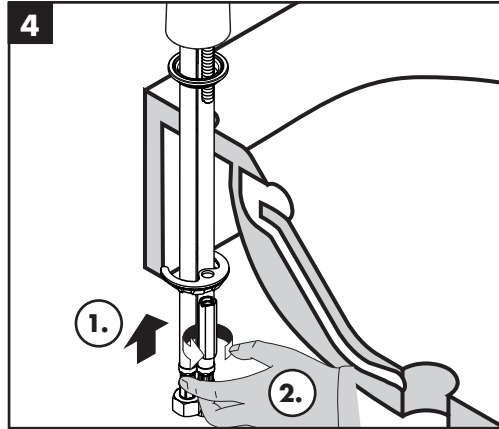
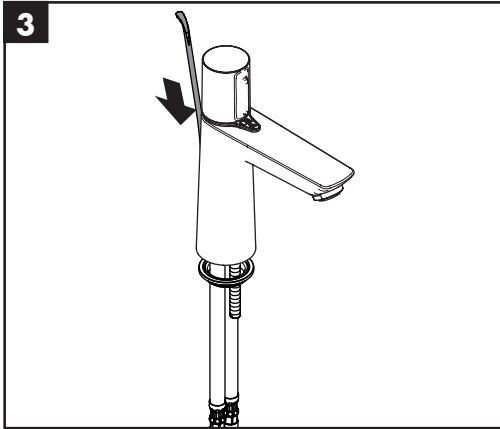
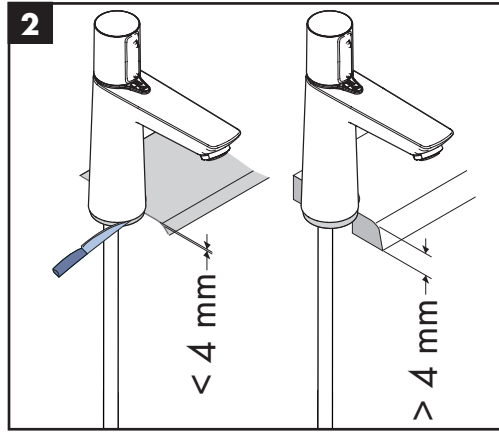
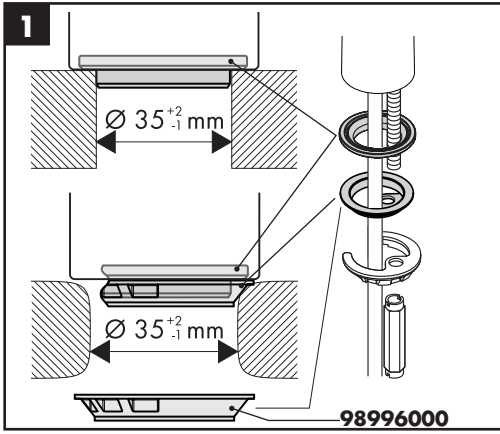

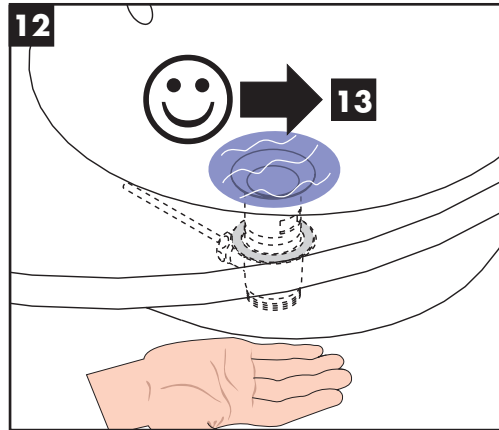
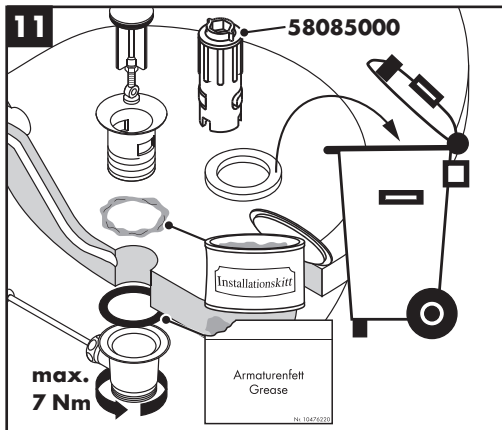
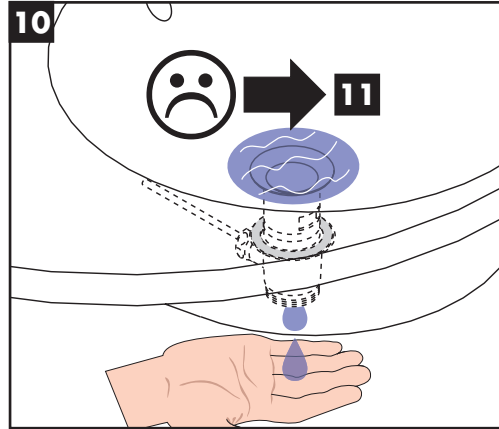
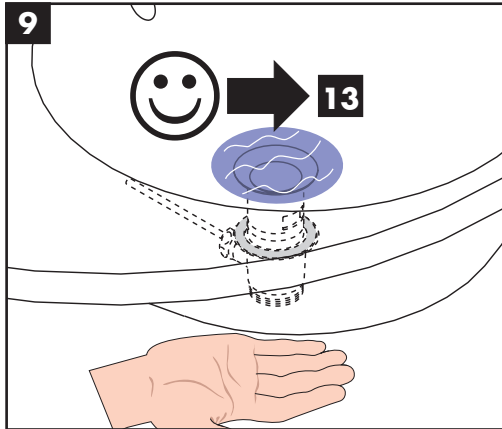
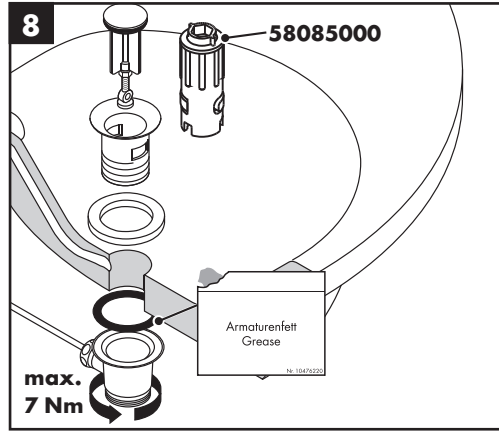
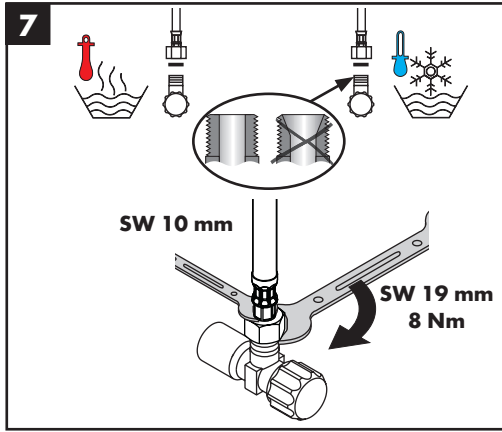

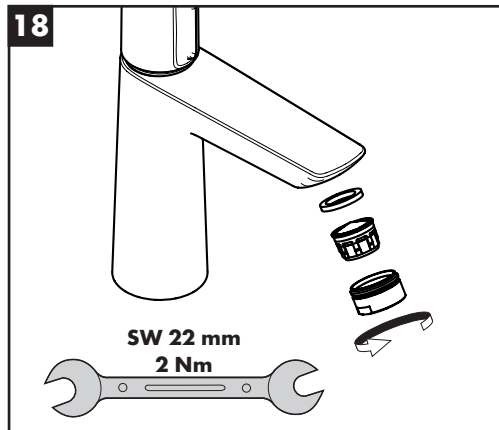
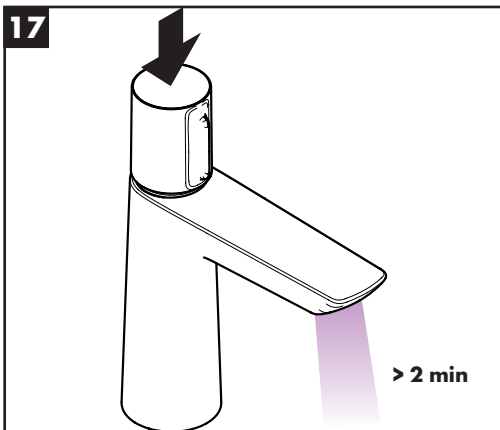
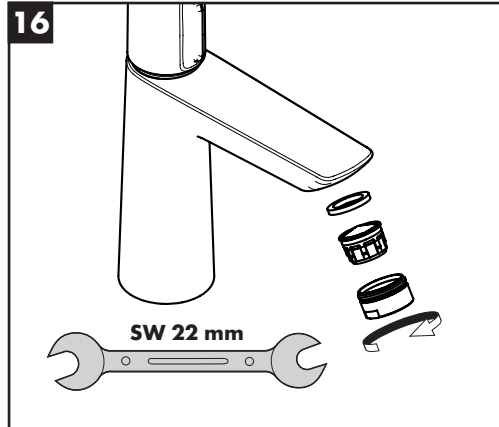
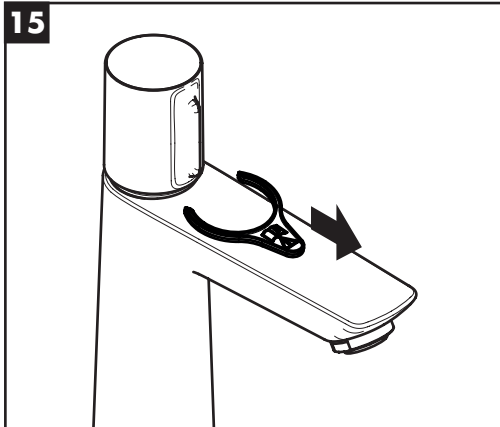
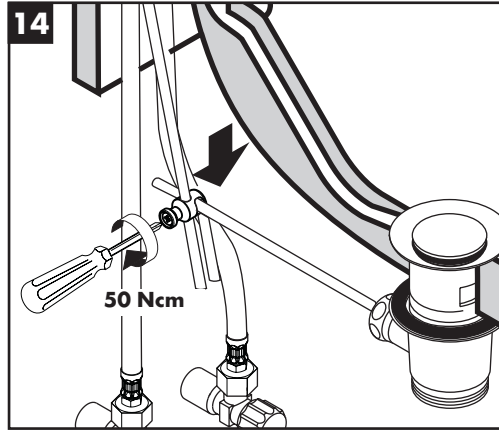
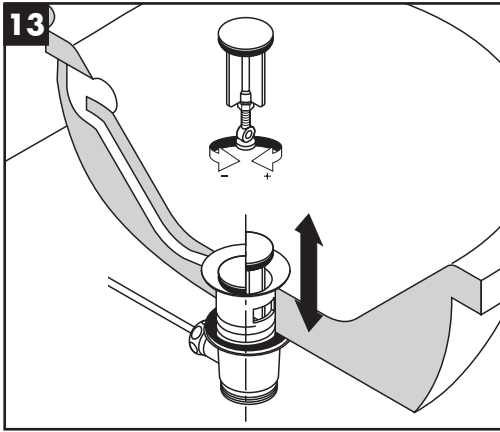



60 °C

10 °C

0,3 МПа  
0,3 МПа  
0,3 میجایسکال

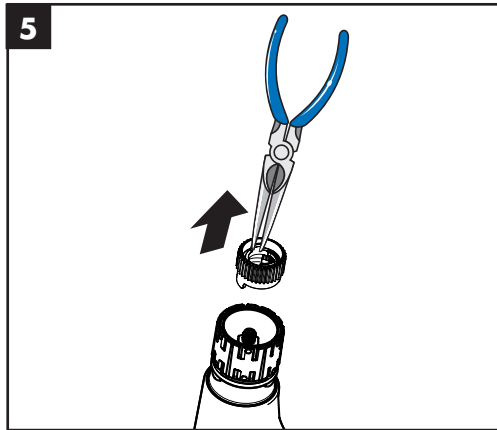
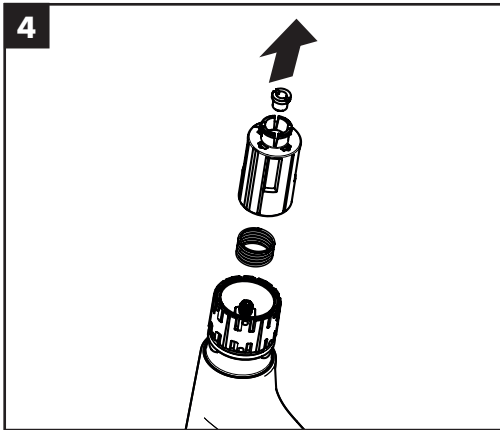
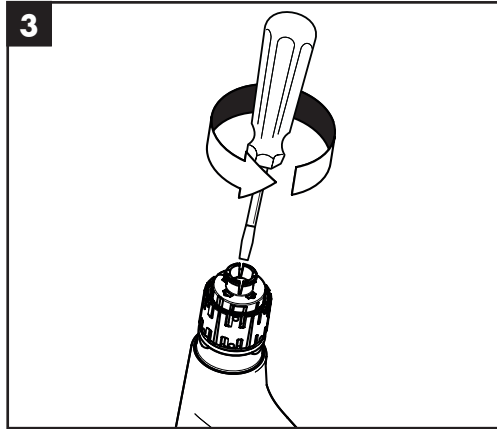
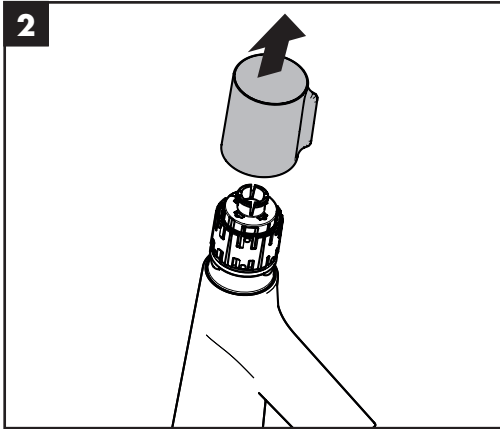
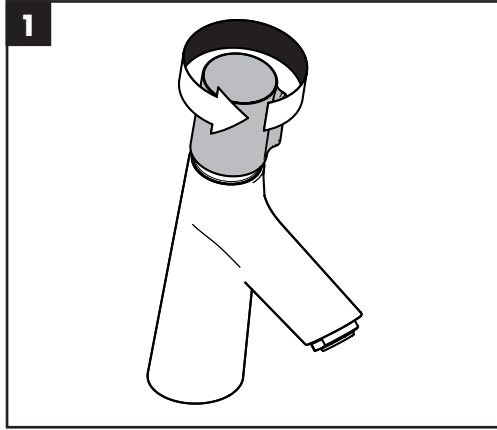

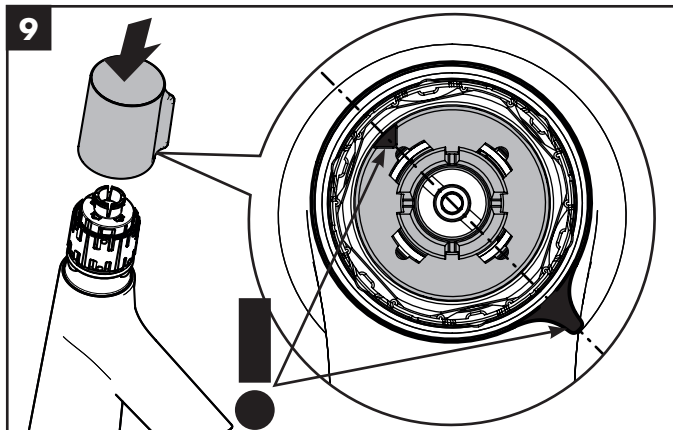
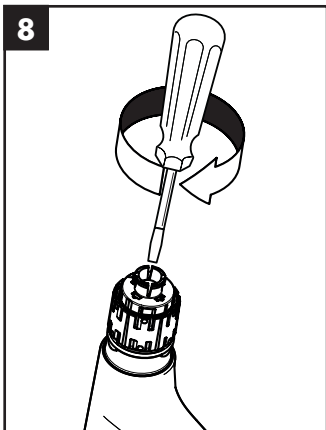
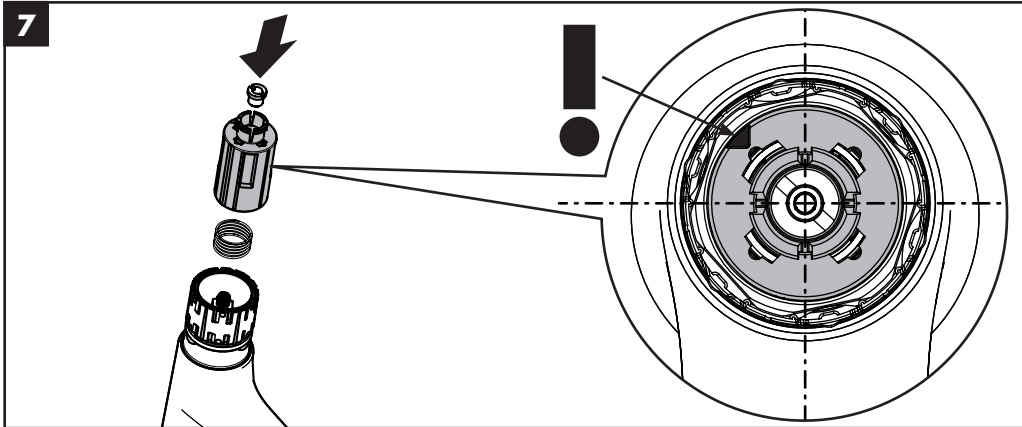
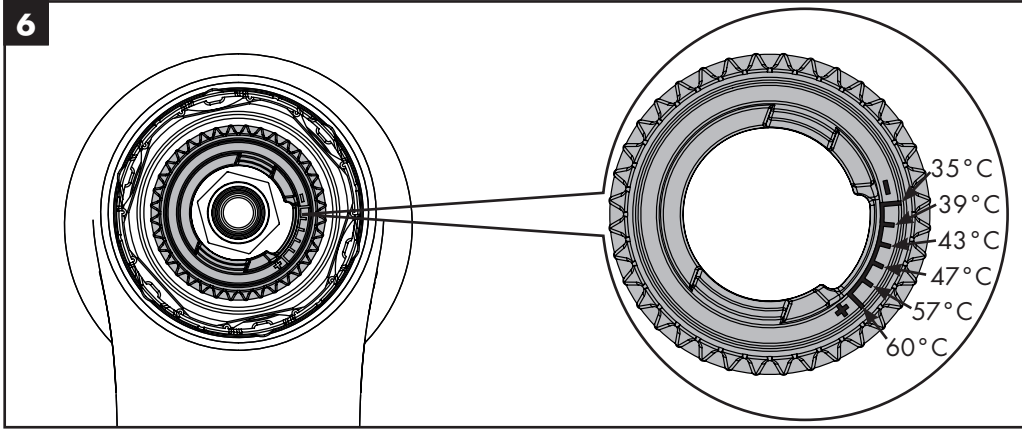

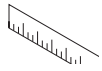

Talis Select E 71750000 / 71751000

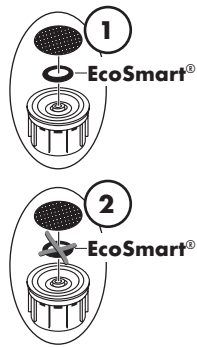
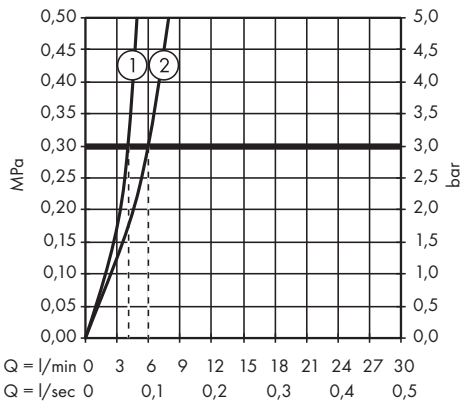
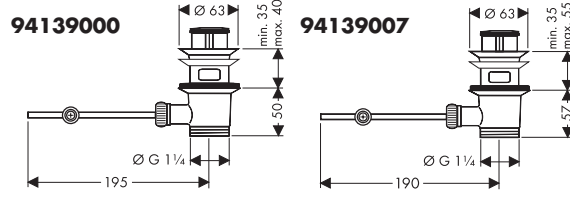
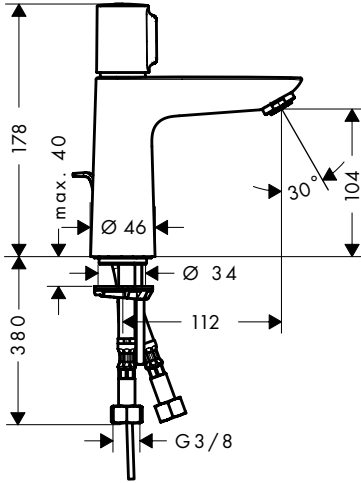



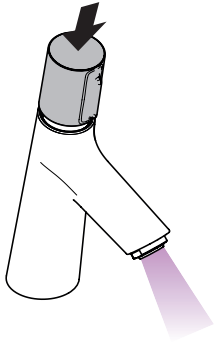

öffnen / ouvert / open / aperto /  
abierto / open / åbne / abrir /  
otworzyć / otevřít / otvoriť / 开 /  
открыть / nyitás / avaaminen /  
öppna / atidaryti / Otvaranje /  
açmak / deschide / ανοικτό /  
odpreti / avage / atvērt /  
otvoriti / åpne / отварање /  
habe / فتح

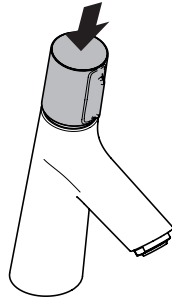

schließen / fermé / close /  
chiudere / cerrar / sluiten /  
lukke / fechar / zamknąć /  
zavřít / uzavrieť / 关 / закрыть /  
bezárás / sulkeminen / stänga /  
uždaryti / Zatvaranje / kapatmak /  
închide / κλειστό / zapreti /  
sulgege / aizvērt / zatvori /  
lukke / затварање / mbylle /  
إغلاق

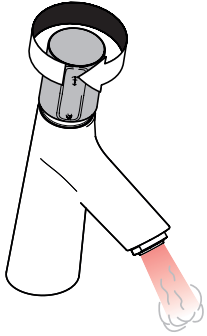

warm / chaud / hot /  
caldo / caliente / warm /  
varmt / quente / ciepła /  
teplá / teplá / 热 / горячая /  
meleg / lämmin / varmt /  
karštas / Vruća voda / sıcak /  
cald / ζεστό / toplo / kuum /  
karsts / topla / varm / тепло /  
i ngrohtë / ساخن

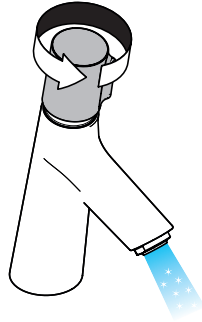

kalt / froid /  
cold / freddo / frío / koud /  
koldt / fria / zimna / studená /  
studená / 冷 / холодная /  
hideg / kylmä / kallt / šaltas /  
Hladno / soğuk / rece /  
κρύο / mrzlo / külm / auksts /  
hladno / kaldt / студено / i  
ftohtë / بارد

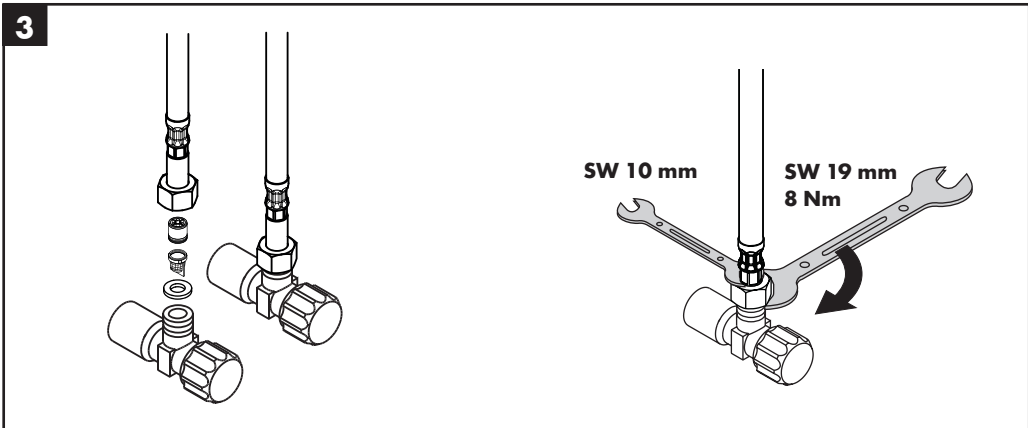
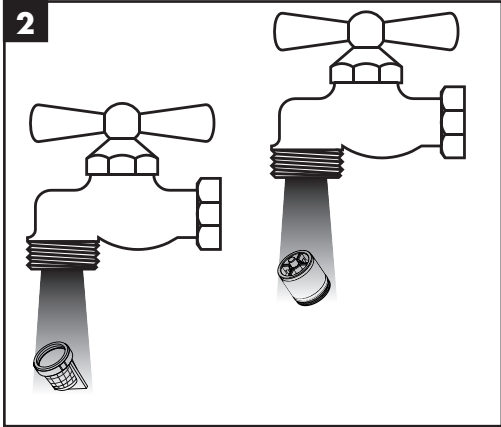
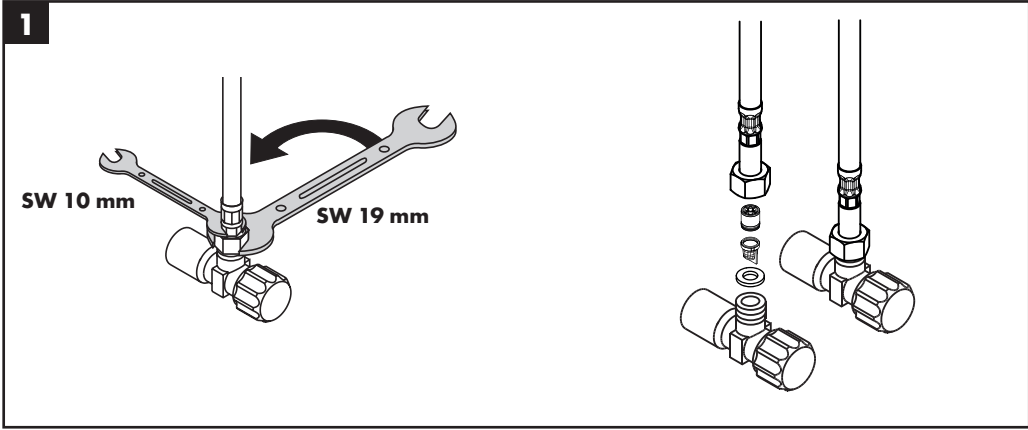

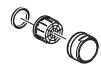

**Talis Select E 110**  
71750000 / 71751000

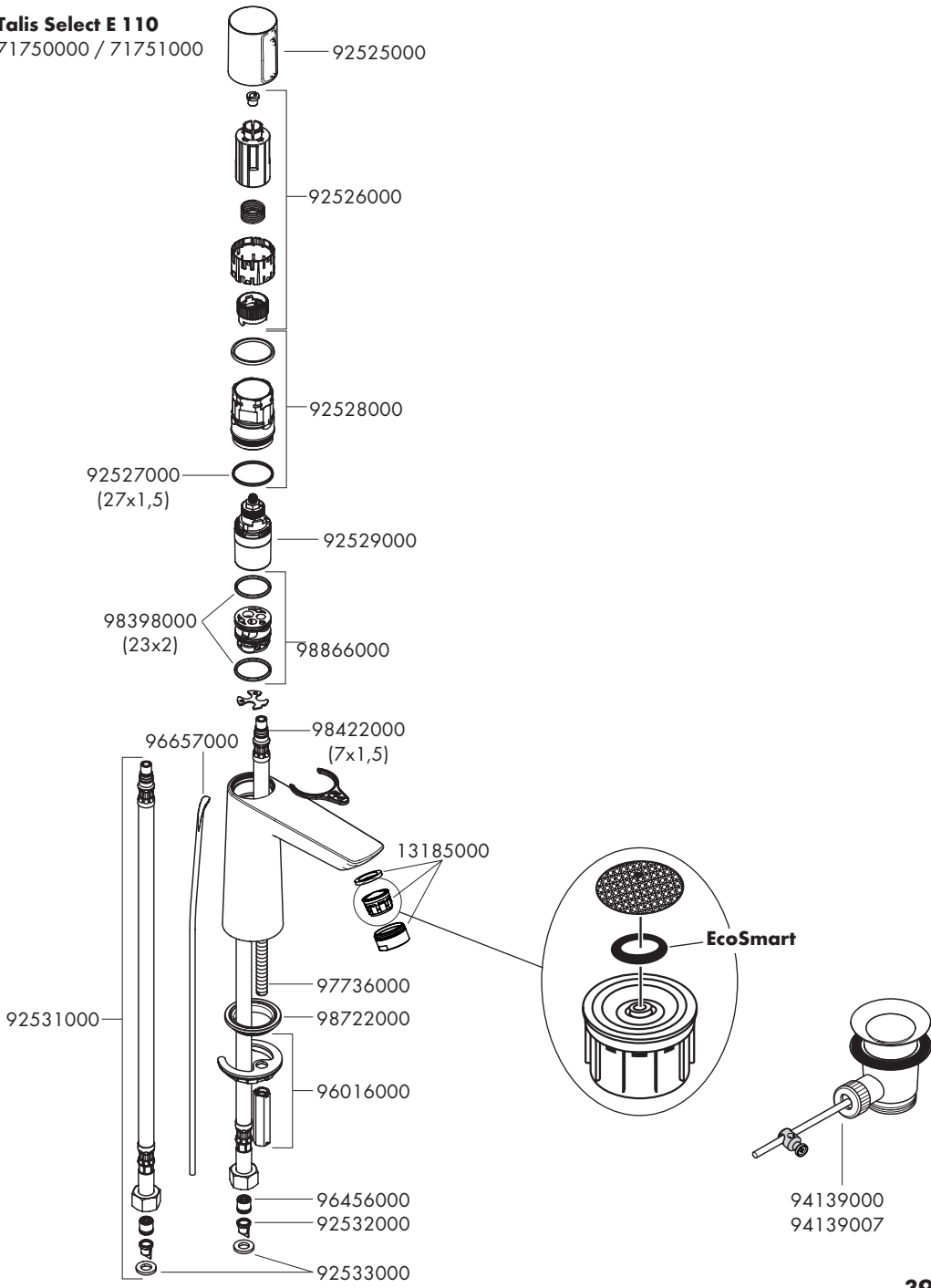

---

**hansgrohe**

Hansgrohe · Austraße 5 · 9 · D-77761 Schiltach · Telefon +49 (0) 78 36/51-1282 · Telefax +49 (0) 7836/511440  
E-Mail: [info@hansgrohe.com](mailto:info@hansgrohe.com) · Internet: [www.hansgrohe.com](http://www.hansgrohe.com)

03/2015  
9.02938.01