

- F Notice de montage ● GB Installation instructions
- E Manual de instalación ● I Istruzioni di montaggio
- NL Montage instructies ● D Montageanleitung

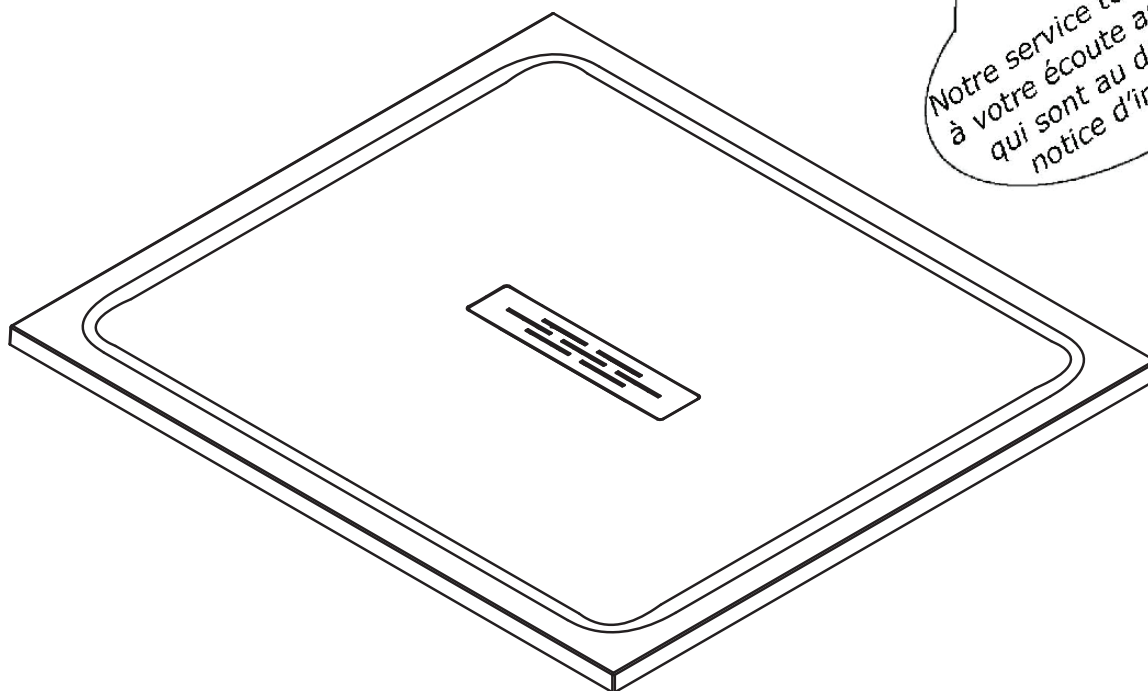

Notre service technique est à votre écoute aux numéros qui sont au dos de cette notice d'installation



- F Attention aux étapes :
- GB Check installation steps :
- E Atención a los pasos :
- I Attenzione ai passi :
- NL Aandacht voor de stappen :
- D Achtung vor den Schritten :

P. 7 - 32 - 34

(A)

X1

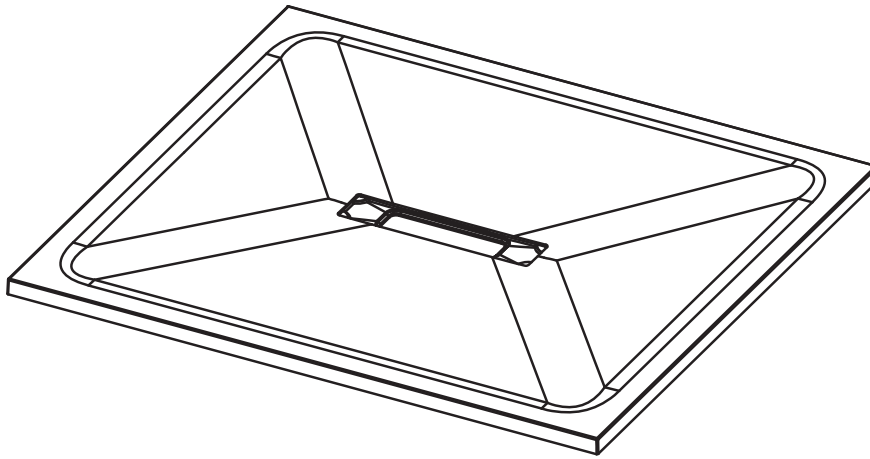

REC664	70X70	REC669	100X70	REC674	110X80	REC679	130X70	REC684	140X100	REC689	160X70	REC694	170X80	REC699	190X90
REC665	75X75	REC670	100X80	REC675	120X70	REC680	130X80	REC685	150X70	REC690	160X80	REC695	170X90	REC700	200X100
REC666	80X80	REC671	100X90	REC676	120X80	REC681	140X70	REC686	150X80	REC691	160X90	REC696	180X80		
REC667	90X70	REC672	100X100	REC677	120X90	REC682	140X80	REC687	150X90	REC692	160X100	REC697	180X90		
REC668	90X90	REC673	110X70	REC678	120X100	REC683	140X90	REC688	150X100	REC693	170X70	REC698	180X100		

(B)

X1

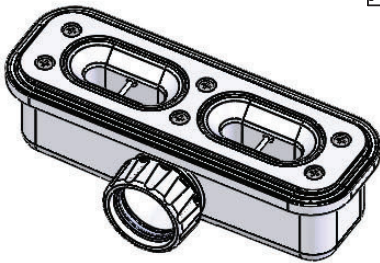

BOND38

(C)

X1

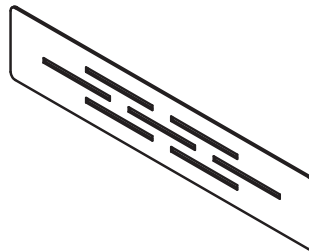

TOL161

- ① Les quantités données sont les quantités utiles au montage. les sachets fournis contiennent des pièces supplémentaires.
- ② The quantities given are what are required for the installation. There may be some surplus in the package provide.
- ③ Las cantidades indicadas son las cantidades necesarias para el montaje. Las bolsitas incluidas contienen piezas suplementarias.
- ④ Le quantità fornite sono le quantità necessarie al montaggio. I sacchetti forniti contengono pezzi supplementari.
- ⑤ De aangegeven aantallen zijn bestemd voor de montage. De bijgeleverde zakjes bevatten extra onderdelen
- ⑥ Die Mengenangaben beziehen sich auf die für die Montage benötigten Teile. Es kann eine gewisse Überzahl an Teilen in der Packung vorhanden sein.

(F) Matériel nécessaire (GB) Tools required (E) Material necesario
 (I) Materiale necessario (NL) Benodigdheden (D) Erforderliche Werkzeuge

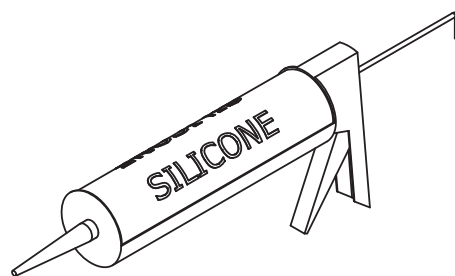
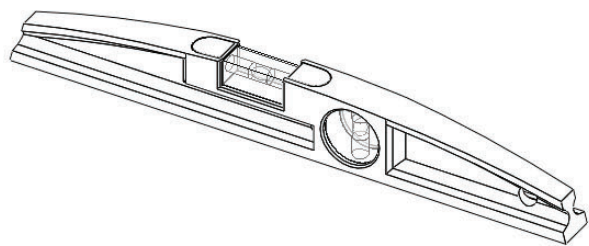

- (F) Colle polyuréthane ou MS polymère
- (GB) Polyurethane adhesive or MS polymer
- (E) Pegamento poliuretano o polímero MS
- (I) Colla poliuretana o MS polimero
- (NL) Polyurethaan of MS-polymeer lijm
- (D) Polyurethan oder MS-Polymere Montagekleber verwenden

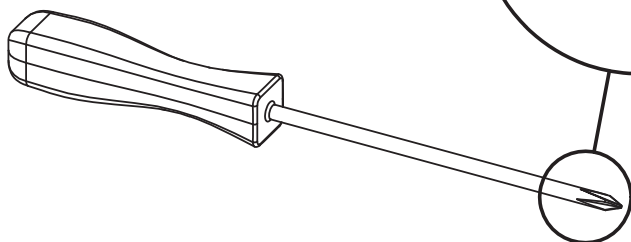
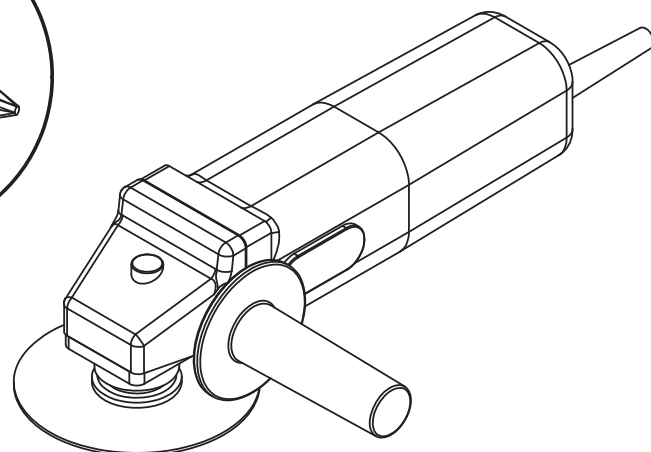
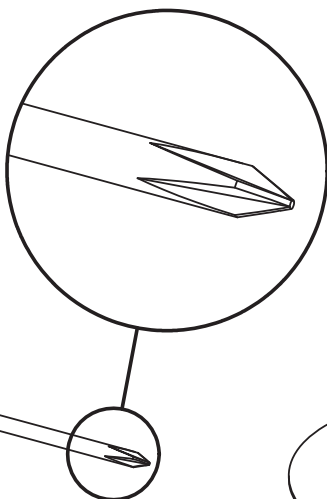
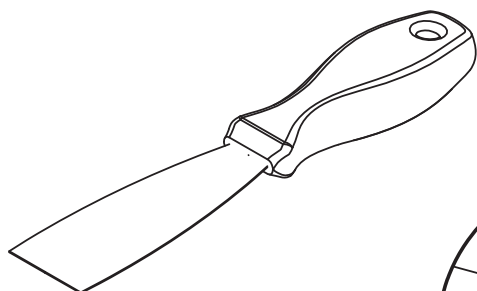

- (F) Meuleuse avec lame diamant Ø230mm min.
- (GB) Grinder with diamond blade Ø230mm min.
- (E) Pulidora con disco diamantado Ø230mm min.
- (I) Mola con lama diamantata Ø230mm min.
- (NL) Diamantslijpschijf Ø230mm min.
- (D) Winkelschleifer mit Diamanttrennscheibe Ø230mm min.



- F DECOUPE OPTIONNELLE DU RECEVEUR
- GB ZONE AVAILABLE FOR OPTIONAL RECUTTING
- E RECORTE OPCIONAL
- I TAGLIO OPZIONALE DEL PIATTO
- NL ZAGEN VAN DE DOUCHEBAK, OPTINEEL
- D OPTIONALE SCHNEIDBEREICHE DER DUSCHWANNE

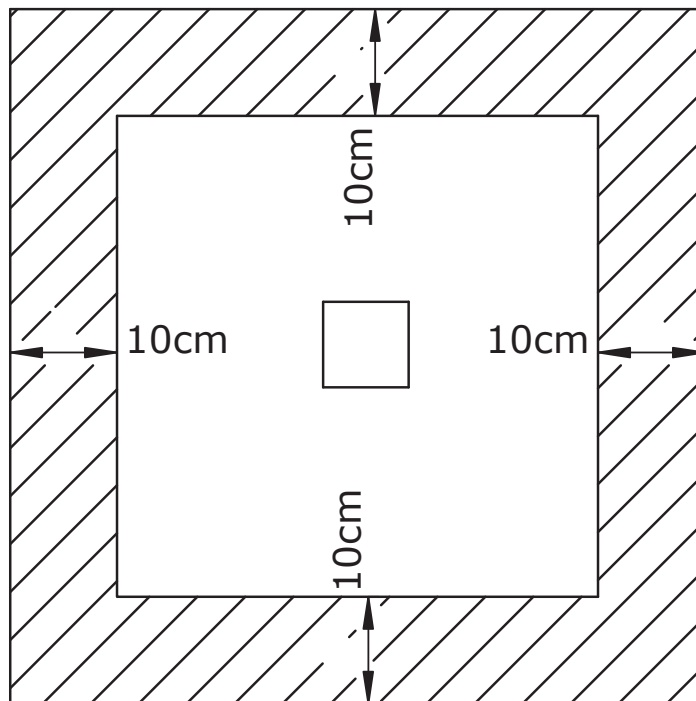
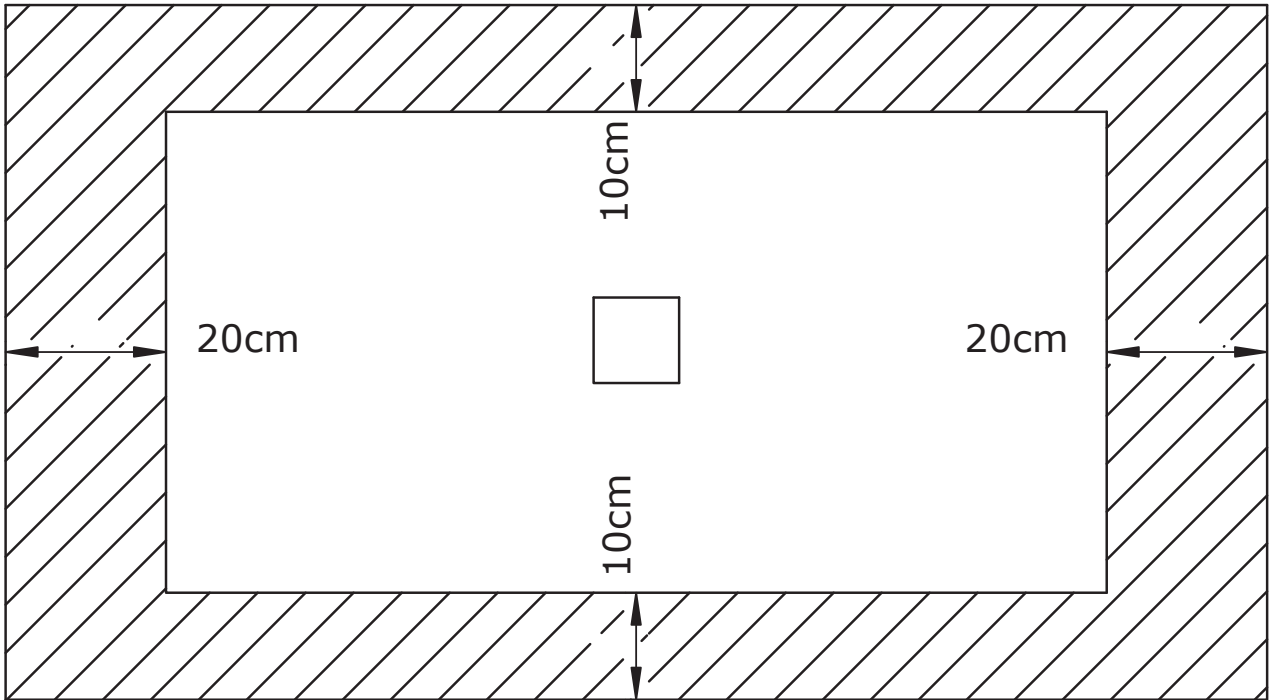

- F Zone MAXI découpable
- D MAX cuttable area
- E Zone MAXIMA de recorte
- I Limite MASSIMO di taglio
- NL MAXIMAAL aanpasbaar deel
- D MAXIMALER Schneidbereich

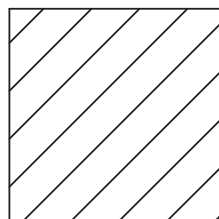

1

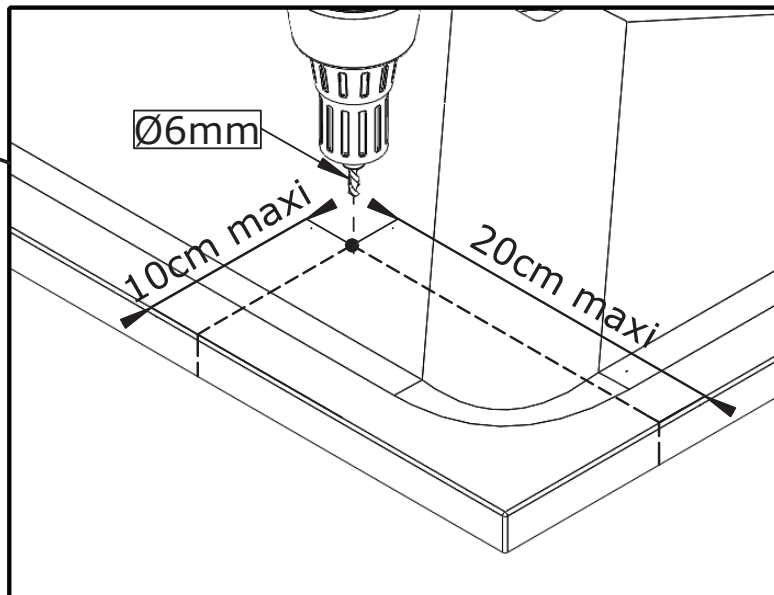
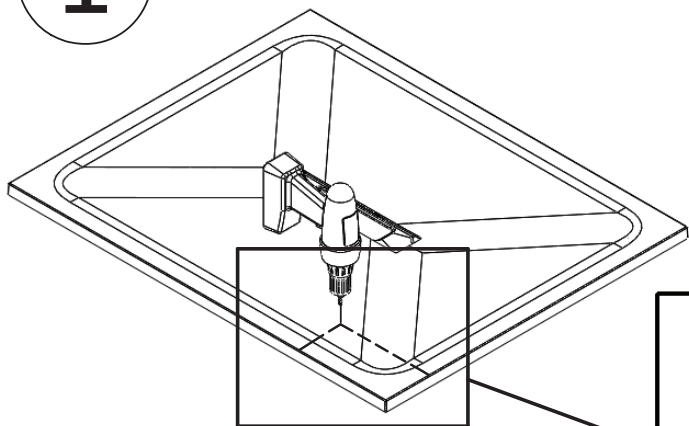

2

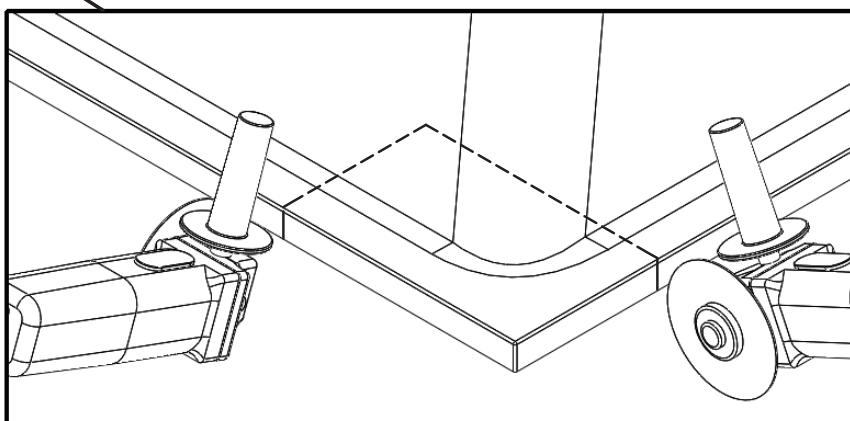
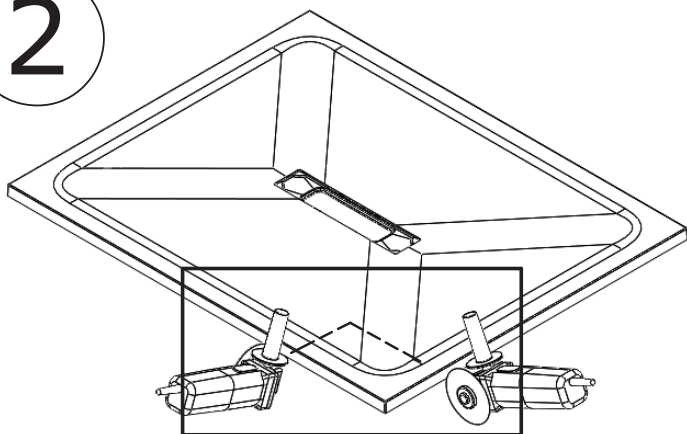

3



F-Appliquer une couche de colle polyuréthane ou MS polymère à l'aide d'une spatule sur la surface coupée et combler l'espace entre les nervures du receveur avec une couche de mortier adhésif.

GB-Apply a polyurethan adhesive or MS polymer layer using a spatula over the raw surface and fill the space between the ribs of the tray with a layer of adhesive mortar.

E-Aplicar una capa de pegamento poliuretano o polímero MS en la superficie recortada. Puede ayudarse de una espátula y rellenar los espacios huecos del plato con una capa de mortero adhesivo.

I-Applicare della colla poliuretanică o MS polimero con l'aiuto di una spatola sulla parte tagliato e compensare lo spazio tra le venature del piatto con uno strato di materiale adesivo.

NL-Breng met een spatel een laag polyurethaan lijm of MS polymeer lijm aan op de zaagranden, en vul de tussenliggende ruimte tot het steunoppervlak van de douchebak op met een laag cement.

D-Wenn Sie ihre Duschtasse zuschneiden, müssen die Schnittkanten mittels Polyurethan- oder MS-Polymer-Klebstoff versiegelt werden. Tragen Sie die Versiegelung mit einem Spachtel auf der Schnittfläche bis unterhalb der Duschtasse auf.

- F** Colle polyuréthane/MS polymère
- GB** Polyurethane adhesive/MS polymer
- E** Pegamento poliuretano/polimero MS
- I** Colla poliuretanică/MS polimero
- NL** Polyurethaan/MS polymeer lijm
- D** Schicht aus Polyurethan-/MS-Polymer-Klebstoff

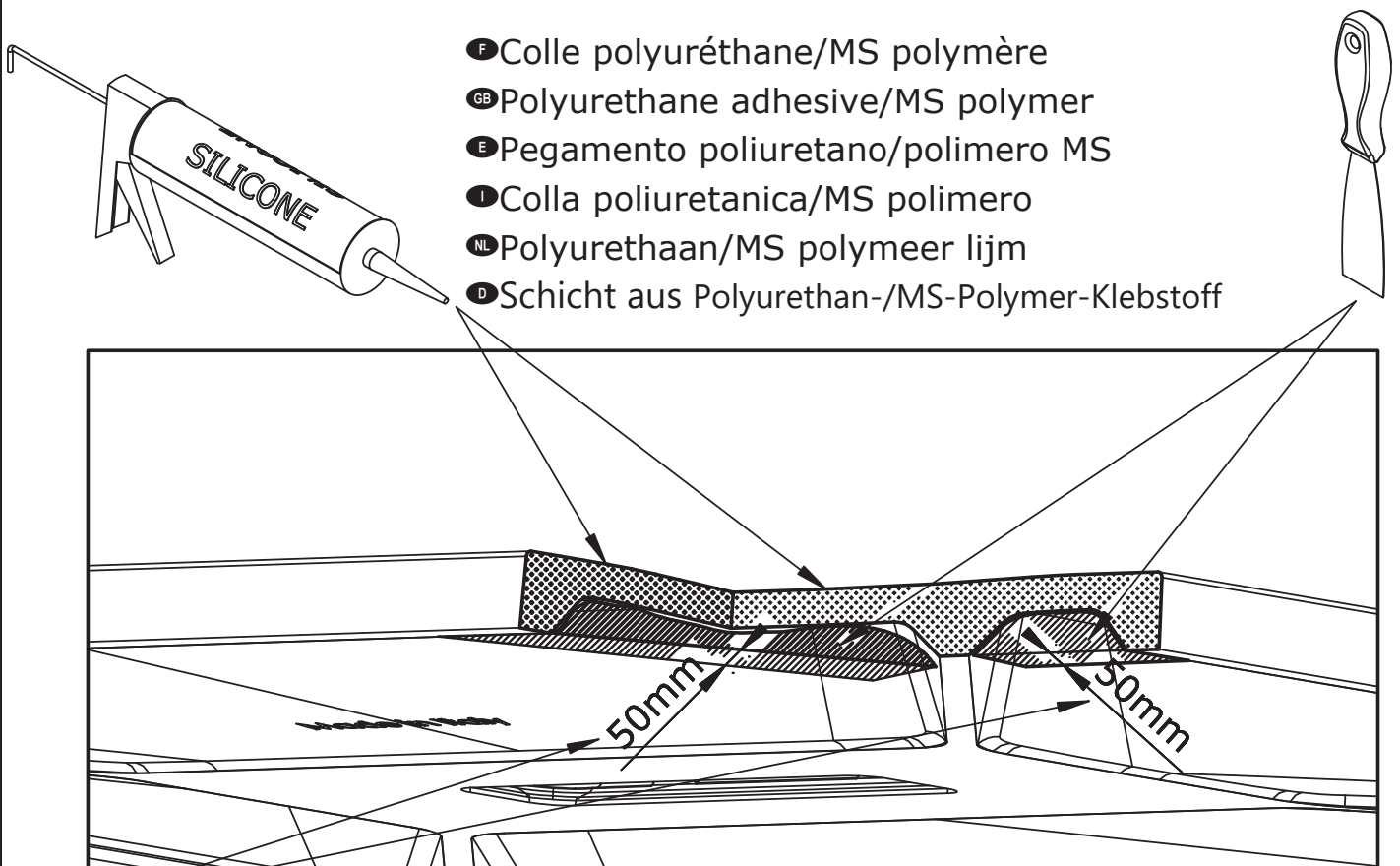

- F** Couche de 50mm de mortier adhésif
- GB** 50mm layer of adhesive mortar
- E** Capa de 50mm de grosor de mortero adhesivo
- I** Strato di 50mm di materiale adesivo
- NL** Laag van 50mm lijm mortel
- D** 50 mm Versiegelung auftragen

ⓕ Nombre de pieds Ⓜ Feet quantity ⓔ Cantidad de pies

Ⓜ Quantità di piedini Ⓝ Hoeveelheid voeten Ⓝ Anzahl an FüÙe

REC664	70X70	4	REC673	110X70	8	REC682	140X80	10	REC691	160X90	10	REC700	200X100	14
REC665	75X75	4	REC674	110X80	8	REC683	140X90	10	REC692	160X100	12			
REC666	80X80	4	REC675	120X70	8	REC684	140X100	10	REC693	170X70	10			
REC667	90X70	4	REC676	120X80	8	REC685	150X70	10	REC694	170X80	10			
REC668	90X90	4	REC677	120X90	8	REC686	150X80	10	REC695	170X90	10			
REC669	100X70	4	REC678	120X100	8	REC687	150X90	10	REC696	180X80	12			
REC670	100X80	4	REC679	130X70	8	REC688	150X100	12	REC697	180X90	12			
REC671	100X90	4	REC680	130X80	8	REC689	160X70	10	REC698	180X100	14			
REC672	100X100	8	REC681	140X70	10	REC690	160X80	10	REC699	190X90	12			

ⓕ La distance bord à bord entre deux pieds ne doit pas être de plus de 30 cm.
LES PIEDS DOIVENT ETRE INSTALLES SUR LES NERVURES DU RECEVEUR.

Ⓜ The distance from the edge of the shower tray to the edge of a peripheral support should be no more than 30 cm.
THE FEET MUST BE INSTALLED ON THE SHOWER TRAY RIBS.

ⓔ La distancia entre cada pie no debe superar los 30 cm.
LOS PIES DEBEN ESTAR INSTALADOS SIGUIENDO LAS NERVIOS DEL PLATO.

Ⓜ La distanza tra due piedi non dovrebbe essere superiore a 30 cm.
I PIEDI DEVONO ESSERE ISTALLATI SULLE NERVATURE DEL PIATTO DOCCIA.

Ⓝ De afstand tussen twee stelpoten mag niet meer dan 30 cm bedragen.
DE STELPOTEN DIENEN OP HET STEUNOPPERVLAK VAN DE DOUCHEBAK GEÏNSTALLEERD TE WORDEN.

Ⓝ Der Abstand zwischen zwei verstellbaren FüÙen darf 30 cm nicht überschreiten.
DIE FÜÙE MÜSSEN AUF DEN TRÄGERN DER DUSCHTASSE MONTIERT WERDEN.

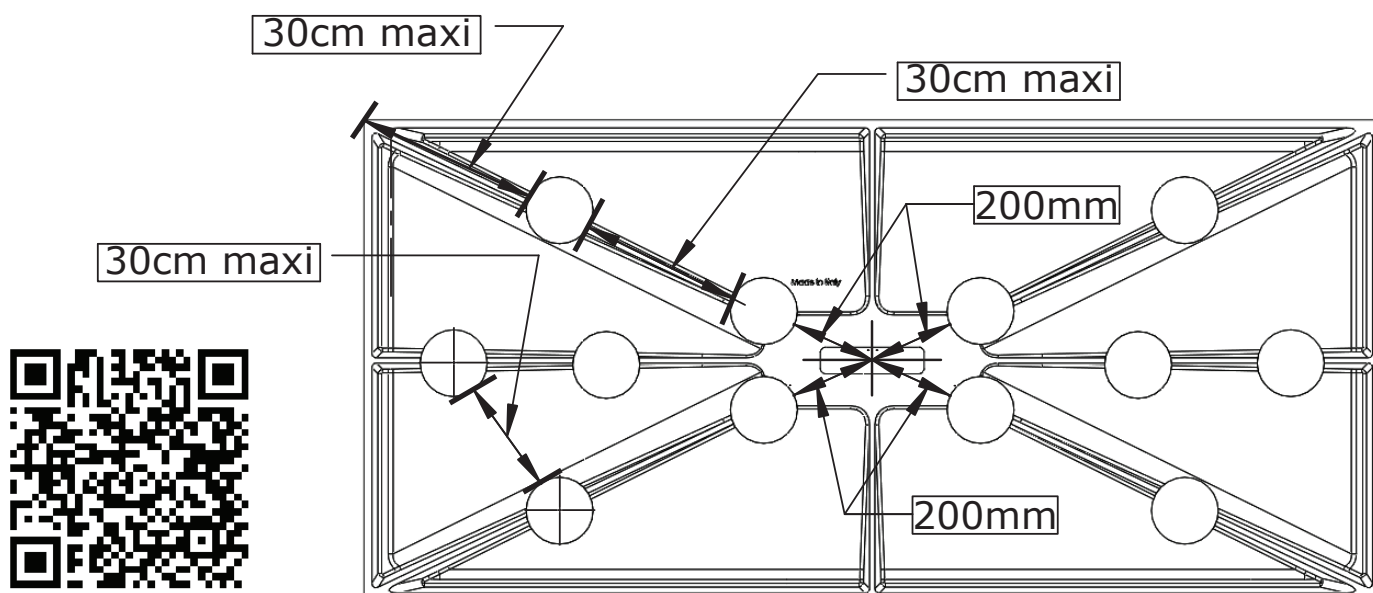

F

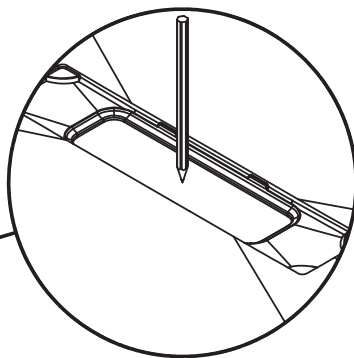
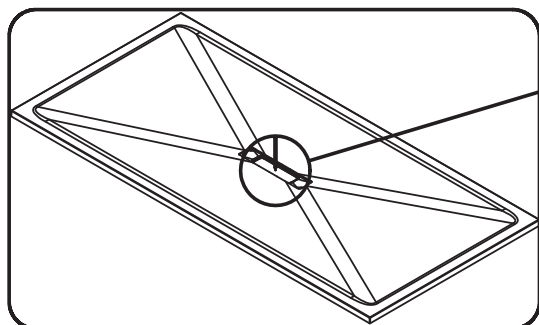

Tracer la position de la bonde et réaliser un montage à blanc de la bonde et du receveur

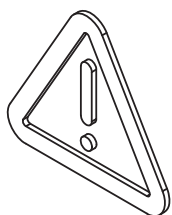
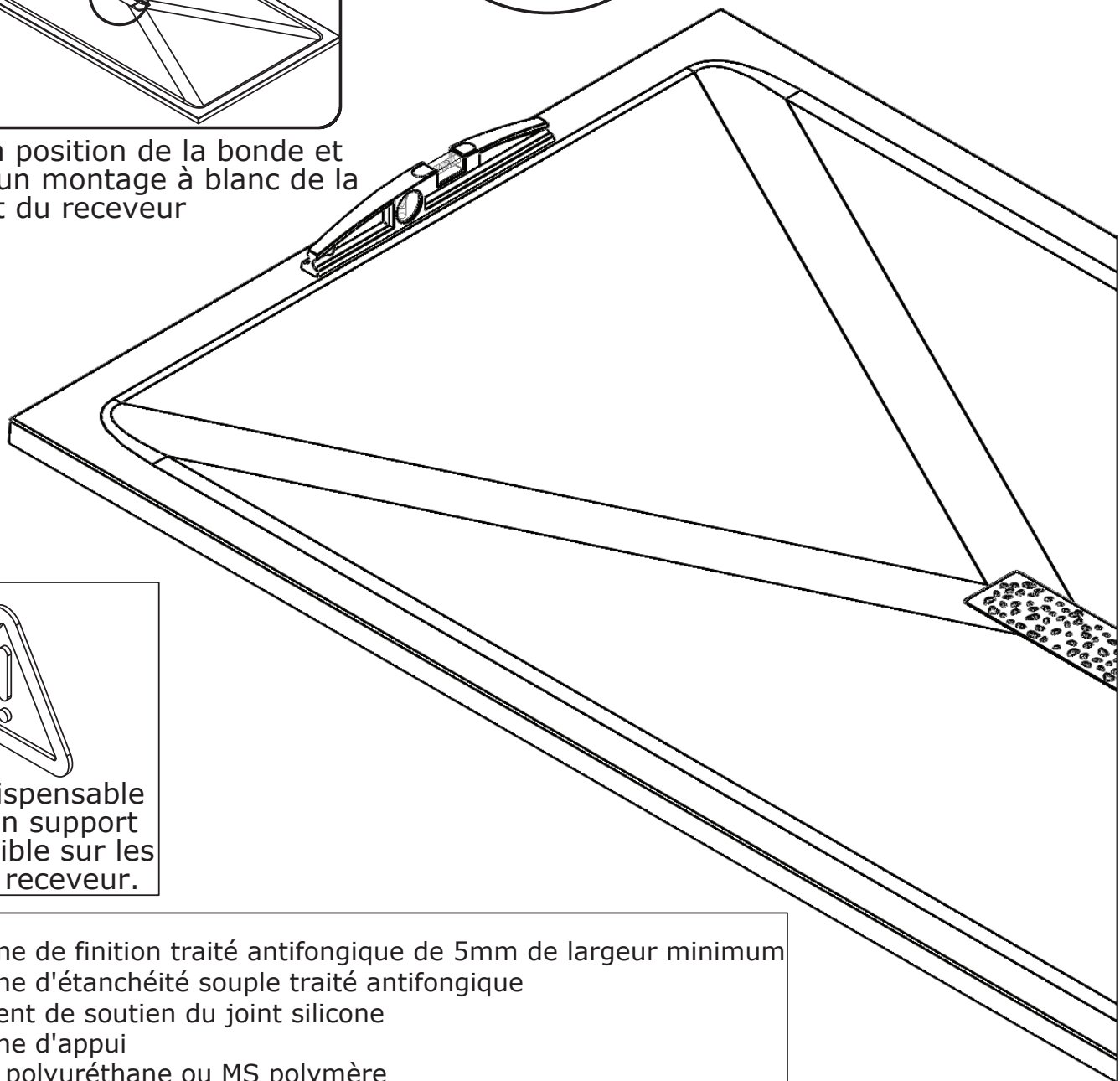

Il est indispensable d'avoir un support imputrescible sur les côtés du receveur.

- ① - silicone de finition traité antifongique de 5mm de largeur minimum
- ② - silicone d'étanchéité souple traité antifongique
- ③ - élément de soutien du joint silicone
- ④ - silicone d'appui
- ⑤ - colle polyuréthane ou MS polymère

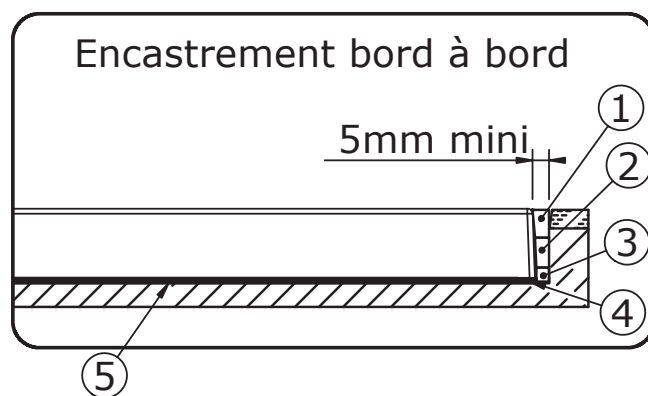
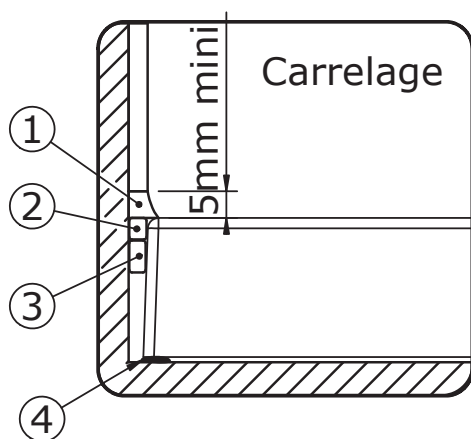



Pendant toute la durée des travaux, protéger le receveur contre toute agression : brûlures, chocs, rayures, décapants...



Le montage d'une soupape anti-vide est nécessaire pour une utilisation optimale si un autre appareil sanitaire est raccordé sur la même évacuation.

Ne pas utiliser d'acide chlorhydrique ni de dégraissant puissant

Pose directe au sol

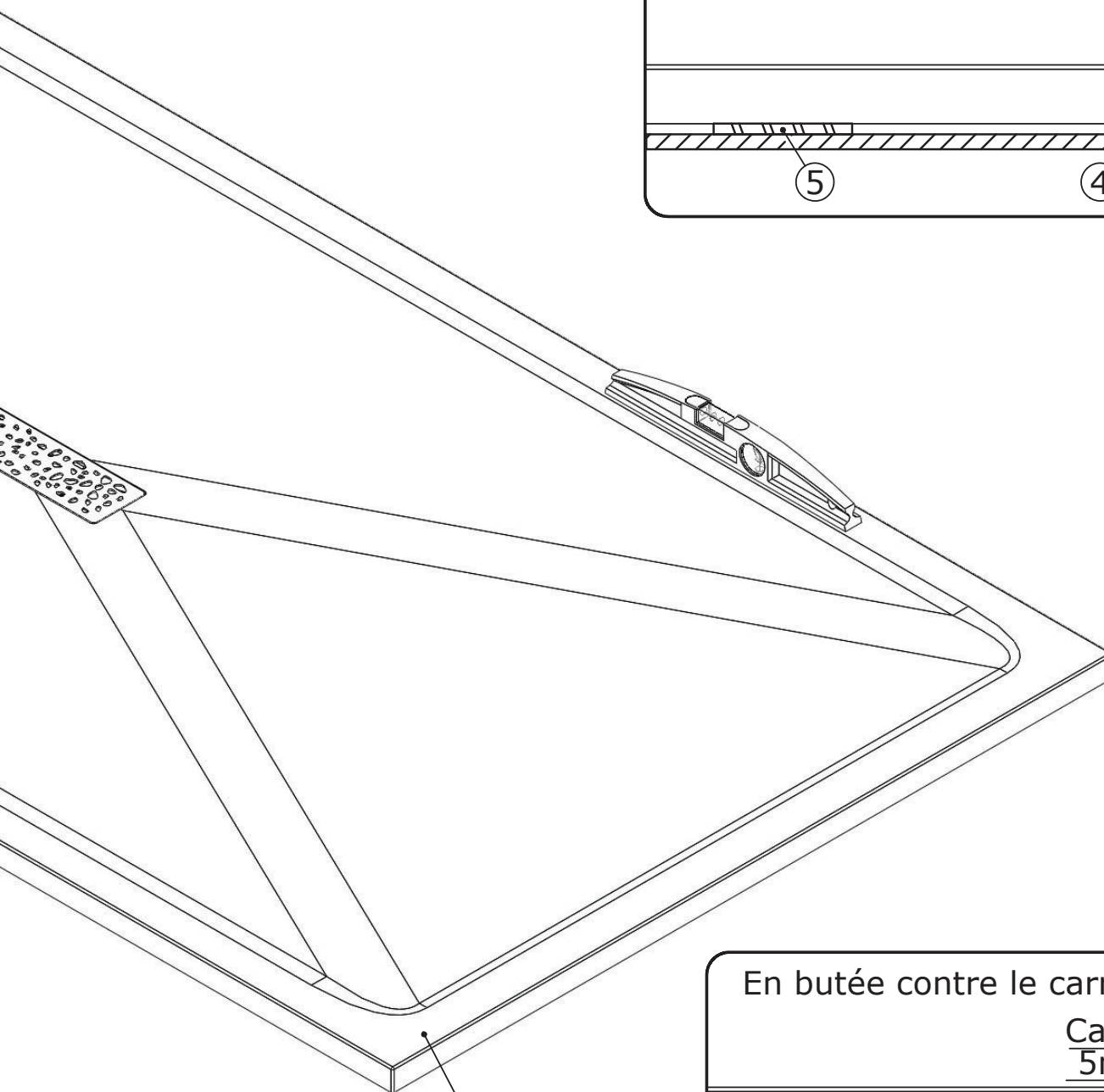
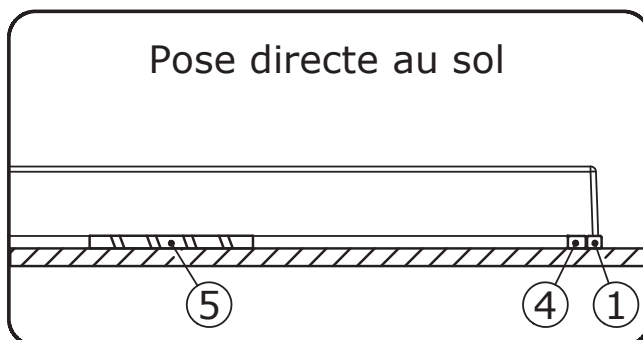

En butée contre le carrelage

Carrelage
5mm

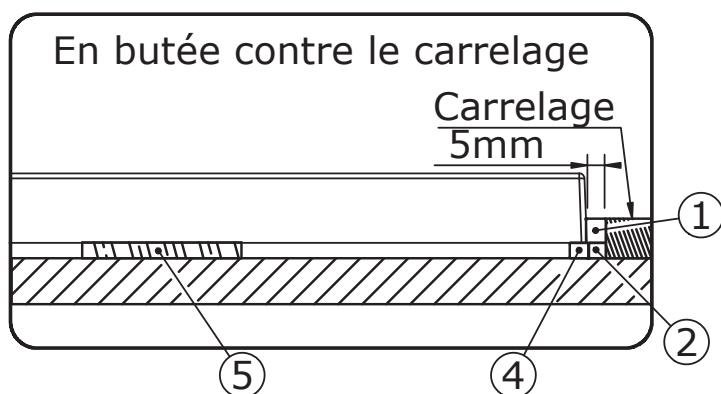

Sol rigide, plan et non humide indispensable

TYPES D'INSTALLATION

KINEMOON STYLE CARRÉ

1. Posé sur pieds réglables avec habillage carrelé

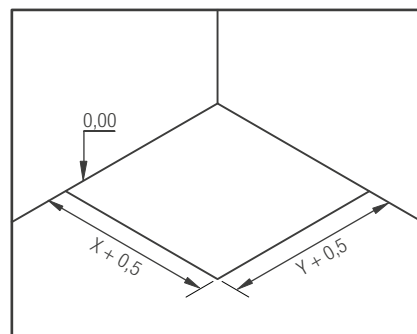
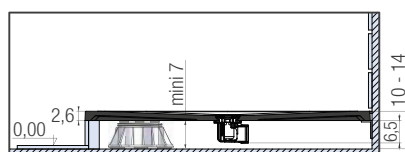
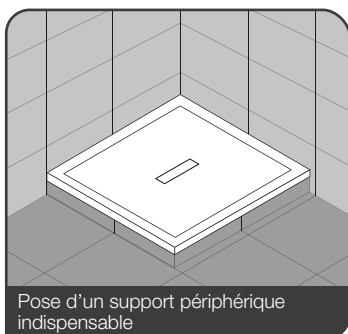

Préparation de l'implantation

2. Posé en butée contre le carrelage

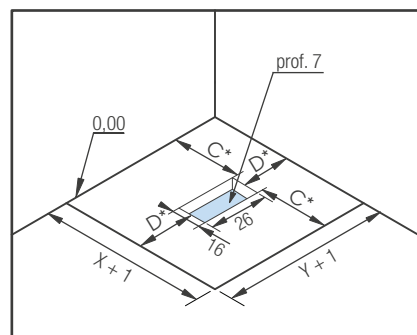
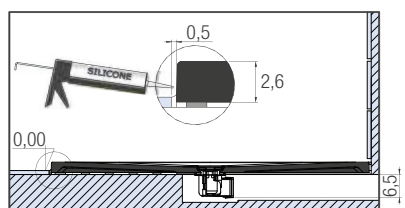
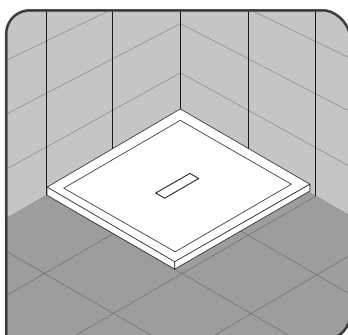

Préparation de l'implantation

3. Encastré et posé sur pieds réglables

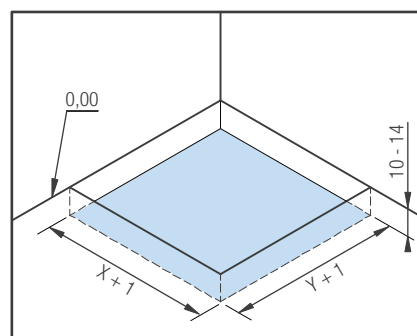
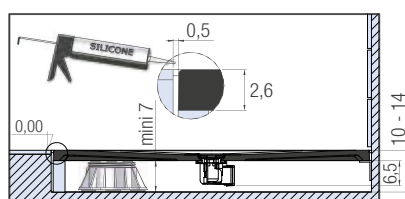

Préparation de l'implantation

4. Encastré et posé sans pieds réglables

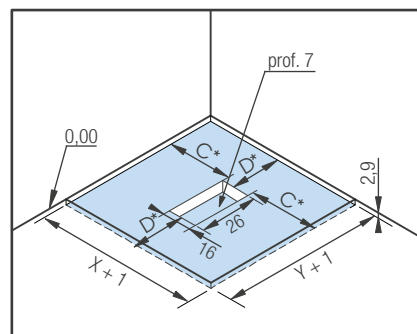
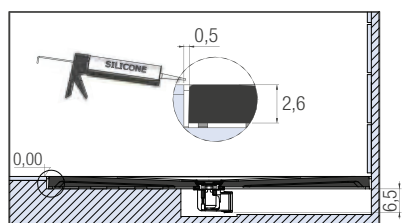
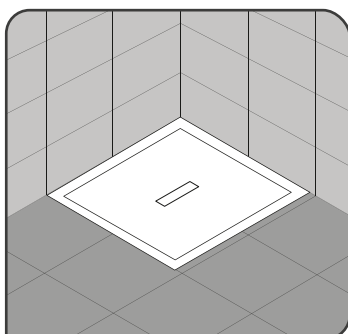

Préparation de l'implantation

TYPES D'INSTALLATION

KINEMOON STYLE RECTANGULAIRE

1. Posé sur pieds réglables avec habillage carrelé

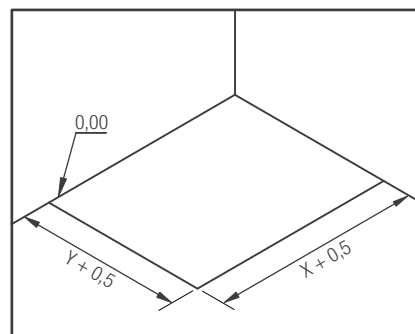
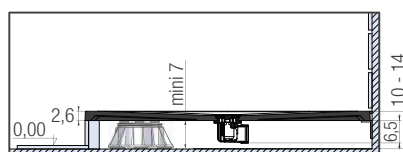

Préparation de l'implantation

2. Posé en butée contre le carrelage

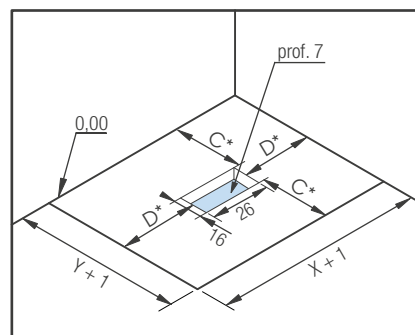
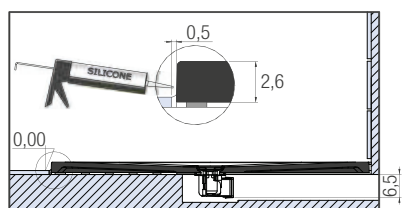
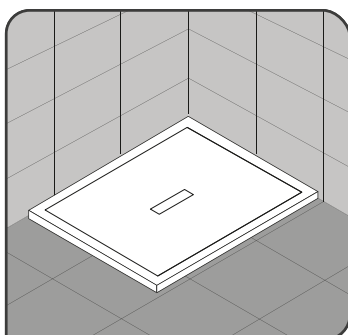

Préparation de l'implantation

3. Encastré et posé sur pieds réglables

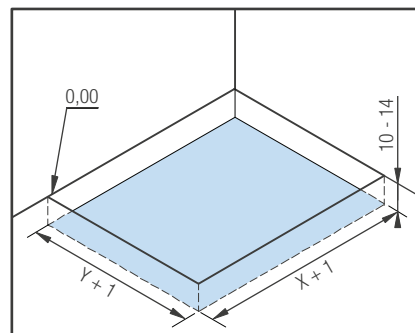
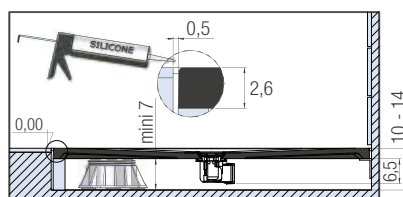

Préparation de l'implantation

4. Encastré et posé sans pieds réglables

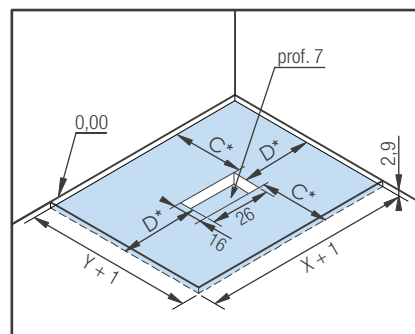
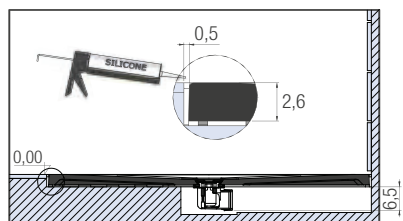
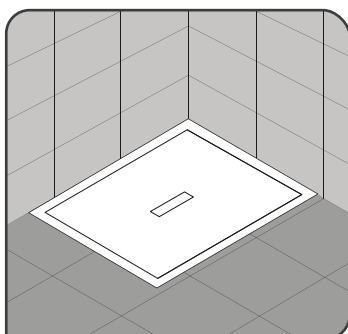

Préparation de l'implantation

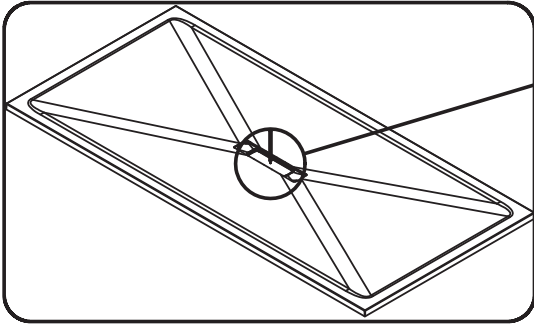

Mark the position of the waste and test-assemble the tray and waste

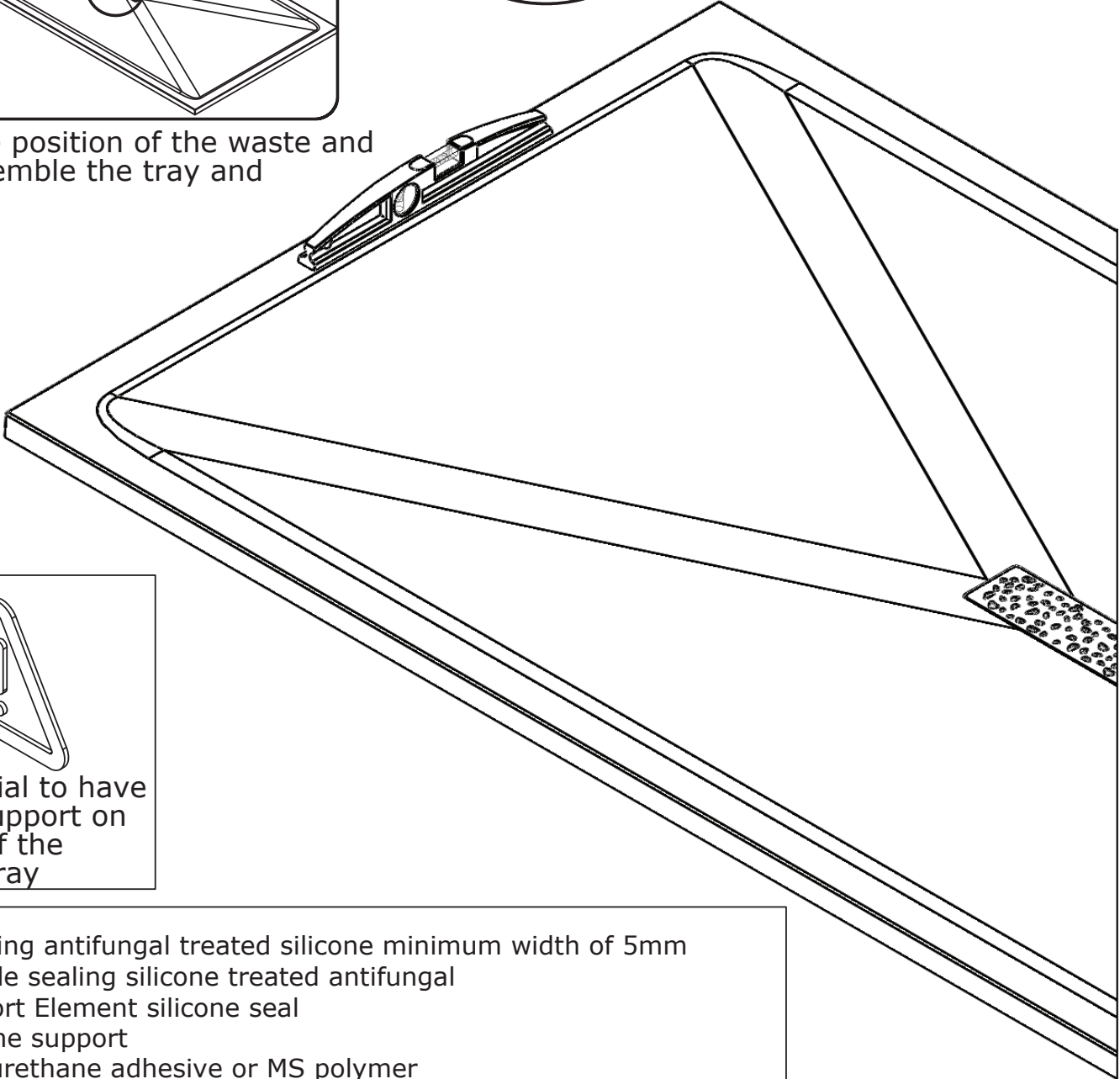

- ① - finishing antifungal treated silicone minimum width of 5mm
- ② - flexible sealing silicone treated antifungal
- ③ - support Element silicone seal
- ④ - silicone support
- ⑤ - polyurethane adhesive or MS polymer

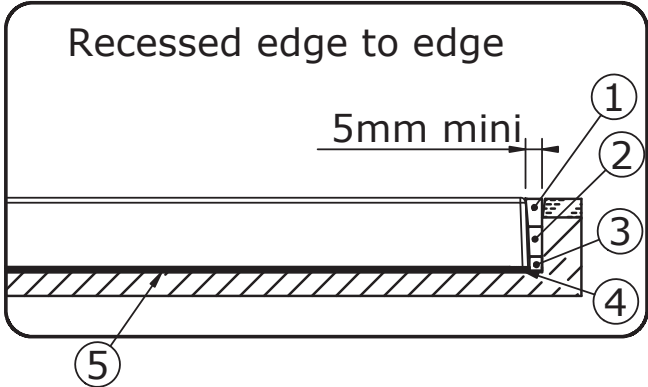
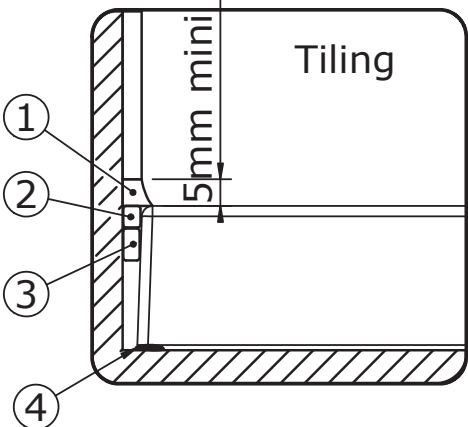



Throughout the protect the tray of the work, protect the recipient against any aggression: burns, shock, scratches, strppers...



Mounting a vacuum relief valve is required for use optimal if another fixture is connected to the same drain.

Do not use hydrochloric acid or powerful degreaser

Direct floor installation

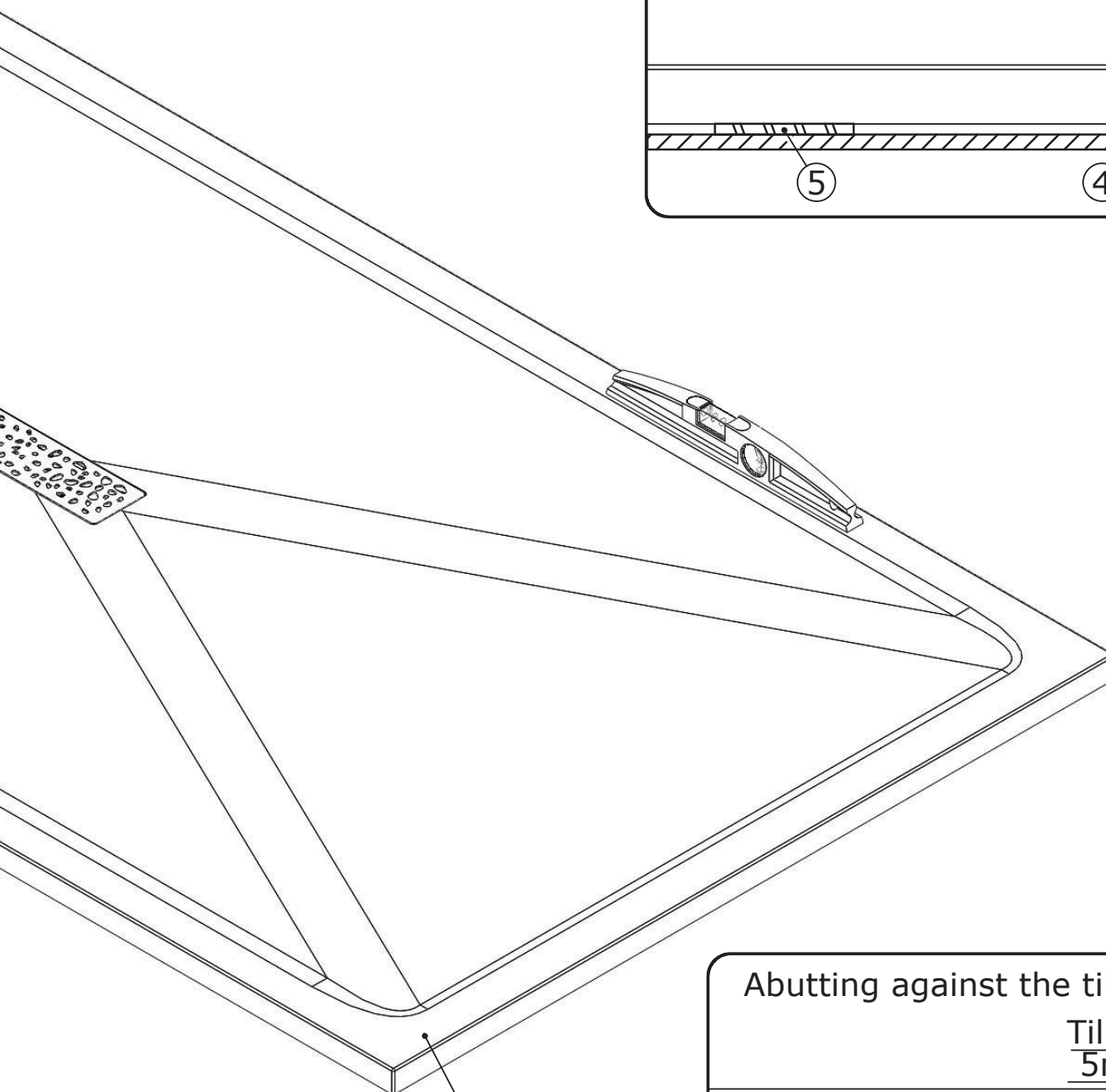
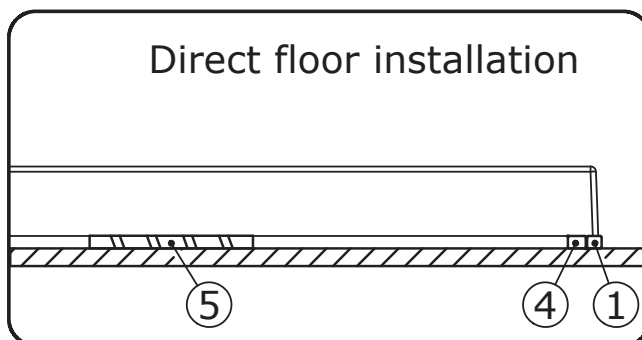

Abutting against the tile

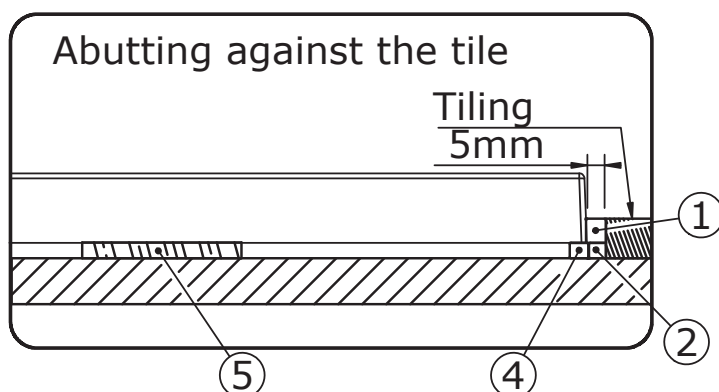

INSTALLATION TYPES

KINEMOON STYLE SQUARE

1. Mounted on adjustable legs with cladding

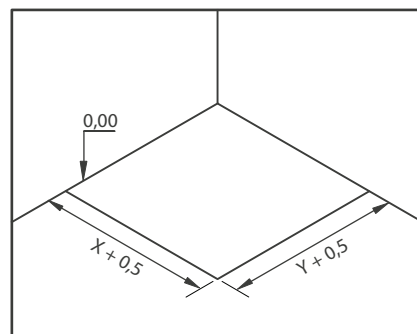
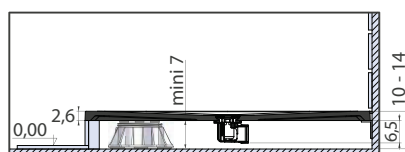
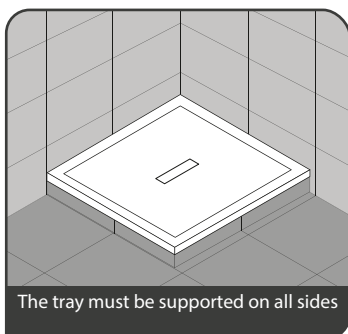

Pre-installation

2. Installed in abutment against the tile

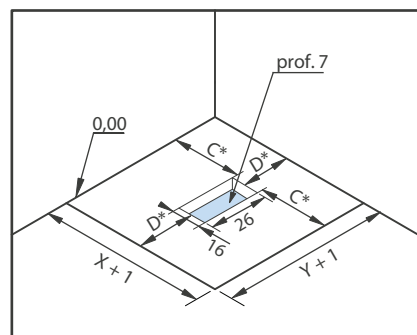
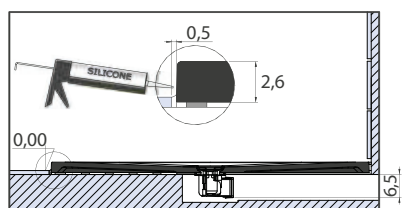
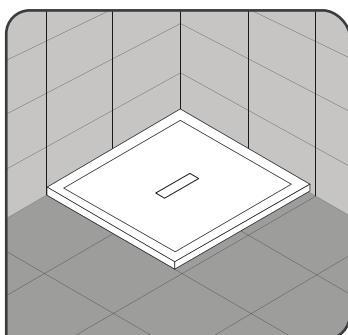

Pre-installation

3. Built-in and placed on adjustable legs

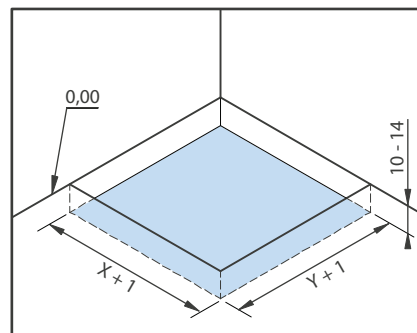
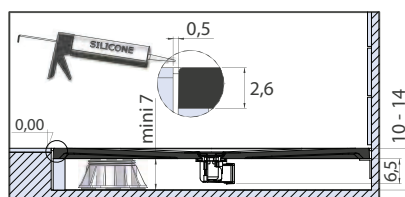
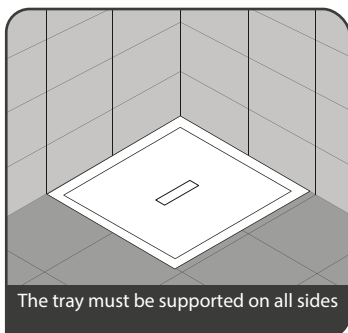

Pre-installation

4. Built-in and installed without adjustable feet

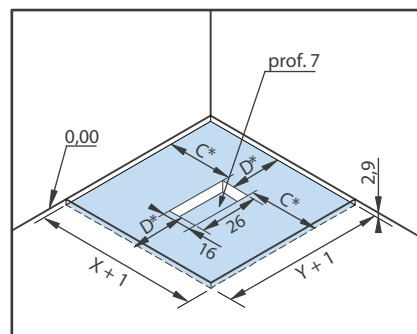
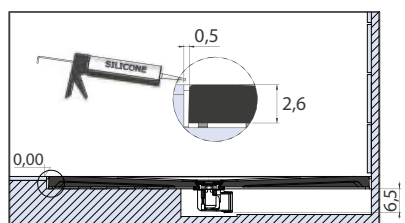
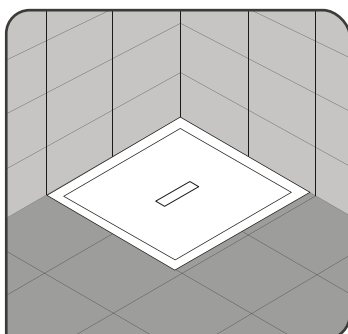

Pre-installation

INSTALLATION TYPES

KINEMOON STYLE RECTANGULAR

1. Mounted on adjustable legs with tiled cladding

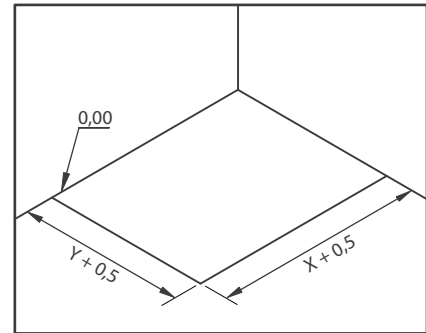
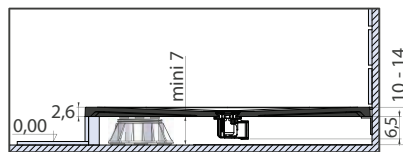

Pre-installation

2. Installed in abutment against the tile

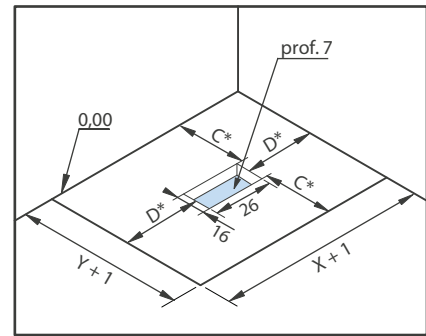
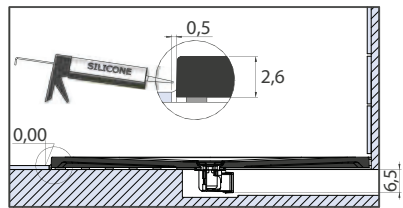
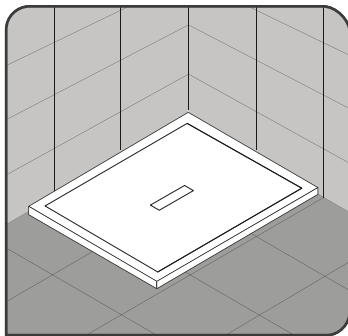

Pre-installation

3. Built-in and installed without adjustable feet

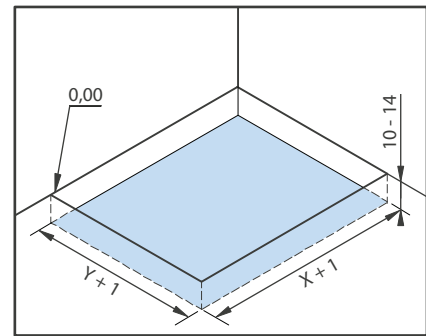
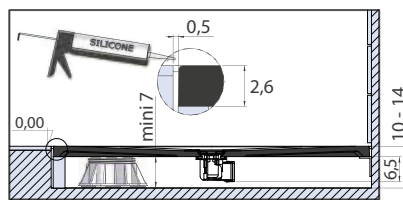
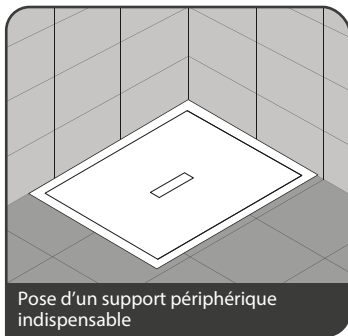

Pre-installation

4. Built-in and installed without adjustable feet

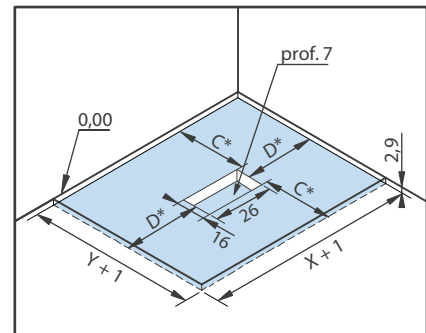
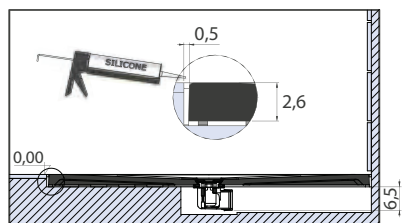
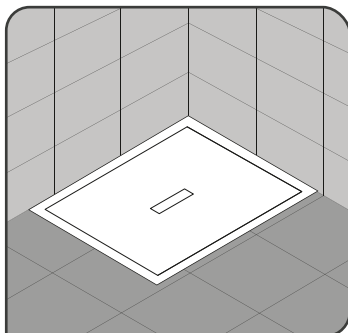

Pre-installation

E

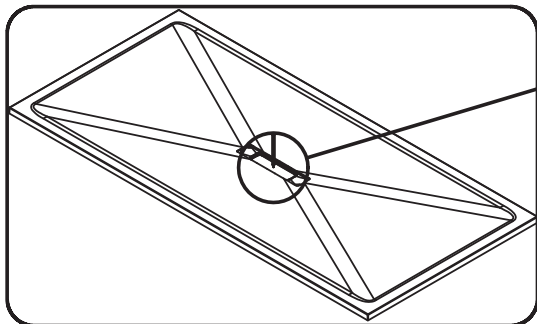

Marcar la ubicación del desagüe y montarlo con el plato para comprobar su correcta ubicación.

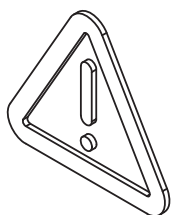
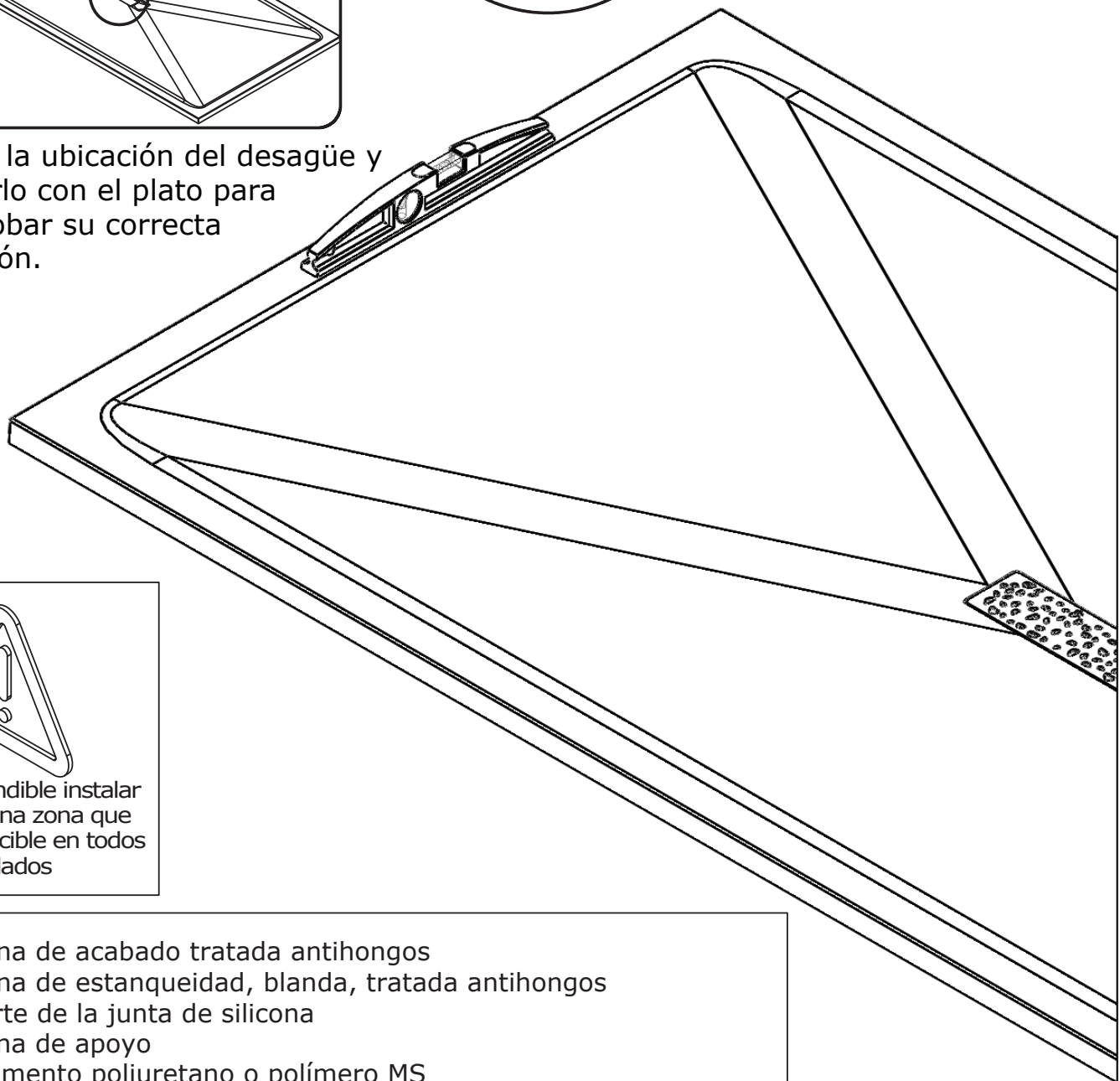

Es imprescindible instalar el plato en una zona que sea imputrescible en todos sus lados

- ① - silicona de acabado tratada antihongos
- ② - silicona de estanqueidad, blanda, tratada antihongos
- ③ - soporte de la junta de silicona
- ④ - silicona de apoyo
- ⑤ - pegamento poliuretano o polímero MS

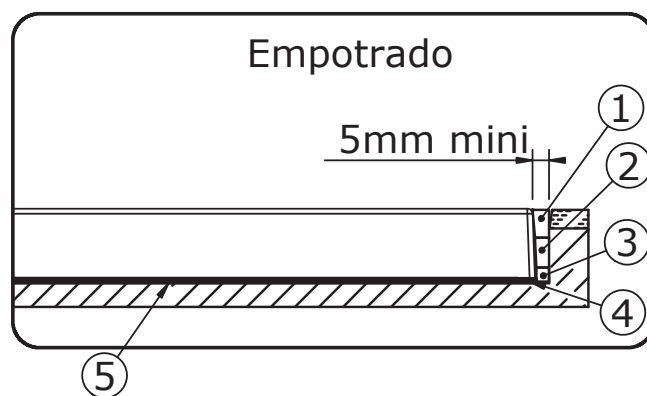
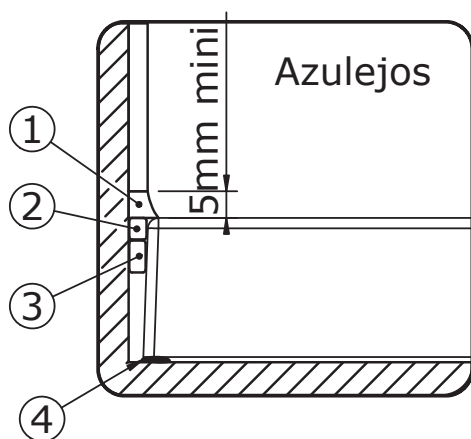



Durante las obras proteger el plato de golpes, quemaduras, rayaduras, etc...



La instalación de un venteo es necesaria si otro aparato está conectado al mismo recorrido de evacuación.

No utilizar ácido clorhídrico o desengrasante potente

Instalación directa al suelo

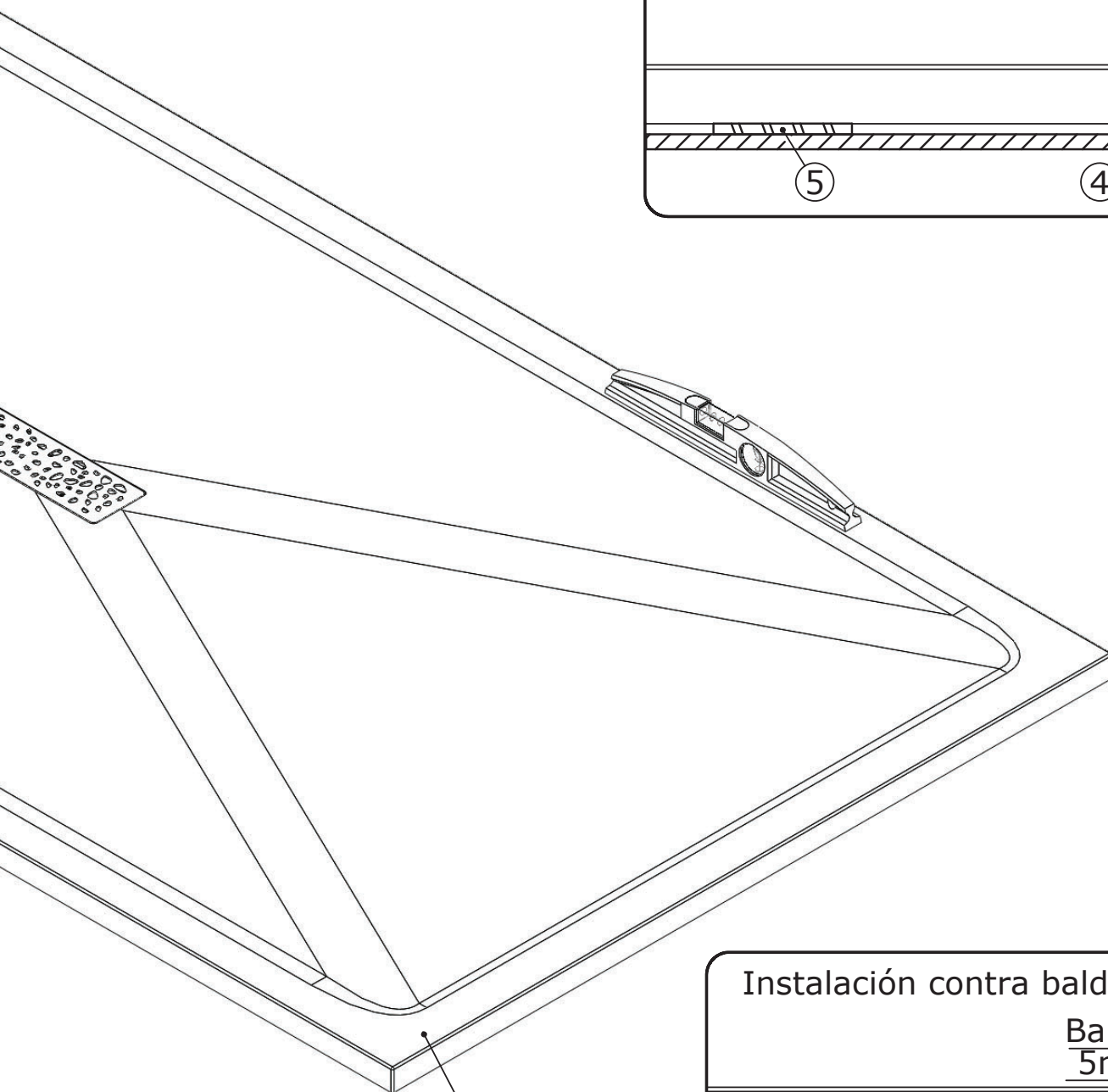
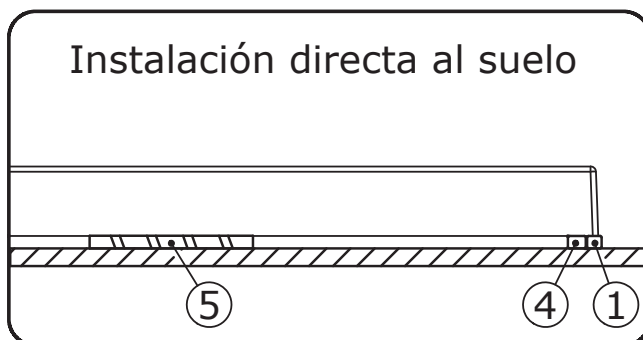

Instalación contra baldosas

Baldosas
5mm

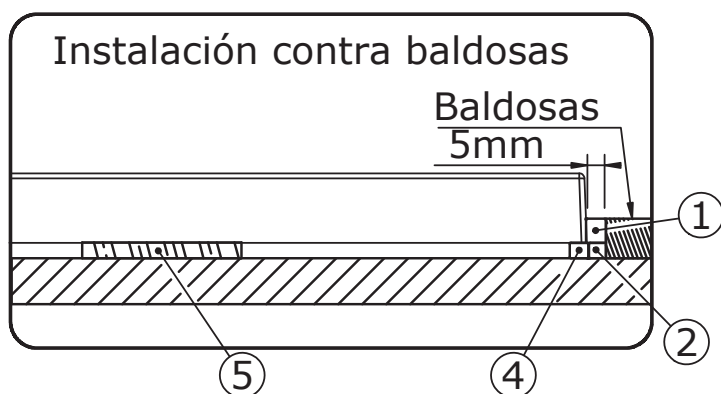

Suelo rígido, plano y seco indispensable

TIPOS DE INSTALACIÓN

KINEMOON STYLE

QUADRADO

1. Instalado sobre pies ajustables con revestimiento de baldosas

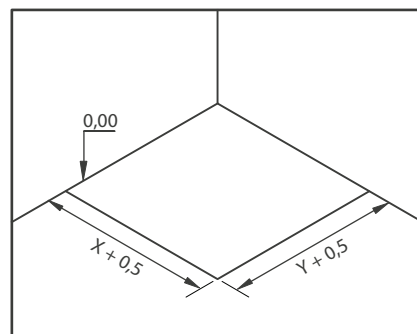
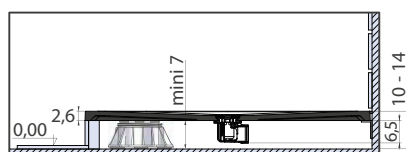

Preparación de la instalación

2. Colocación sobre suelo

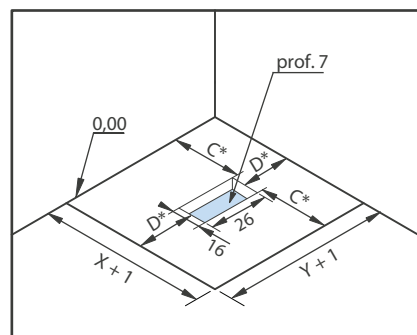
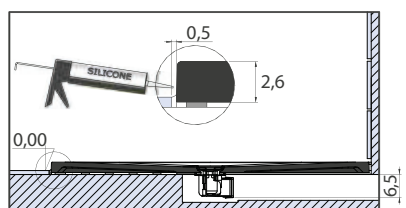
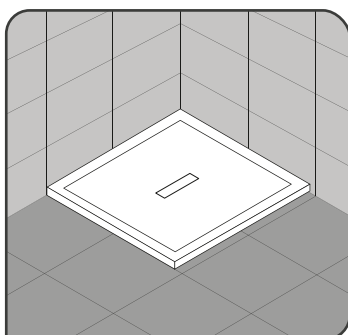

Preparación de la instalación

3. Instalación a ras de suelo, colocado sobre pies ajustables

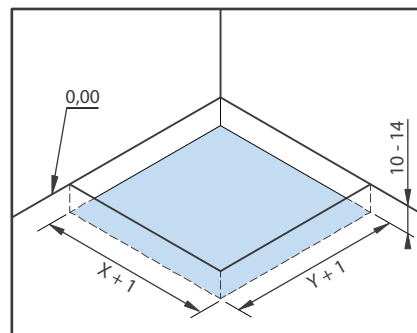
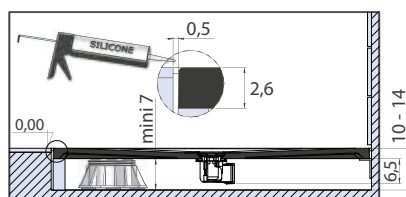

Preparación de la instalación

4. Instalación a ras de suelo, sin pies ajustables

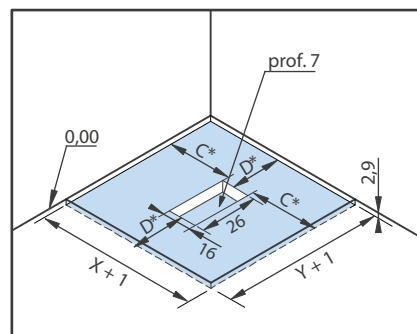
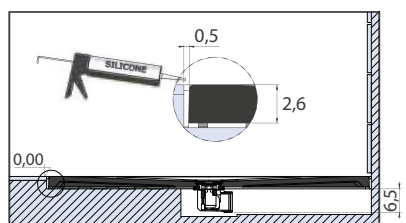
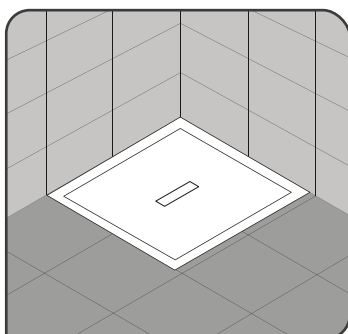

Preparación de la instalación

TIPOS DE INSTALACIÓN

KINEMOON STYLE

RECTANGULARES

1. Instalado sobre pies regulables con revestimiento de baldosas

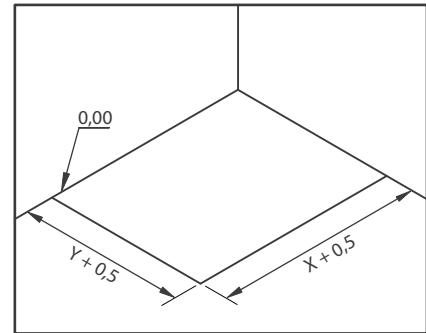
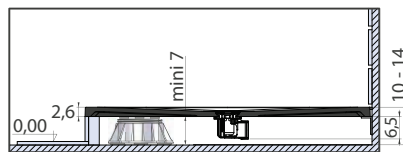

Preparación de la instalación

2. Colocación sobre suelo

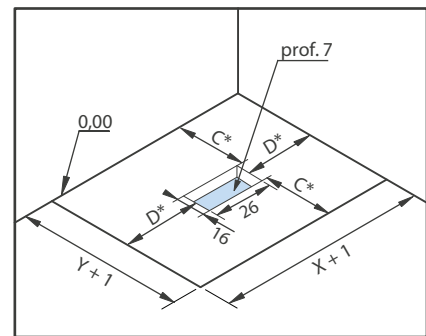
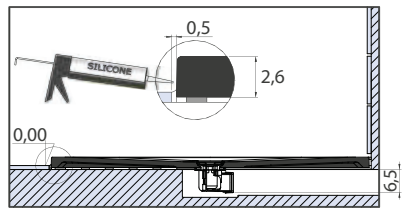
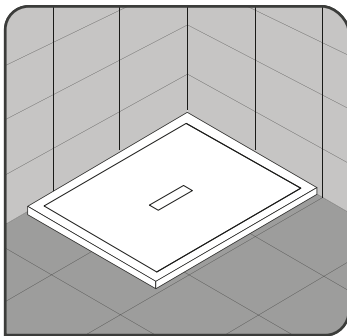

Preparación de la instalación

3. Instalación a ras de suelo, colocado sobre pies regulables

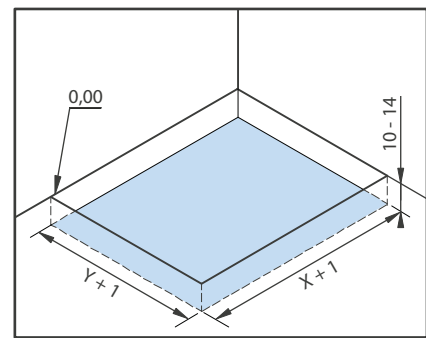
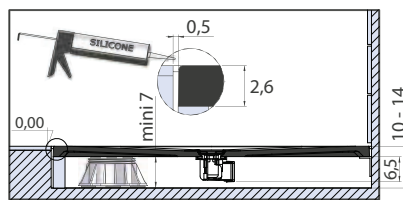

Preparación de la instalación

4. Instalación a ras de suelo, sin pies regulables

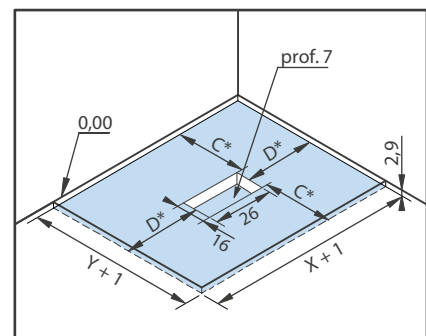
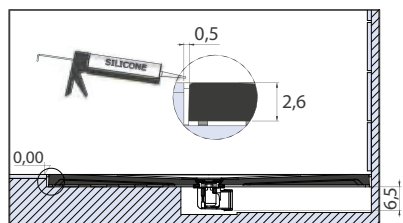
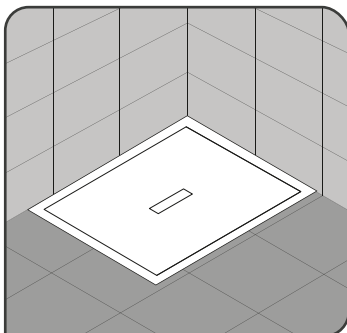

Preparación de la instalación

I

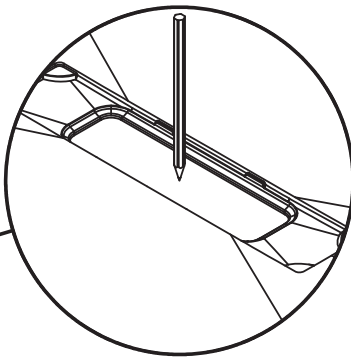
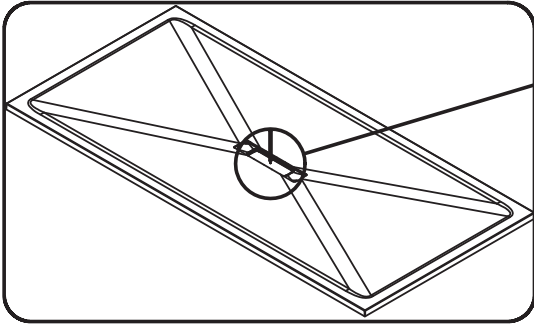

Tracciare la posizione dello scarico e realizzare un montaggio a vuoto dello scarico e del piatto

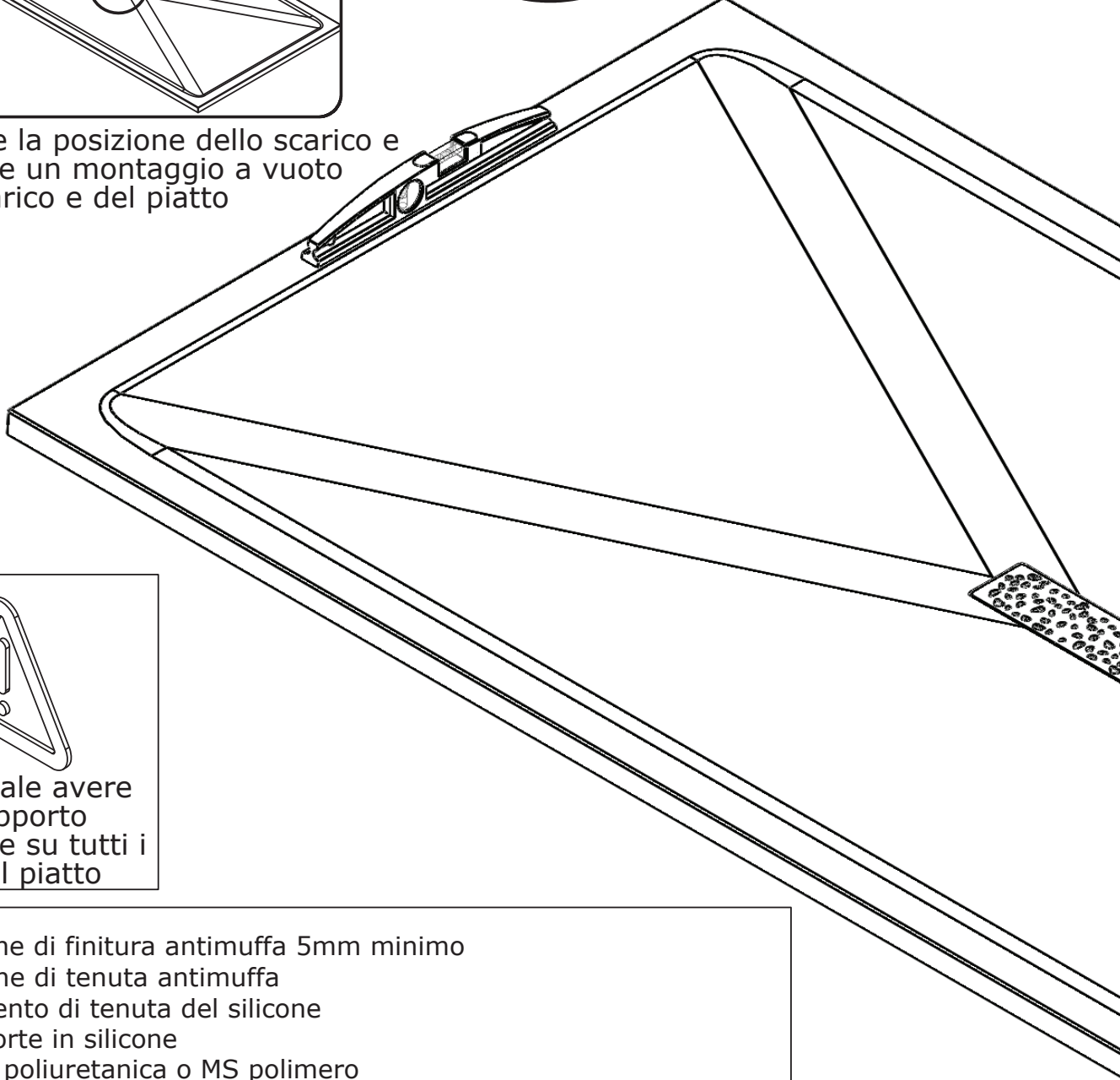

E' essenziale avere un supporto inalterabile su tutti i lati del piatto

- ① - silicone di finitura antimuffa 5mm minimo
- ② - silicone di tenuta antimuffa
- ③ - elemento di tenuta del silicone
- ④ - supporte in silicone
- ⑤ - colla poliuretanica o MS polimero

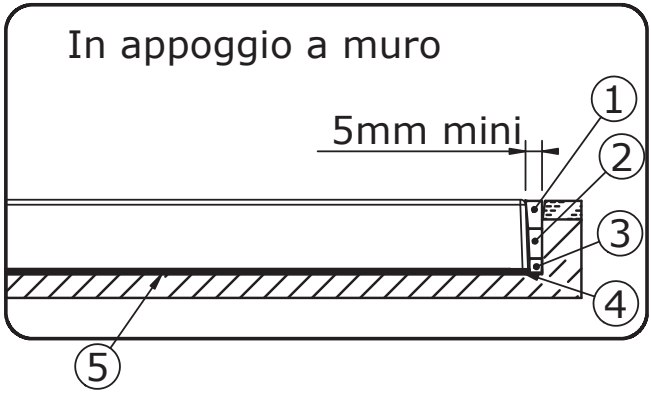
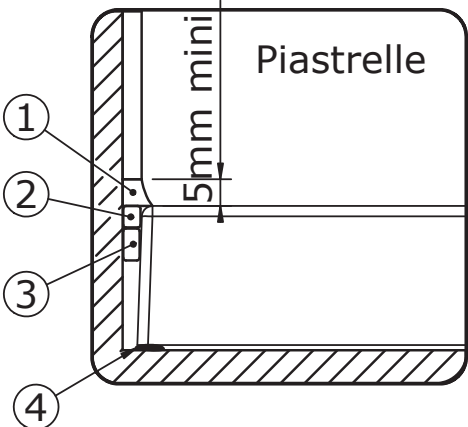



Durante la posa proteggere il piatto da graffi, colpi, attrezzi, bruciature ...



Il montaggio di una valvola di sicurezza è richiesto per un uso ottimale se un'altra utenza sono collegate allo stesso scarico.

Non utilizzare acido cloridrico o forti sgrassatori

Posa diretta al suolo

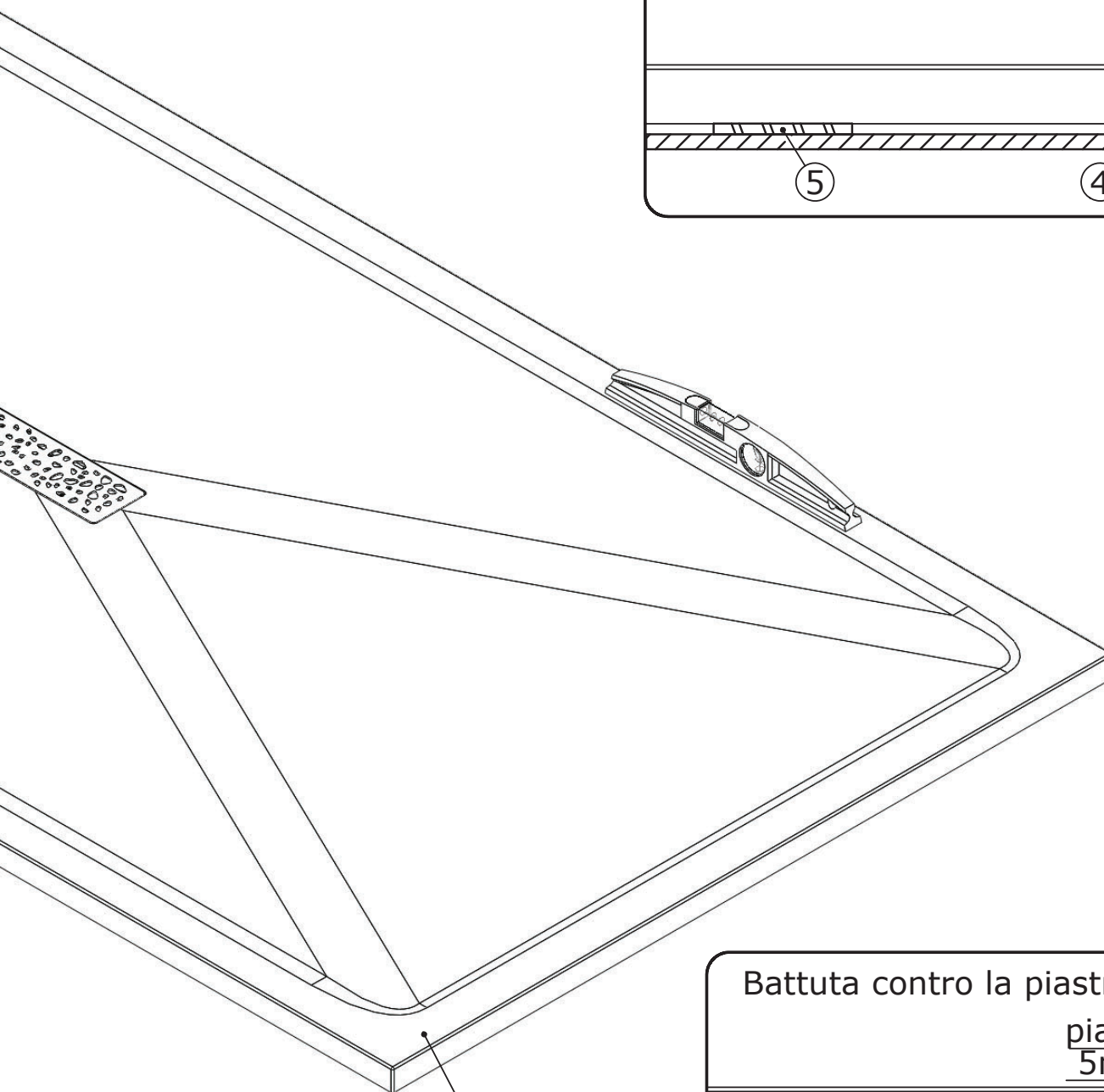
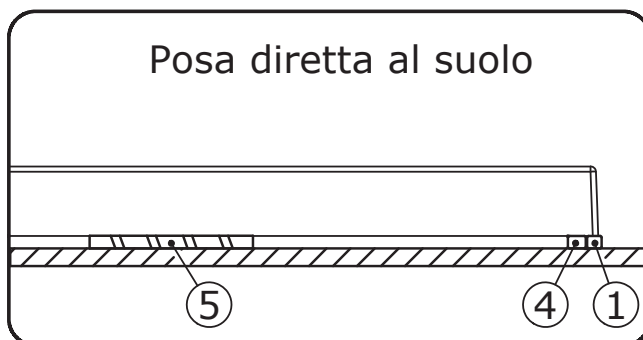

Suolo robusto e non umido

Battuta contro la piastrella

piastrella
5mm

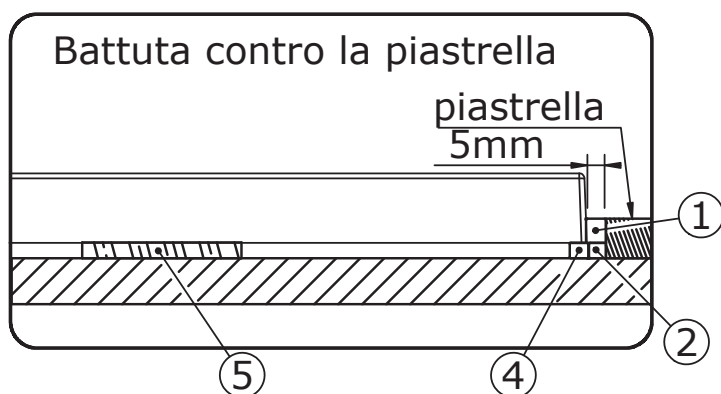

TIPI DI INSTALLAZIONE

KINEMOON STYLE

QUADRATO

1. Montato su piedini regolabili con rivestimento in piastrelle

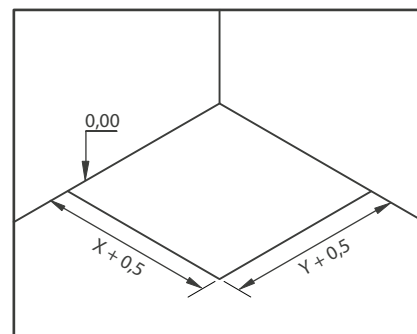
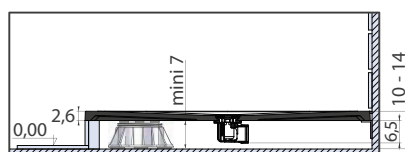

Predisposizione impianto

2. Installato in appoggio a pavimento

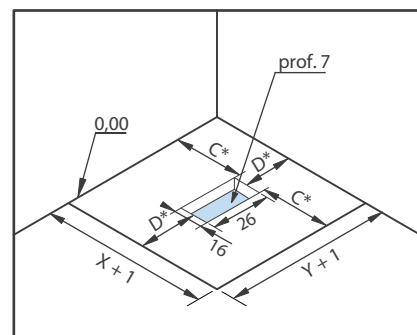
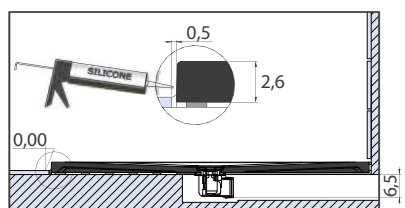
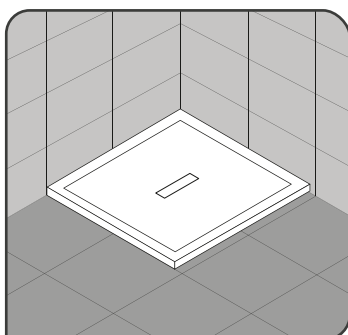

Predisposizione impianto

3. Incassato e posizionato su piedini regolabili

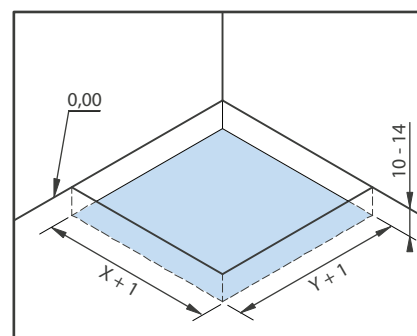
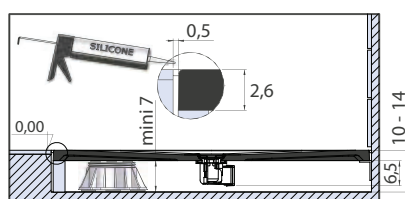

Predisposizione impianto

4. Installato a filo pavimento

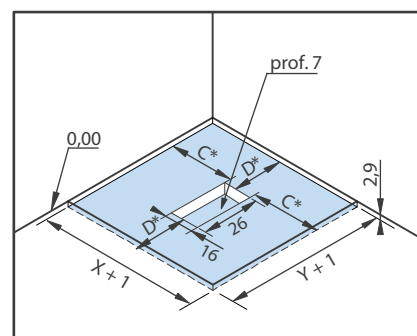
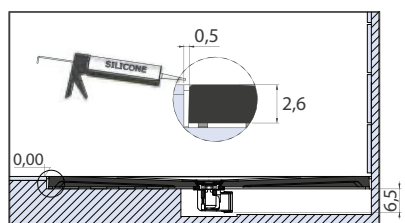
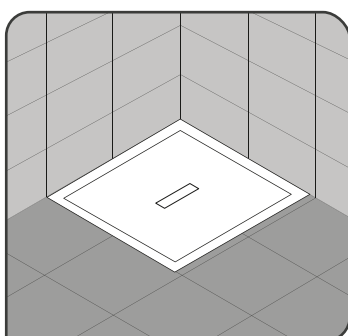

Predisposizione impianto

TIPI DI INSTALLAZIONE

KINEMOON STYLE RETTANGOLARE

1. Montato su piedini regolabili con rivestimento in piastrelle

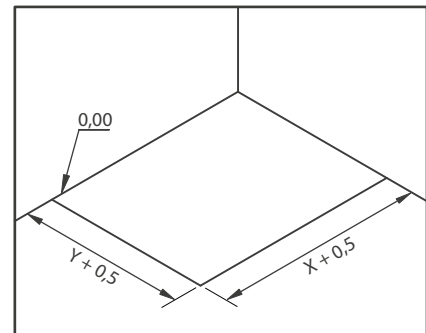
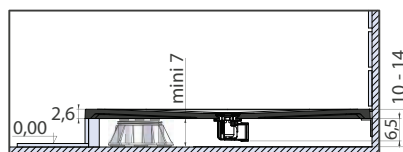

Predisposizione impianto

2. Installato in appoggio a pavimento

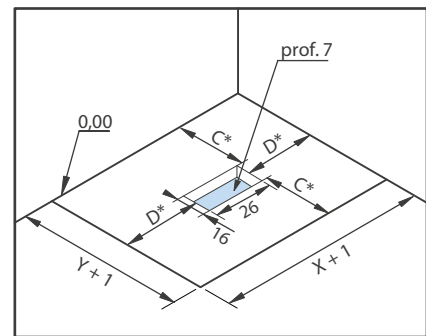
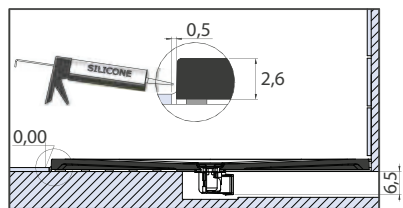
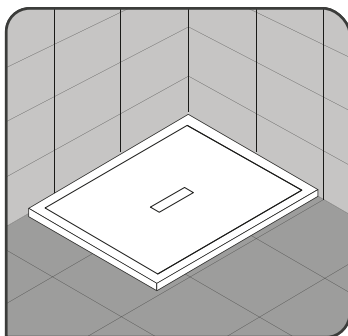

Predisposizione impianto

3. Incassato e posizionato su piedini regolabili

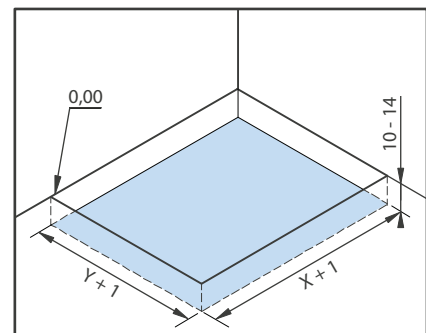
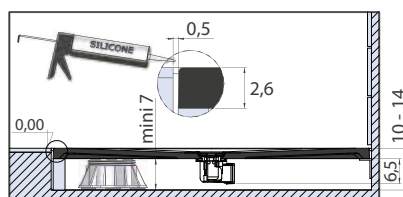

Predisposizione impianto

4. Installato a filo pavimento

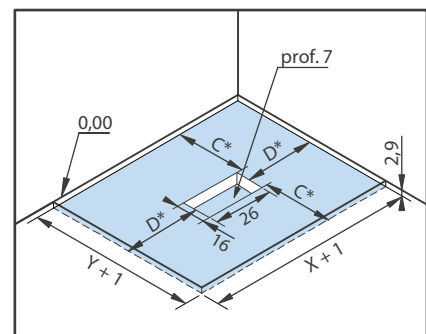
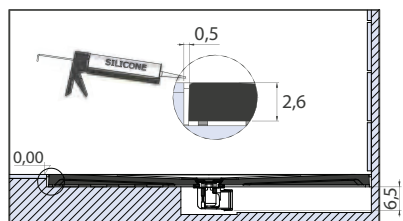
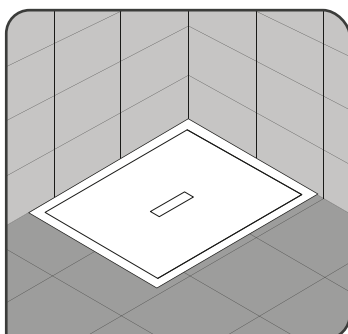

Predisposizione impianto

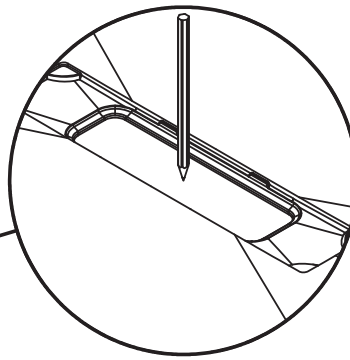
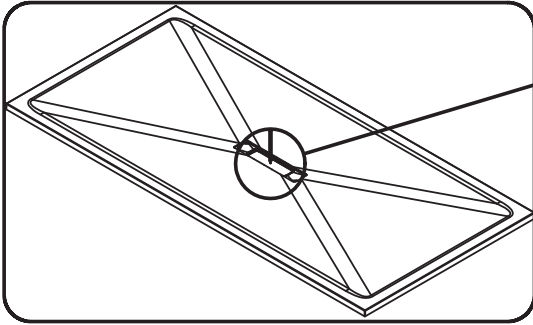

Markeer de positie van de afvoer en
situeer de afvoer en de douchebak
op de gewenste plaats

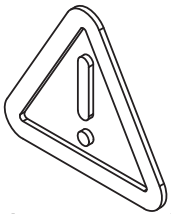
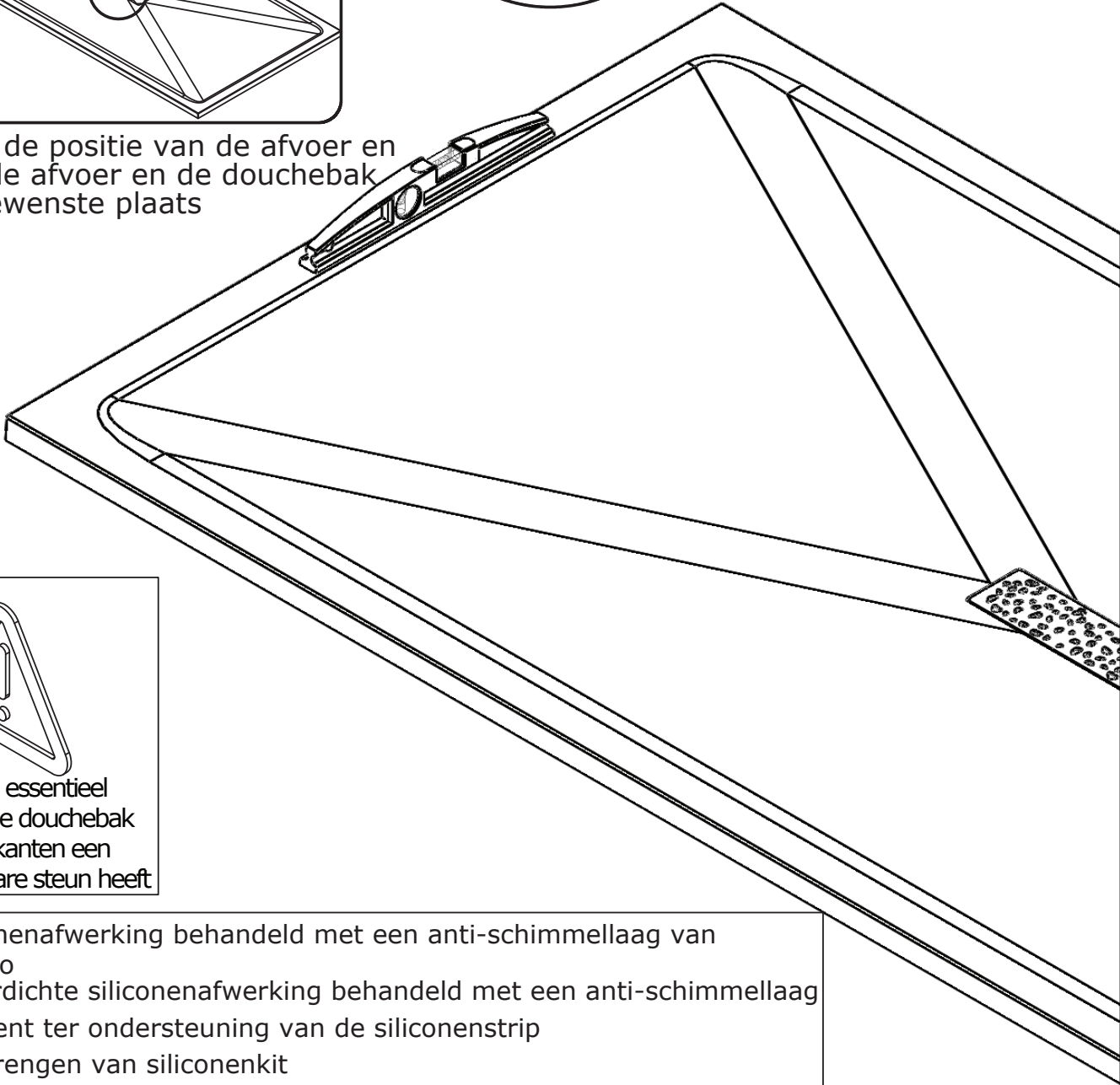

Het is van essentieel
belang dat de douchebak
aan de zijkanten een
ondoordringbare steun heeft

- ① - siliconenafwerking behandeld met een anti-schimmellaag van 5mm mino
- ② - waterdichte siliconenafwerking behandeld met een anti-schimmellaag
- ③ - element ter ondersteuning van de siliconenstrip
- ④ - aanbrengen van siliconenkit
- ⑤ - polyurethaan lijm of MS ployleer

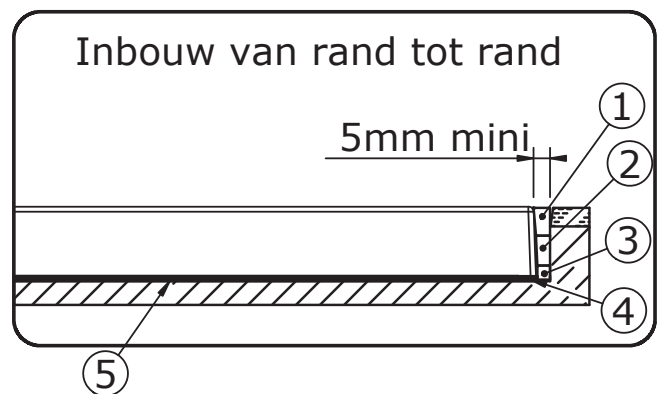
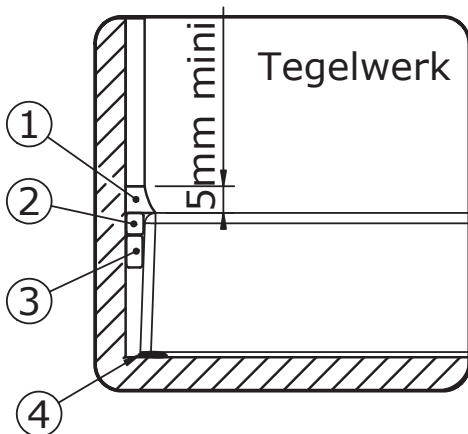



Bescherm de douchebak tijdens de werkzaamheden tegen brandplekken, schokken en beschadigingen door krassen etc...



De Montage van een afdichtingsklep/ventiel is noodzakelijk voor optimaal gebruik indien men een ander sanitair product wil aansluiten op dezelfde afvoer.

Geen chloorhoudende producten en ontvetters gebruiken!

Plaatsing direct op de vloer

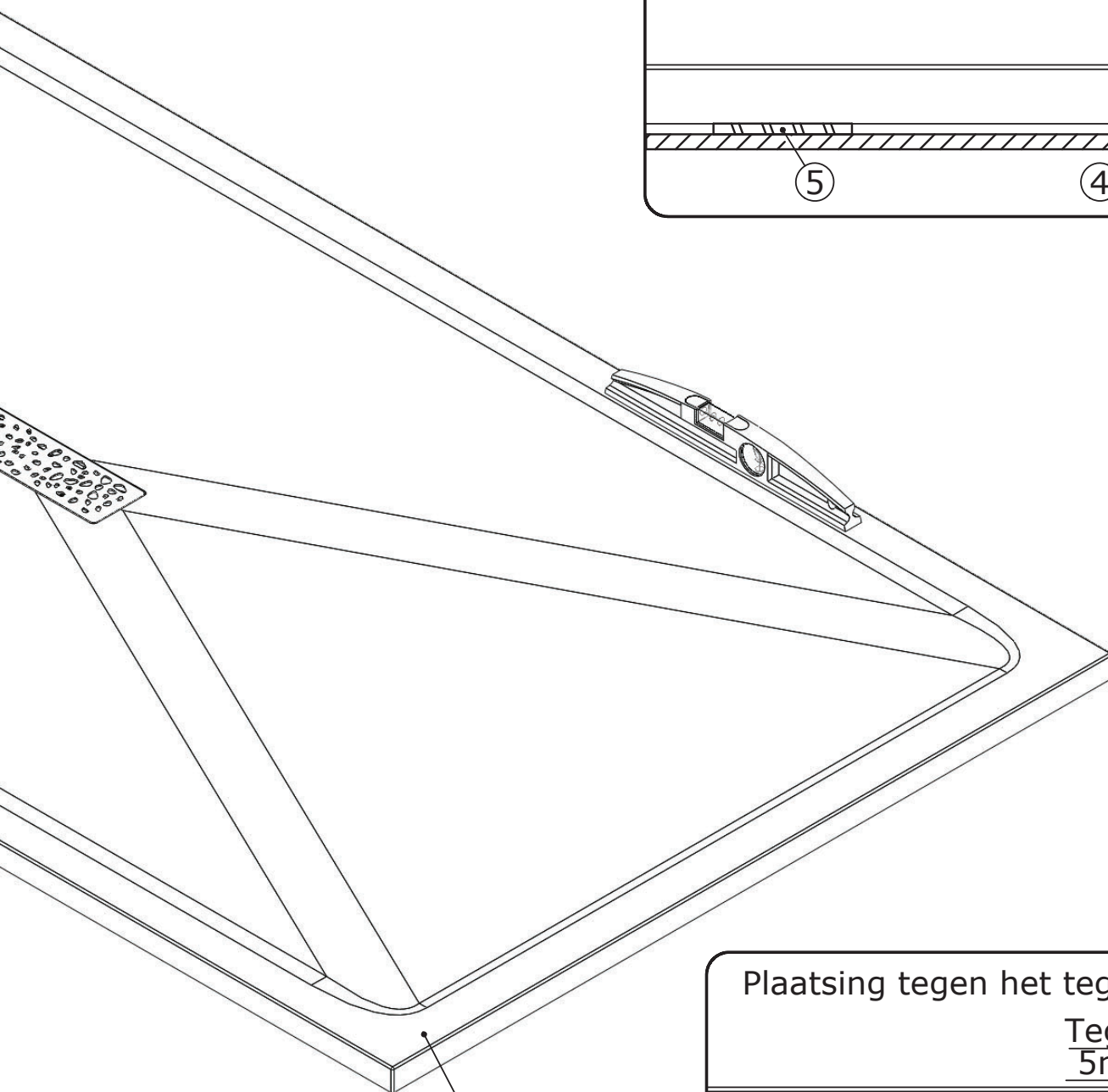
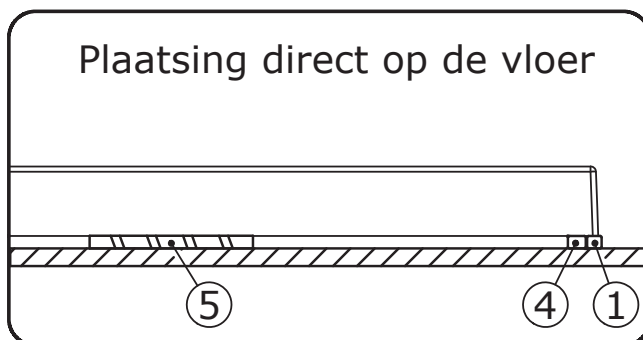

Plaatsing tegen het tegelwerk

Tegelwerk
5mm

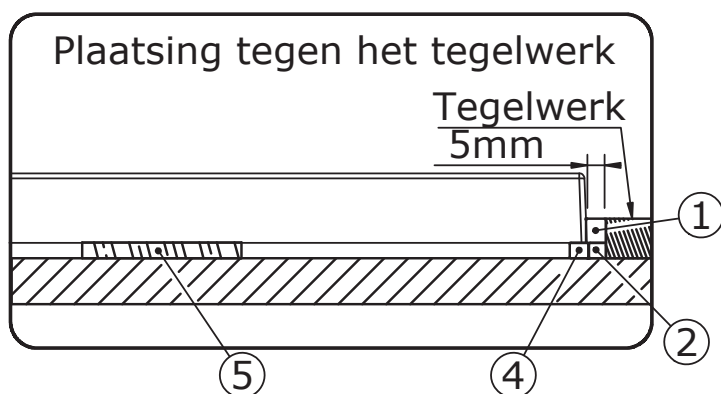

Vlakke niet-vochtige vloer is essentieel

INSTALLATIEMOGELIJKHEDEN

KINEMOON STYLE VIERKANT

1. Geïnstalleerd op in hoogte verstelbare poten en afgewerkt met tegels

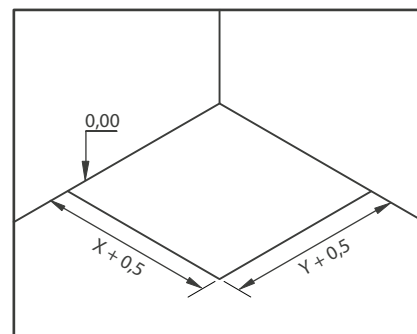
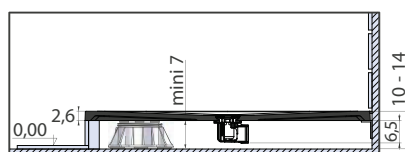

Vorbereitung montage

2. Geïnstalleerd half verzonken tegen de tegels

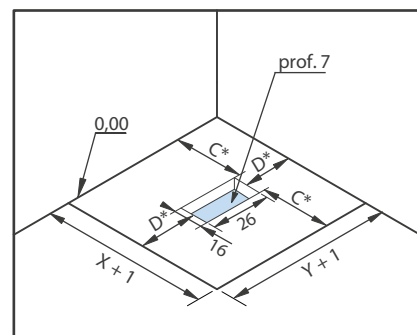
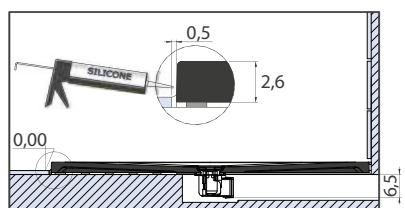
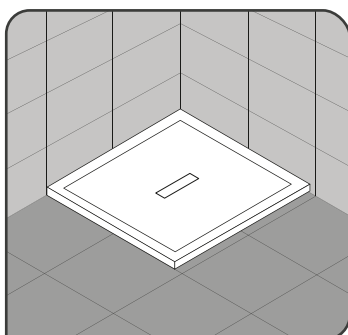

Vorbereitung montage

3. Ingebouwd met in hoogte verstelbare poten

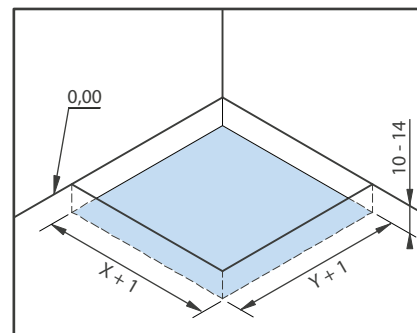
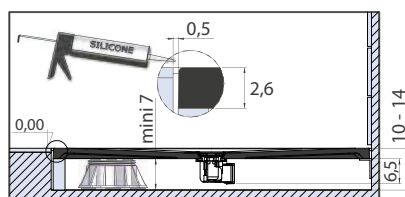

Vorbereitung montage

4. Ingebouwd zonder in hoogte verstelbare poten

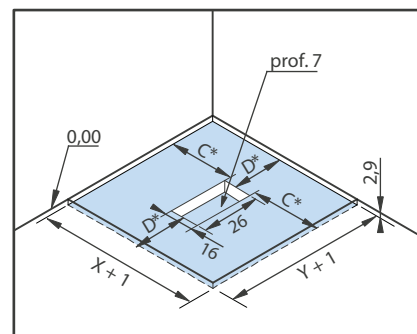
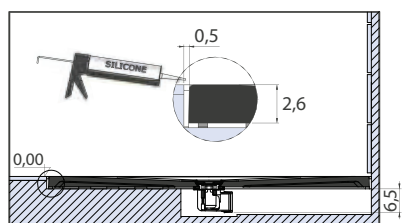
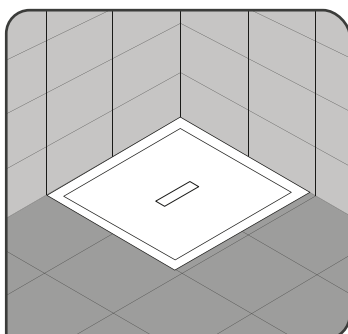

Vorbereitung montage

INSTALLATIEMOGELIJKHEDEN

KINEMOON STYLE RECHTHOEKIG

1. Geïnstalleerd op in hoogte verstelbare poten en afgewerkt met tegels

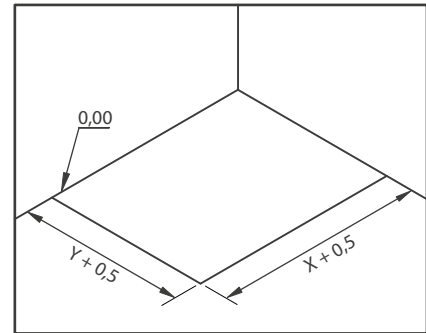
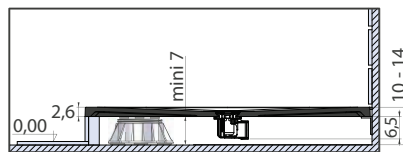

Vorbereitung montage

2. Geïnstalleerd half verzonken tegen de tegels

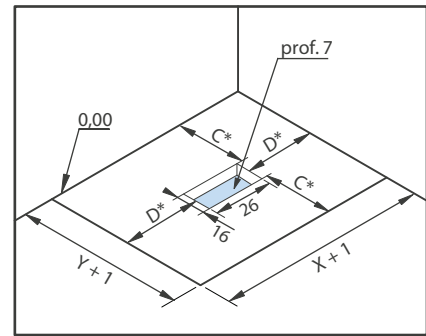
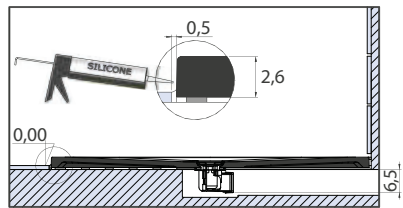
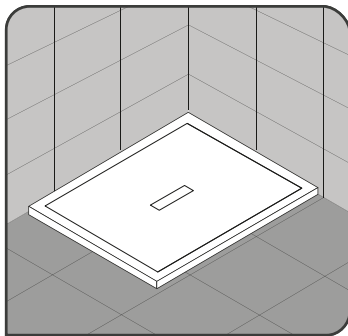

Vorbereitung montage

3. Ingebouwd met in hoogte verstelbare poten

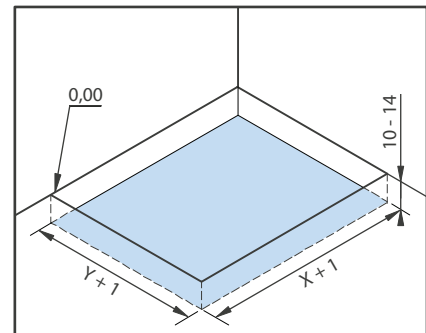
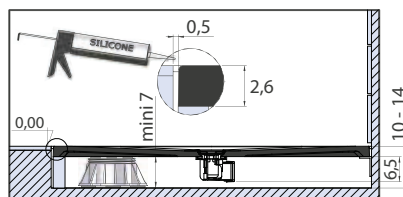

Vorbereitung montage

4. Ingebouwd zonder in hoogte verstelbare poten

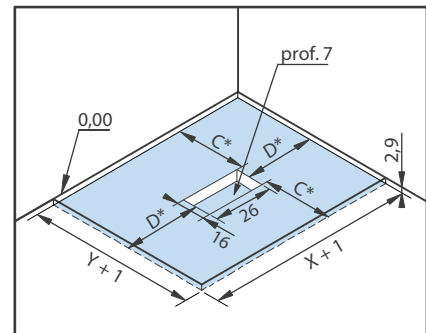
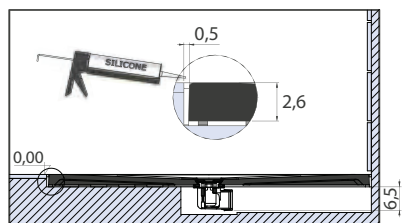
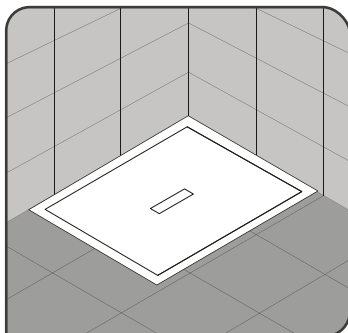

Vorbereitung montage

D

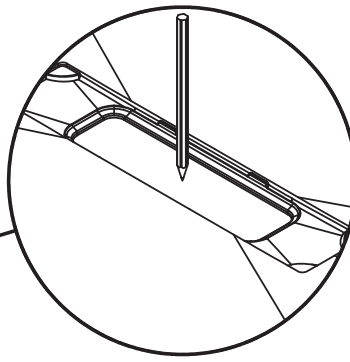
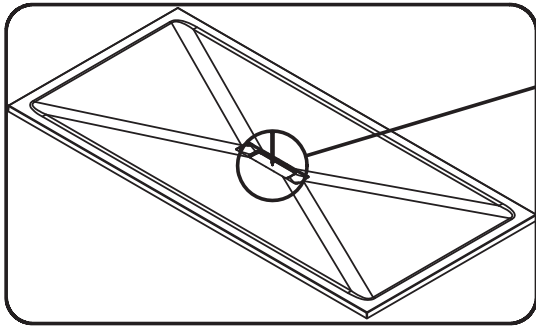

Position für den Ablauf anzeichnen und vormontieren.

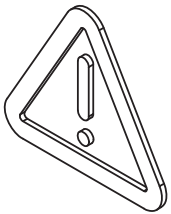
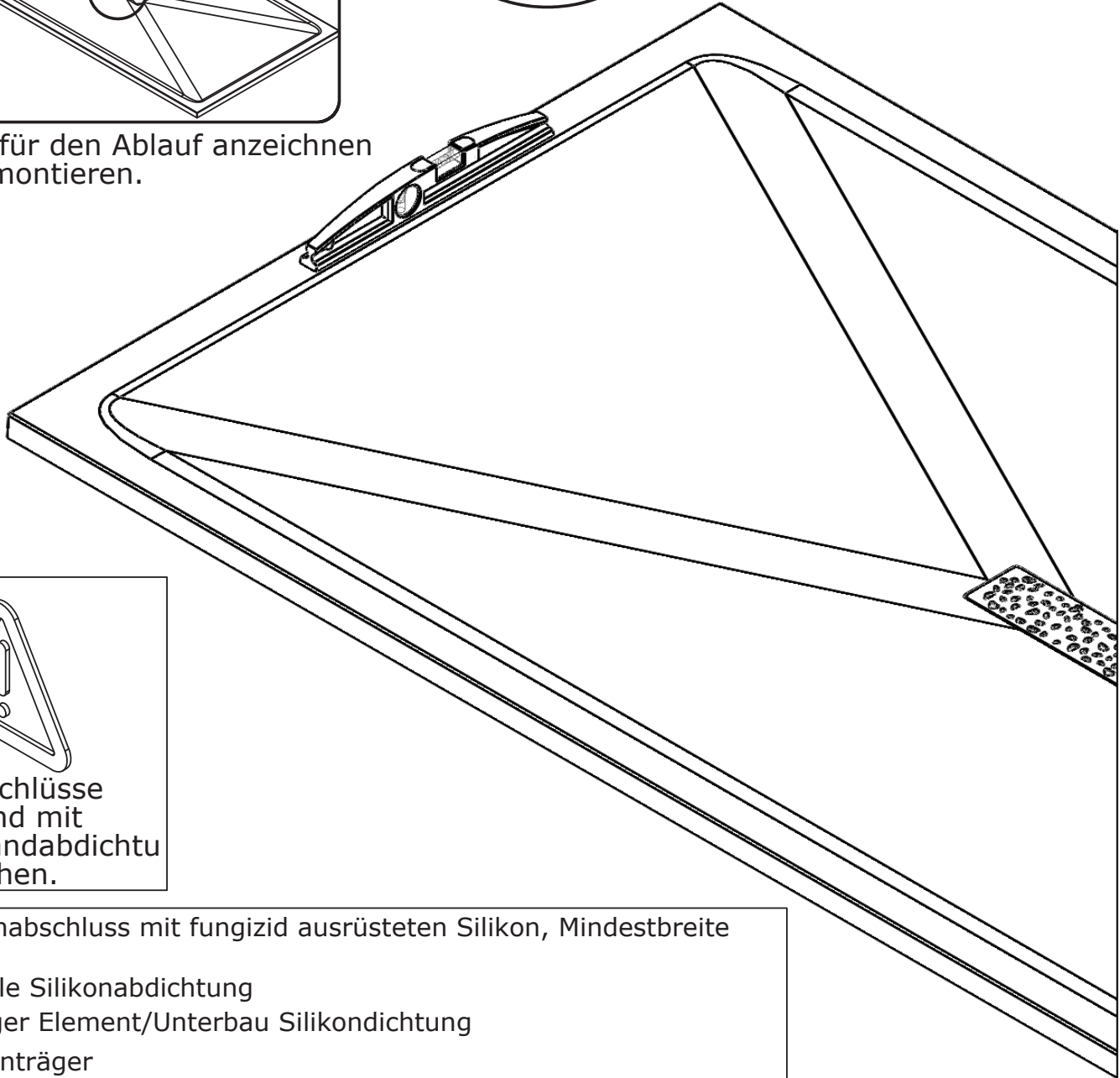

Wandanschlüsse umlaufend mit Wannensrandabdichtung zu versehen.

- ① - Fugenabschluss mit fungizid ausgerüsteten Silikon, Mindestbreite von 5mm
- ② - flexible Silikonabdichtung
- ③ - Träger Element/Unterbau Silikondichtung
- ④ - Silikonträger
- ⑤ - Polyurethan-Klebstoff oder MS-Polymer

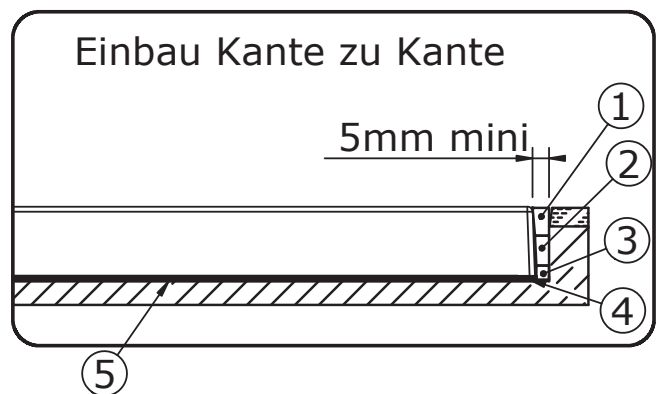
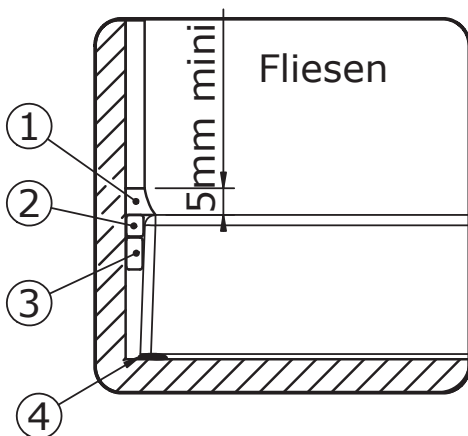



Während den Installationsarbeiten auf ausreichenden Schutz gegen aggressive Mittel achten: Verbrennungen, Stöße, Kratzer oder Abbeizmittel...



Montage eines Unterdruckventils wird benötigt, wenn eine andere Vorrichtung an den gleichen Ablauf angeschlossen ist.

Verwenden Sie keine säurehaltigen oder andere aggressive Entfetter.

freie Aufstellung auf
Fertigfußboden

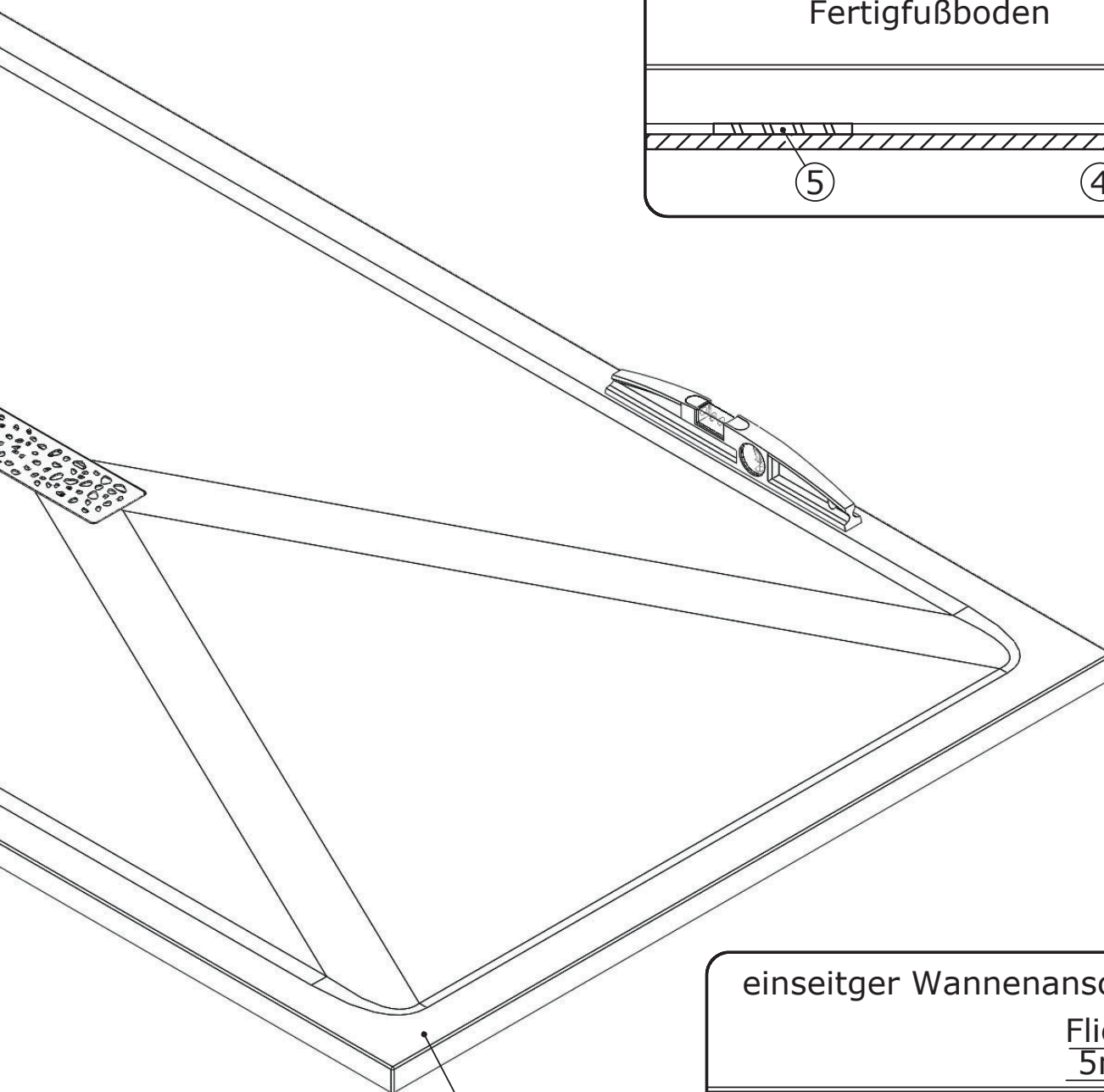

einseitiger Wannenanschluß

Fliesen
5mm

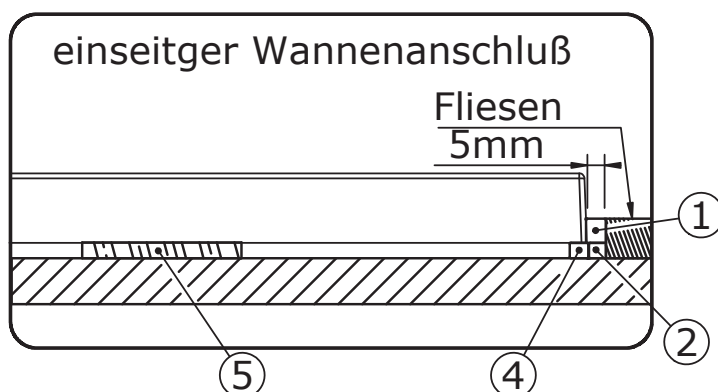

Auf festen, planen und nicht feuchten Boden achten.

INSTALLATIONSARTEN

KINEMOON STYLE QUADRAT

1. Montage auf Fertigfußboden mit Wannenfüßen und Fliesensockel

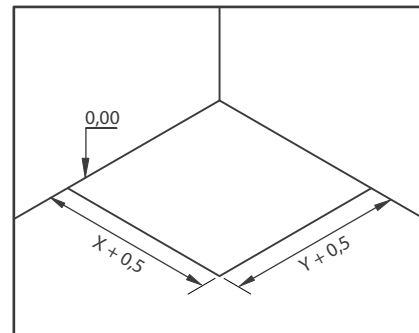
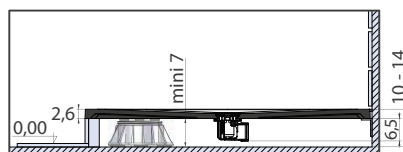
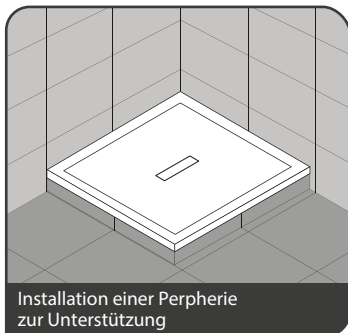

Montagevorbereitung Fertigfußboden mit Wannenfüße

2. Wird im Widerlager gegen die Fliese montiert

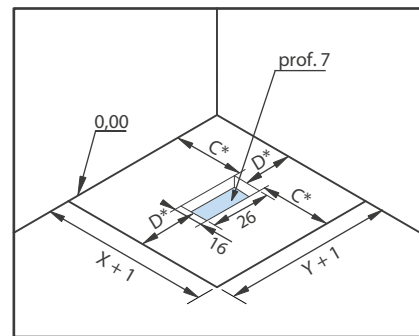
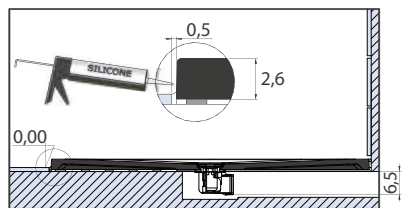
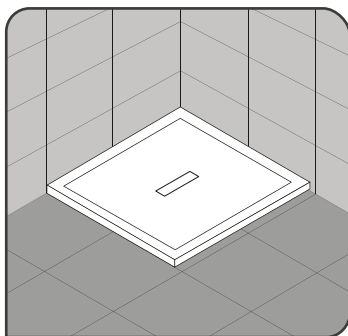

Montagevorbereitung Fertigfußboden mit Wannenfüße

3. Bodengleiche Montage mit Wannenfüße

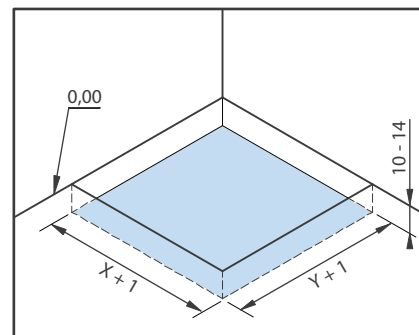
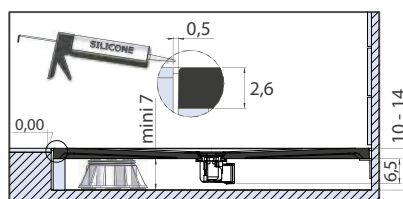

Montagevorbereitung Fertigfußboden mit Wannenfüße

4. Bodengleiche Montage ohne Wannenfüße

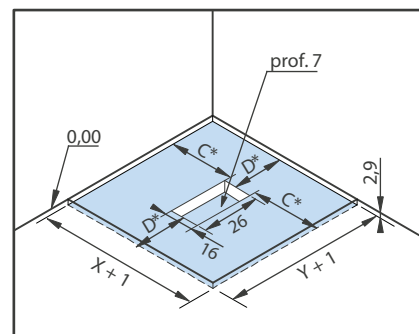
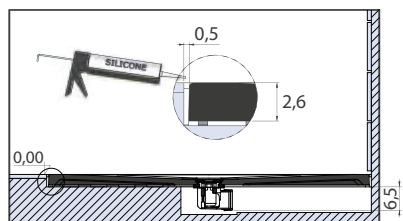
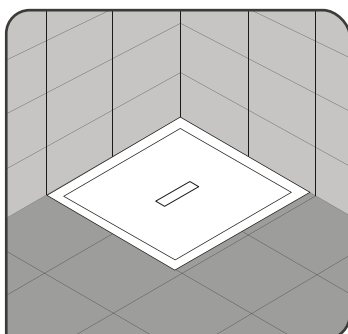

Montagevorbereitung Fertigfußboden mit Wannenfüße

INSTALLATIONSARTEN

KINEMOON STYLE RECHTECKIG

1. Montage auf Fertigfußboden mit Wannenfüßen und Fliesensockel

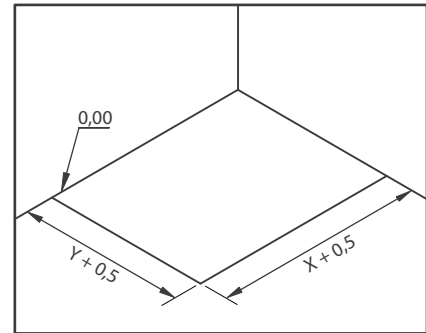
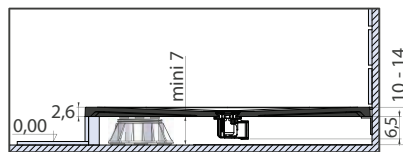

Montagevorbereitung Fertigfußboden mit Wannenfüße

2. Wird im Widerlager gegen die Fliese montiert

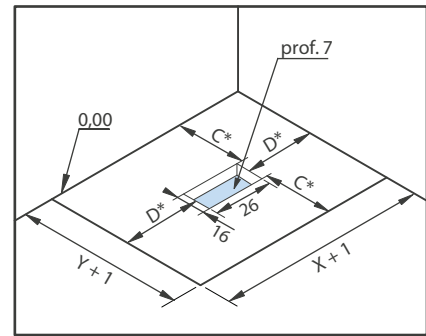
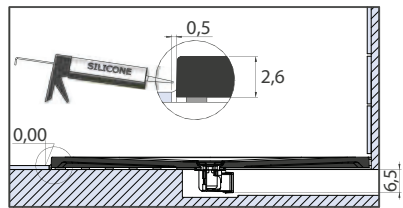
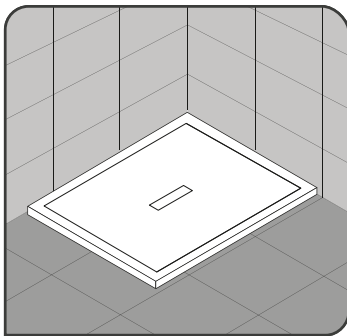

Montagevorbereitung Fertigfußboden mit Wannenfüße

3. Bodengleiche Montage mit Wannenfüße

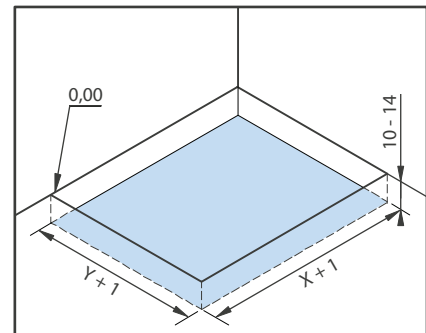
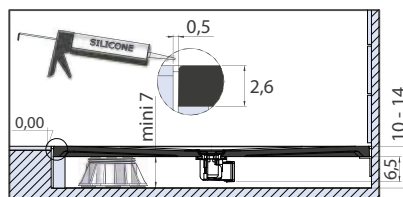

Montagevorbereitung Fertigfußboden mit Wannenfüße

4. Bodengleiche Montage ohne Wannenfüße

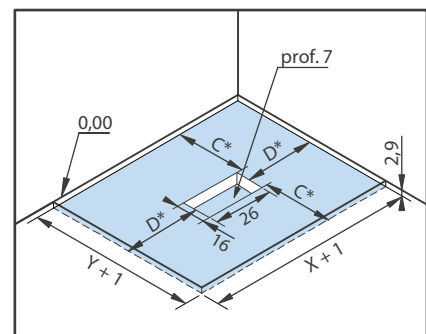
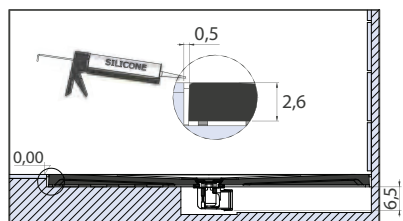
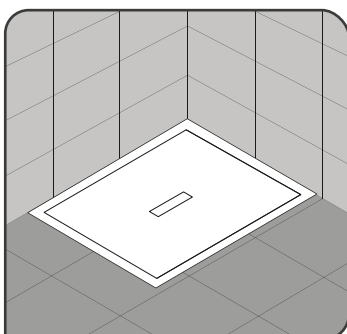

Montagevorbereitung Fertigfußboden mit Wannenfüße

- F Mise en place des plots de colle polyuréthane ou MS polymère
- GB Loading the plots glue polyurethane or MS polymer
- E Ubicacion de los puntos de pegamento poliuretano o polimero MS
- I Posizione dei punti di colla poliuretano o MS polimero
- NL Breng de polyurethaan lijm of MS polymeer aan op de juiste plaats
- D Bringen Sie den Polyurethan-/MS-Polymere-Kleber auf

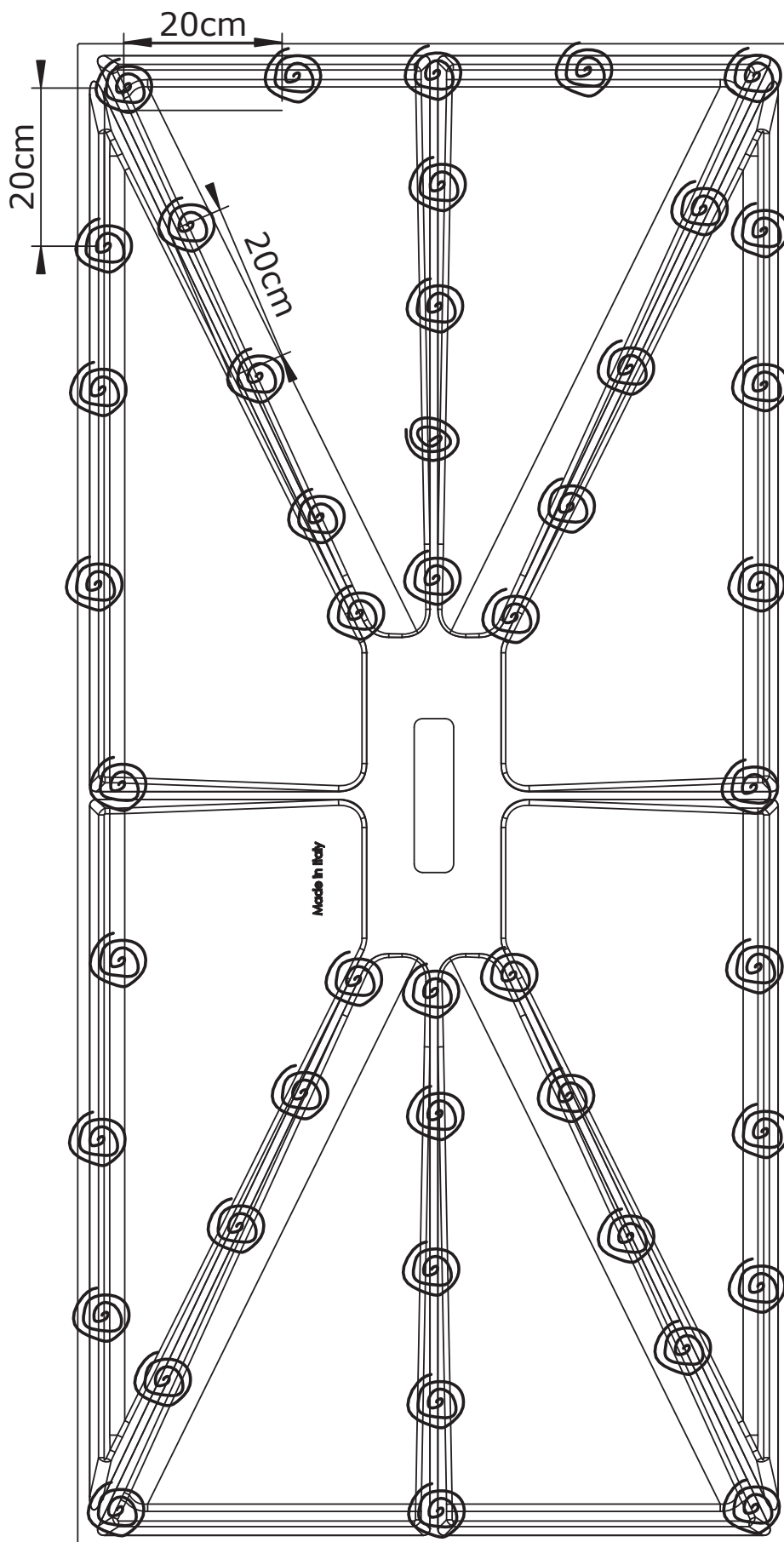

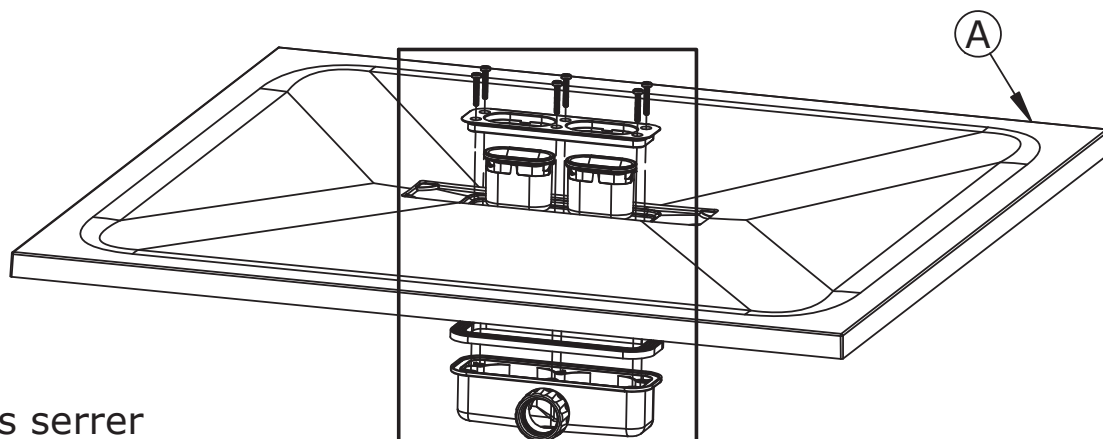

- F Ne pas serrer
- GB Do not overtighten
- E No apretar
- I Non stringere
- NL Niet vast schroeven
- D Nicht festziehen

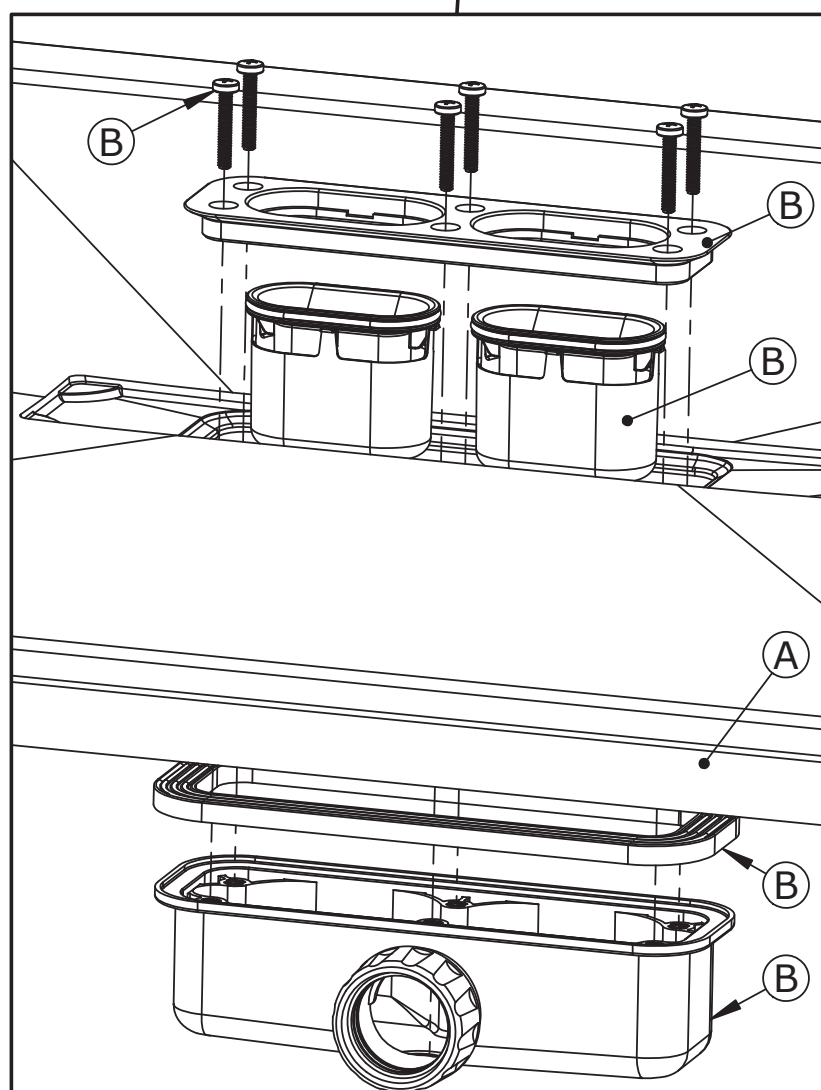



24h

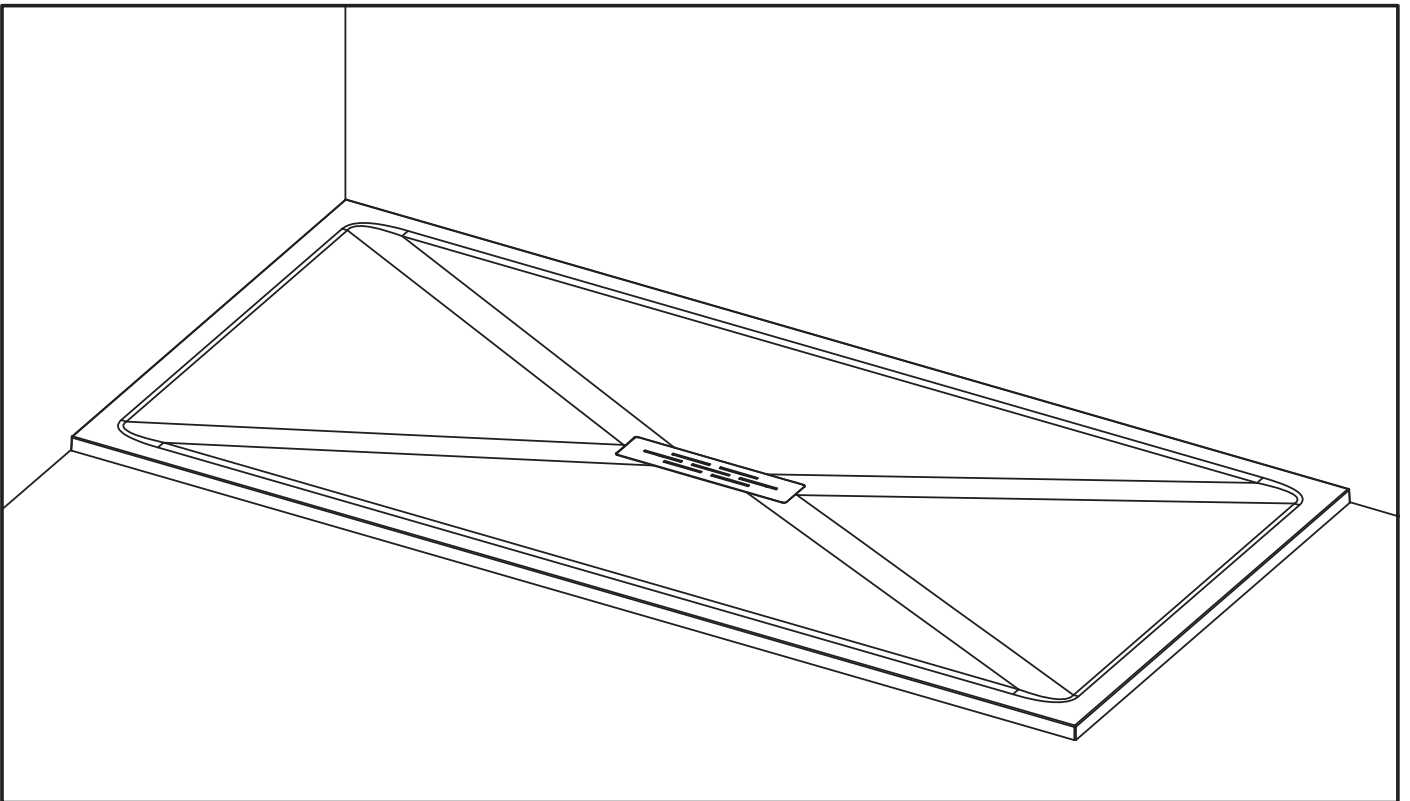



AQUAPRODUCTION, Site industriel,
F - 44680 Chaumes-en-Retz

20

EN 14527 - CL2

Aptitude au nettoyage : satisfaisant

Durabilité : satisfaisant



SAV
SERVICE HELPLINES
ASSISTENZA POST-VENDITA
SERVICIO POSTVENTA

FRANCE

02 40 21 29 45

UK

020 8842 0033

IRELAND

04697 33102

DEUTSCHLAND

+49 (0) 6074 / 30928 0

ITALIA

(0382) 6181

OSTEREICH

+43 1 710 60 70

SCHWEIZ

(01) 748 17 44

ESPANA

93 544 60 76

NEDERLAND

+31 475 487 100

BELGIË

+31 475 487 100

BELGIQUE

+31 475 487 100

РОССИЯ

963 19 40, 773 67 22